

MS08 - MSE08

HYDRAULIC MOTORS

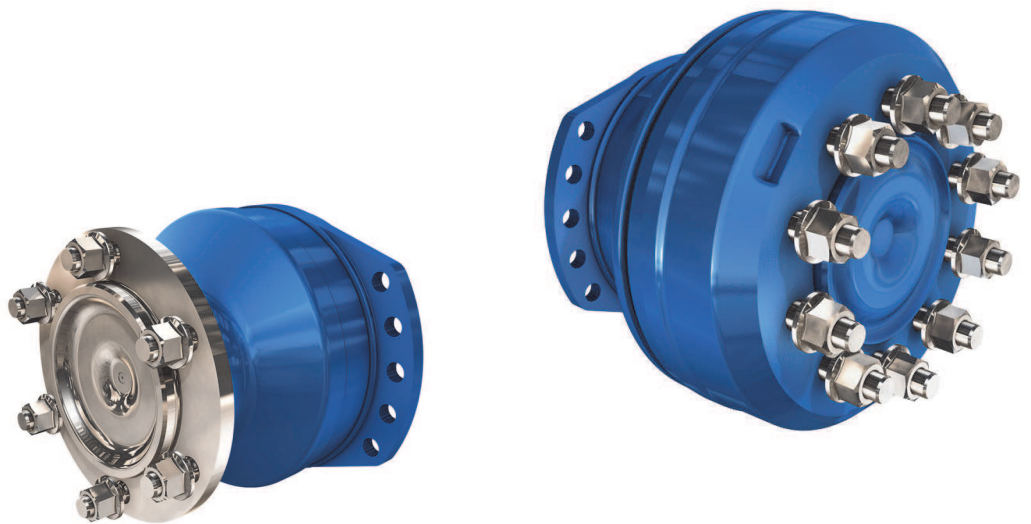

T E C H N I C A L C A T A L O G

PH
POCLAIN HYDRAULICS
PH

◀ **Poclain** Driving Values for the Future



CHARACTERISTICS

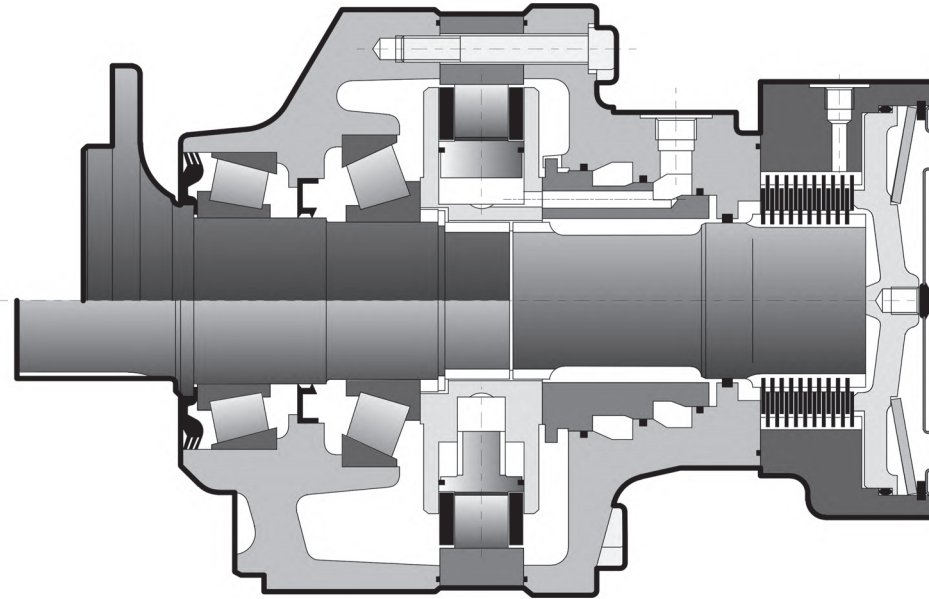

Motor inertia = 0.05 kg.m²
 Noise emissions = 60 dBA

	C	Displacement		Theoretical torque		Max. power			Max. speed		Max. pressure
		①	②	①		①	②	②	①	②	
		cm ³ /tr [cu.in./rev.]	cm ³ /tr [cu.in./rev.]	at 100 bar [lb.ft]	at 1000 PSI [lb.ft]	at 100 bar [kW [HP]]	preferred [kW [HP]]	non-preferred [kW [HP]]	tr/min [RPM]	tr/min [RPM]	
Cams with equal lobes	MS08	6	467 [28.5]	234 [14.2]	743 [378]	41 [55]	27 [36]	21 [28]	170	210	450 [6 527]
		8	627 [38.2]	314 [19.1]	997 [507]						
		9	702 [42.8]	351 [21.4]	1116 [568]						
		0	780 [47.6]	390 [23.8]	1240 [631]						
		1	857 [52.3]	429 [26.1]	1363 [693]						
		2	934 [57.0]	467 [28.5]	1485 [755]						
		0	1 043 [63.6]	522 [31.8]	1658 [843]						
Cams with unequal lobes	MSE08	1	1 146 [69.9]	573 [34.9]	1822 [927]	41 [55]	27 [36]	21 [28]	110	130	400 [5 802]
		2	1 248 [76.1]	624 [38.1]	1984 [1 009]						
		Q	623 [38.0]	390 [23.8] / 233 [14.2]	991 [504]						
Cams with unequal lobes	MS08	D	700 [42.7]	467 [28.5] / 233 [14.2]	1113 [566]	41 [55]	27 [36]	21 [28]	140	140	450 [6 527]
		A	780 [47.6]	467 [28.5] / 313 [19.1]	1240 [631]						
		Q	833 [50.8]	522 [31.8] / 312 [19.0]	1324 [674]						
Cams with unequal lobes	MSE08	D	936 [57.1]	624 [38.1] / 312 [19.0]	1488 [757]	41 [55]	27 [36]	21 [28]	105	125	400 [5 802]
		A	1 043 [63.6]	624 [38.1] / 418 [25.5]	1658 [843]						

- ① First displacement
- ② Second displacement

* See option "M" for higher speed.

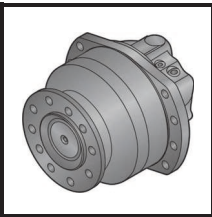
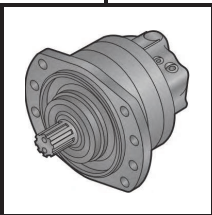
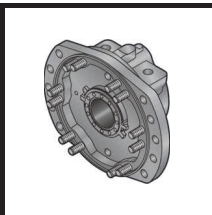
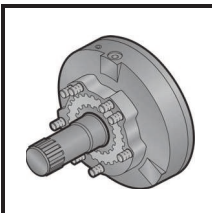
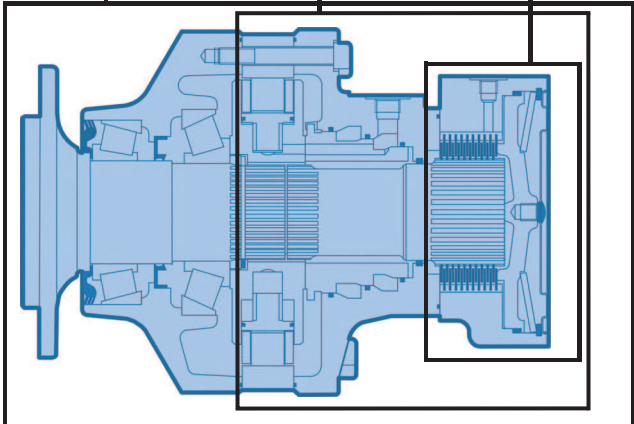

CONTENT

	MODULARITY	4	Modularity and Model code
	MODEL CODE	6	
	WHEEL MOTOR	8	Wheel motor
	Dimensions for standard (1110) 1-displacement motor	8	
	Dimensions for standard (1110) 2-displacement motor	9	
	Dimensions for standard (1110) Twin-Lock™	9	
	Support types	10	
	Load curves	11	
	Support types (continued)	12	
	SHAFT MOTOR	15	Shaft motor
	Dimensions for standard (2A50) 1-displacement motor	15	
	Dimensions for standard (2A50) 2-displacement motor	15	
	Support types	16	
	Radial load and service life of bearings curves	17	
	VALVING SYSTEMS AND HYDROBASES	19	Valving systems and hydrobases
	Dimensions for 1-displacement valving	19	
	Cylinder block splines	19	
	Dimensions for other valving systems	20	
	Exchange	22	
	Chassis mountings	22	
	Hydraulic connections	23	
	Efficiency	24	
	BRAKES	25	Brake
	Rear brake	25	
	Drum brake (270 x 60 or 315 x 80)	26	
	OPTIONS	27	Options



MODUL

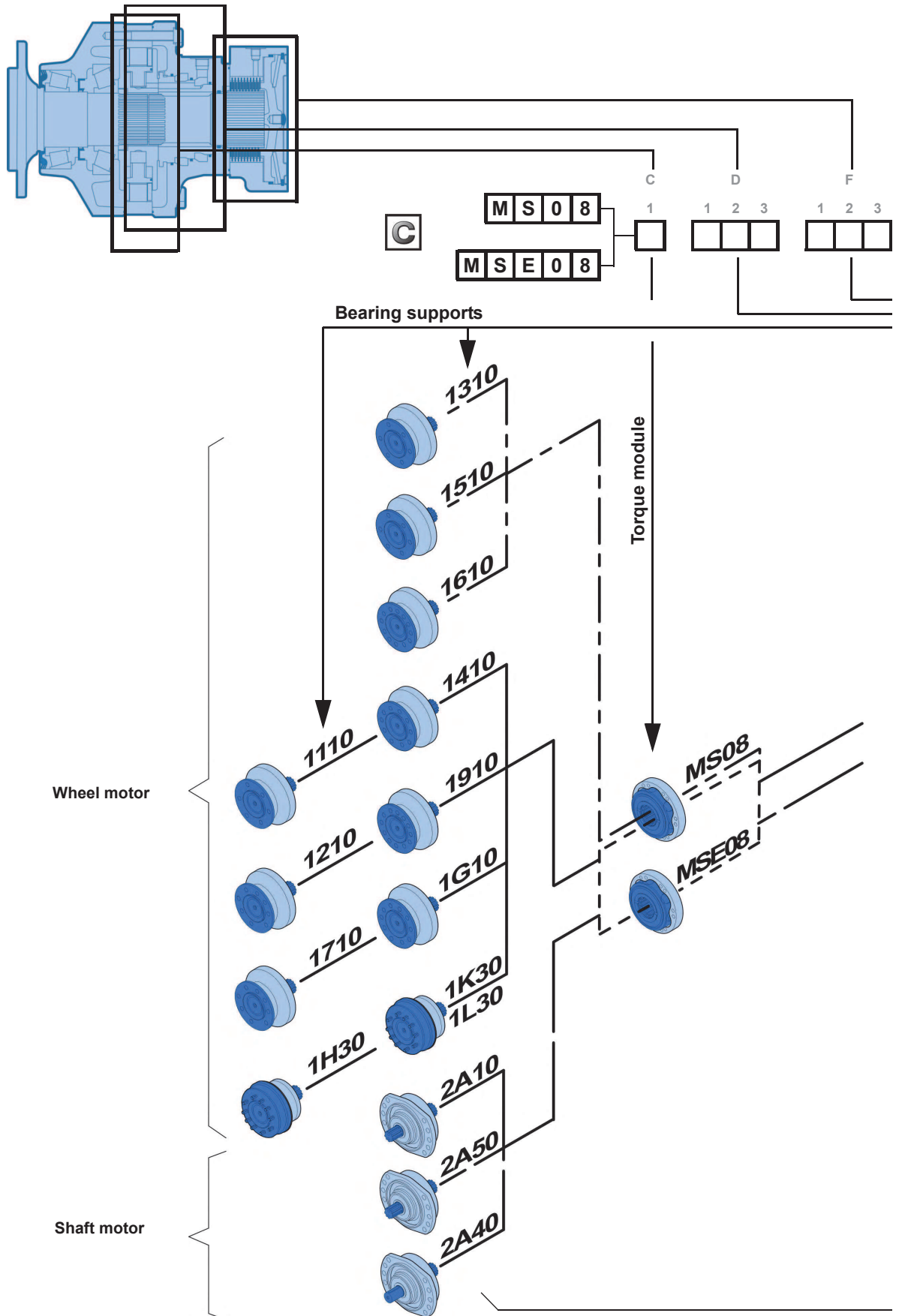



ARITY

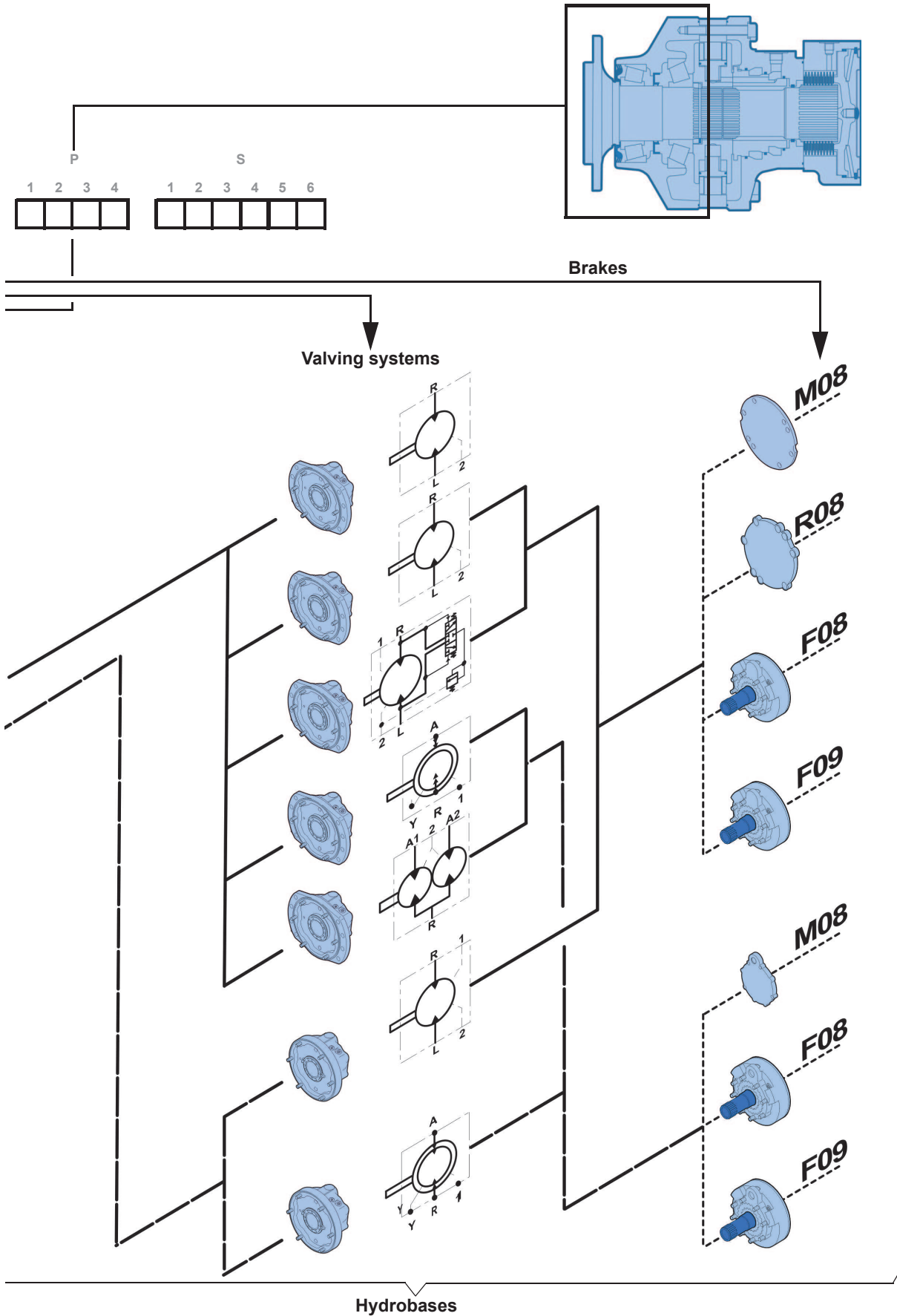

Modularity and Model code

Wheel motor

Shaft motor

Valving systems and hydrobases

Brake

Options



MODEL

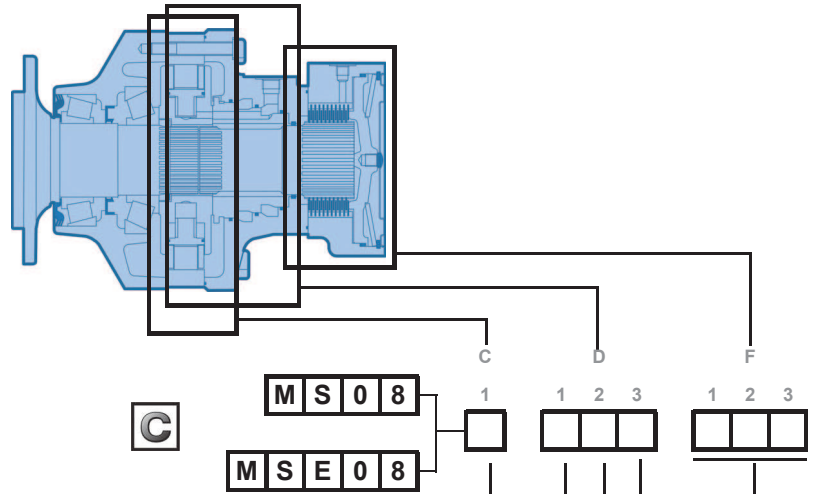

		①		②	
		cm ³ /tr [cu.in/rev.]	cm ³ /tr [cu.in/rev.]	cm ³ /tr [cu.in/rev.]	cm ³ /tr [cu.in/rev.]
Cams with equal lobes	MS08	6	467 [28.5]	234 [14.2]	
		8	627 [38.2]	314 [19.1]	
		9	702 [42.8]	351 [21.4]	
		0	780 [47.6]	390 [23.8]	
		1	857 [52.3]	429 [26.1]	
		2	934 [57.0]	467 [28.5]	
Cams with unequal lobes	MS08	Q	623 [38.0]	390 [23.8] 233 [14.2]	
		D	700 [42.7]	467 [28.5] 233 [14.2]	
		A	780 [47.6]	467 [28.5] 313 [19.1]	
Cams with unequal lobes	MSE08	Q	833 [50.8]	522 [31.8] 312 [19.0]	
		D	936 [57.1]	624 [38.1] 312 [19.0]	
		A	1 043 [63.6]	624 [38.1] 418 [25.5]	

- ① First displacement
- ② Second displacement

1-displacement valving	1
2-displacement & Twin-Lock™ valving (Clockwise)	D Ratio 2 E Ratio <2 F Ratio >2
2-displacement & Twin-Lock™ valving (Counterclockwise)	G Ratio 2 H Ratio <2 J Ratio >2

Without mounting	1	4	D
With mounting	2	5	E

1 displacement
2 displacement

Exchange Twin-Lock™

ISO 6162 Flanges	1
ISO 11926-1 connections	1
ISO 6162 Flanges	2
ISO 1179-1 connections	2
ISO 1179-1 connection	3
ISO 9974-1 connections (M22 x 1.5)	4
ISO 9974-1 connections (M27 x 2)	5
ISO 6149-1 connection	8
ISO 11926-1 connections	A

One-piece valving cover single displacement	M 0 8
Brake	F 0 8
	F 0 9
Without brake (reinforced plate)	R 0 8



CODE

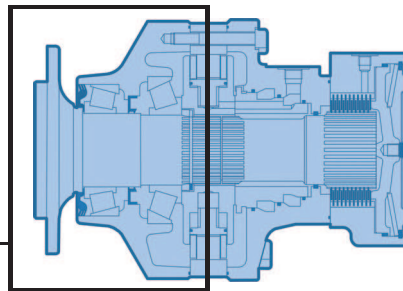

Modularity and Model code

Wheel motor

Shaft motor

Valving systems and hydrobases

Brake

Options

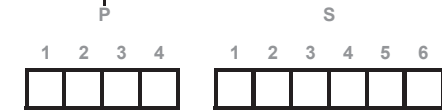

0	Without bearing support
1	Without mounting
2	Lug mounting

Without shaft	0
6 x Ø20 on Ø205	1
8 x Ø22 on Ø203.2	2
6 x Ø20 on Ø205	3
6 x Ø18 on Ø152.4	5
12 x M12 on Ø205	6
8 x Ø22 on Ø275	7
12 x Ø14 on Ø165	9

Support without drum brake	G
Drum brake (270 x 60)	Mineral K DOT L
Drum brake (315 x 80)	Mineral P DOT Q
For male shaft bearing support	A

Without studs	1
With studs + nuts	2
With studs	3
M threaded holes	4

Male shafts	
NF E 22141 splines	1
Cylindrical with key	4
DIN 5480 splines	5

Drum brake	
Without cable	4
Right-hand cable outlet	5 (270 x 60)
Left-hand cable outlet	6
Without cable	Q
Right-hand cable outlet	R (315 x 80)
Left-hand cable outlet	S

Without Options or Adaptations	0
Fluorinated elastomer seals	1
T4 speed sensor (without rotation direction)	2
Brake environmental cover without plug	3
Drainage (additional drain in the cover)	5
Industrial bearing support	6
Diamond™	7
Predisposition for speed sensor	8
Hollow shaft	A
Drain on the bearing support	B
Abrasive environment (mechanical seal)	C
Special paint or no paint	D
Reinforced sealing	E
Special wheel rim mounting	G
High efficiency	H
Surface heat treatment of the shaft	J
High speed	M
TD speed sensor (two phase shifted frequencies)	Q
TR speed sensor (digital rotation direction)	S



WHEEL MOTOR

Dimensions for standard (1110) 1-displacement motor

	60 kg [132 lb]	79 kg [174 lb]
	1,50 L [90 cu.in.]	1,00 L [60 cu.in.]

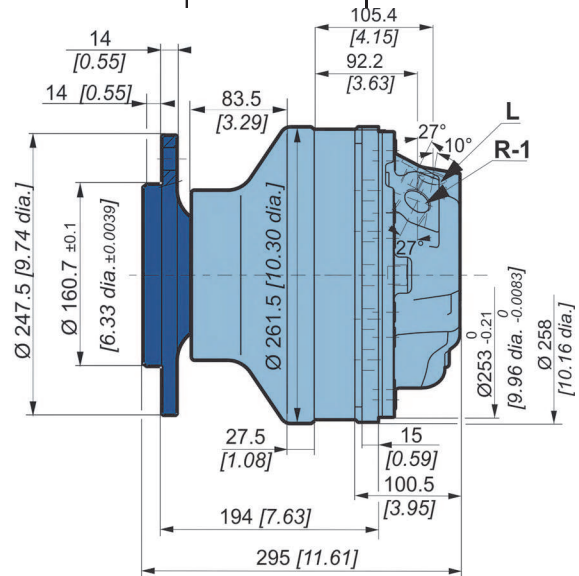
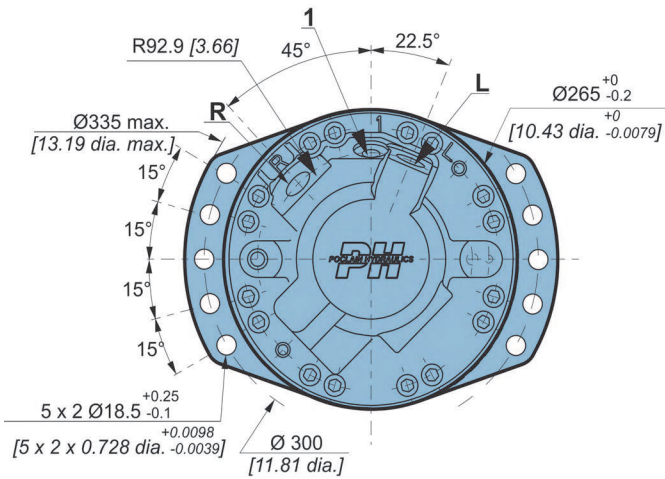
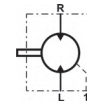

Dimensions for standard (1110) 1-displacement motor

	60 kg [132 lb]	79 kg [174 lb]
	1,50 L [90 cu.in.]	1,00 L [60 cu.in.]

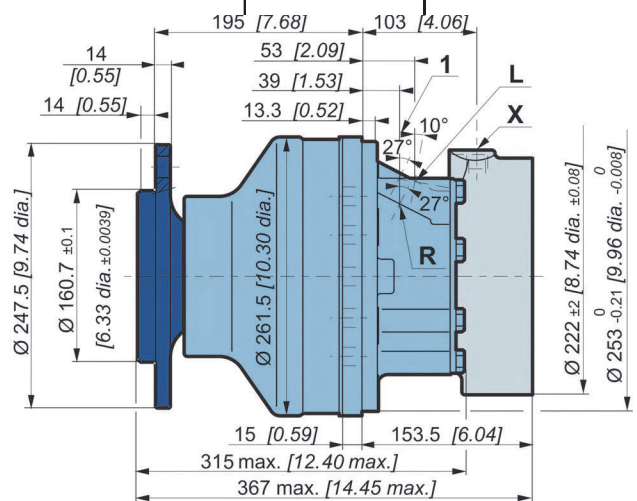
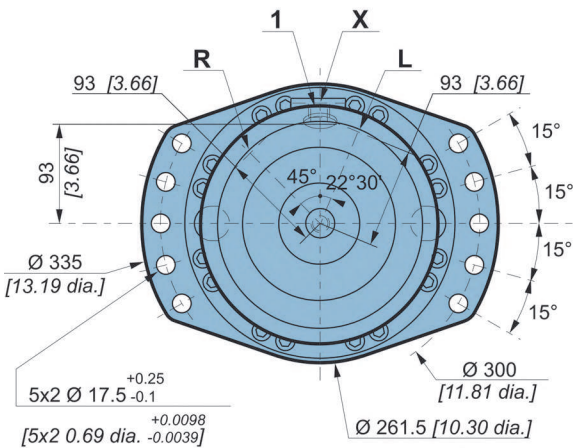
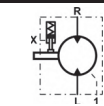
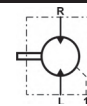



Dimensions for standard (1110) 2-displacement motor

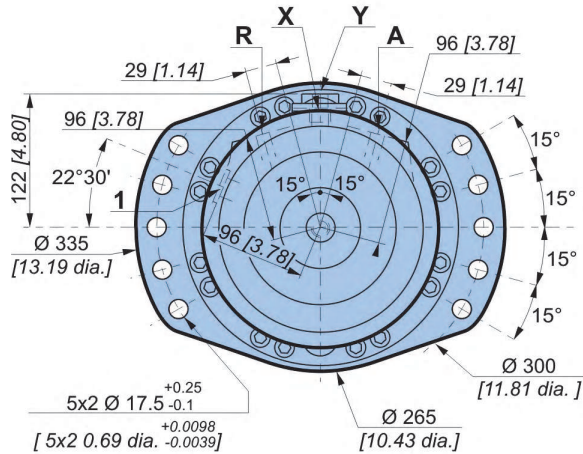

	65 kg [143 lb]	84 kg [185 lb]
	1,50 L [90 cu.in.]	1,00 L [60 cu.in.]

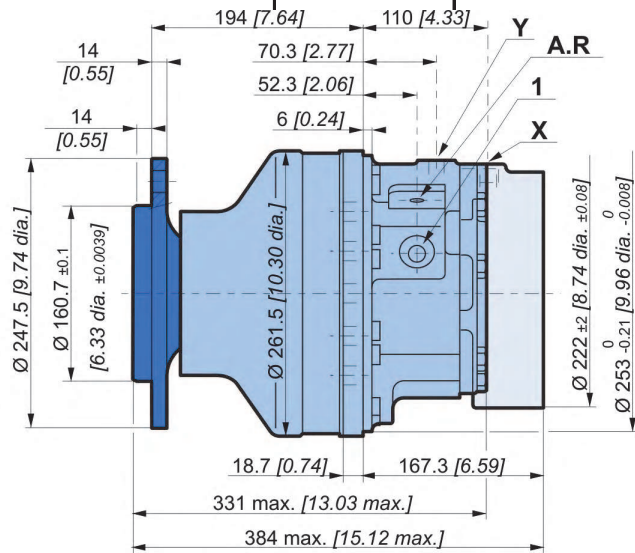

Dimensions for standard (1110) Twin-Lock™

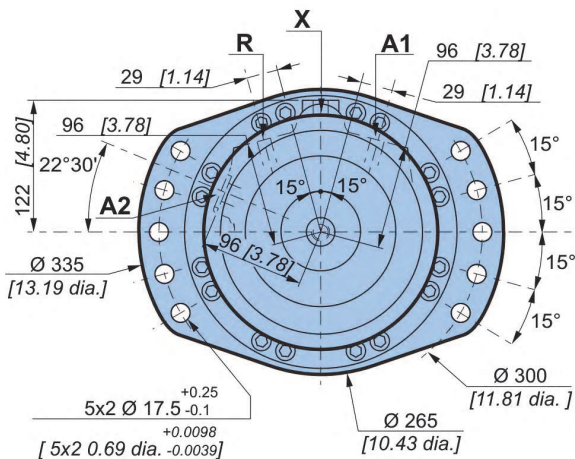

	65 kg [143 lb]	84 kg [185 lb]
	1,50 L [90 cu.in.]	1,00 L [60 cu.in.]

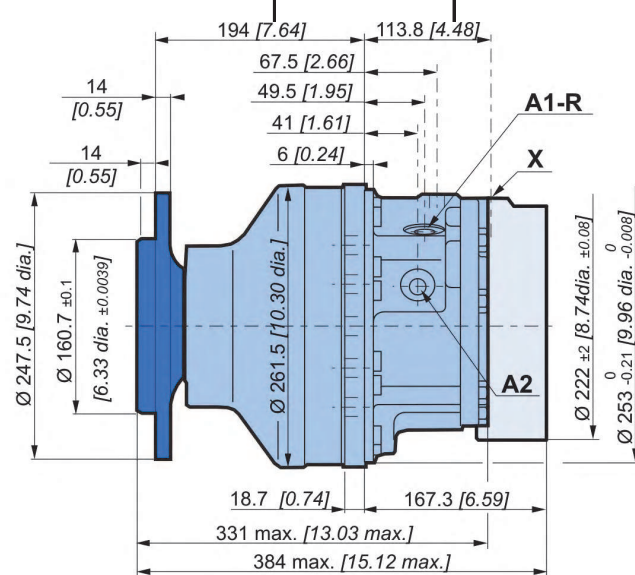

Modularity and Model code

Wheel motor

Shaft motor

Valving systems and hydrobases

Brake

Options







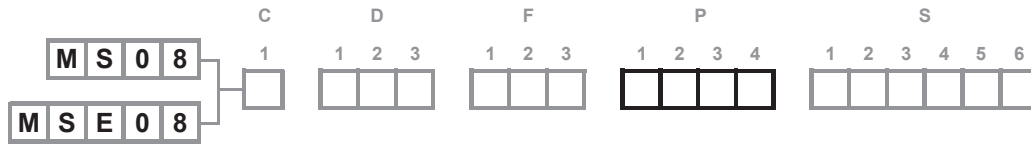

Also see 'Valving systems and hydrobases' section (thumbnail opposite).



Support types



C	A mm [in]	B mm [in]	C mm [in]	D mm [in]	E mm [in]	N mm [in]	Wheel rim mountings	L mm [in]
	Ø 160,7 [6,33 dia.]	Ø 205 [8,07 dia.]	Ø 245 [9,65 dia.]	195 [7,68]	Ø 261,5 [10,30 dia.]	6 x Ø 20 [6 x 0,79 dia.]	M18x1.5	13,5 [0,53]
	Ø 150,9 [5,94 dia.]	Ø 203,2 [8,00 dia.]	Ø 238 [9,37 dia.]	194,1 [7,64]	Ø 261,5 [10,30 dia.]	8 x Ø 22 [8 x 0,87 dia.]	M20x1.5	13,5 [0,53]
	Ø 175,7 [6,92 dia.]	Ø 225 [8,86 dia.]	Ø 270 [10,63 dia.]	188,8 [7,43]	Ø 261,5 [10,30 dia.]	10 x Ø 18 [10 x 0,71 dia.]	M16x1.5	15 [0,59]
	Ø 160,7 [6,33 dia.]	Ø 205 [8,07 dia.]	Ø 245 [9,65 dia.]	163 [6,42]	Ø 261,5 [10,30 dia.]	6 x Ø 20 [6 x 0,79 dia.]	M18x1.5	14 [0,55]
	Ø 117,5 [4,63 dia.]	Ø 152,4 [6,00 dia.]	Ø 181 [7,13 dia.]	163 [6,42]	Ø 261,5 [10,30 dia.]	6 x Ø 18 [6 x 0,71 dia.]	M14x1.5	11 [0,43]
	Ø 160,7 [6,33 dia.]	Ø 205 [8,07 dia.]	Ø 245 [9,65 dia.]	163 [6,42]	Ø 261,5 [10,30 dia.]	12 x M12	-	14,8 [0,58]

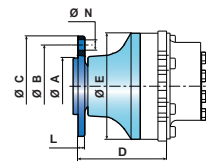
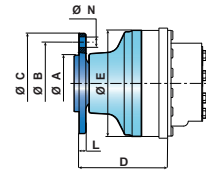

The supports in gray must not be assembled with an MSE hydrobase.



Load curves

Permissible radial loads

Test conditions :

Static : 0 tr/min [0 RPM] 0 bar [0 PSI]

Dynamic : 0 tr/min [0 RPM], code 0 displacement, without axial load at max. torque

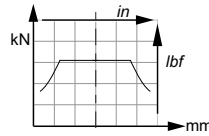

Service life of bearings

Test conditions :

L : Millions B10 revolutions at 150 bars (average pressure), with 25 cSt fluid, code 0 displacement, without axial load.

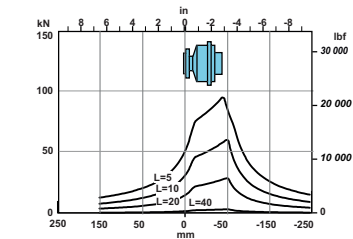
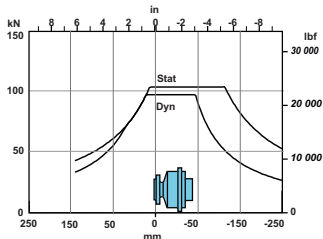
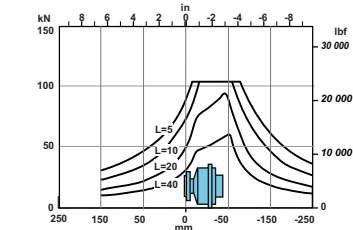
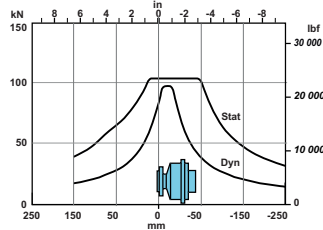
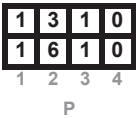
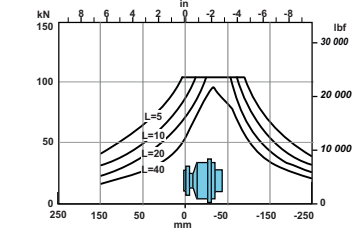
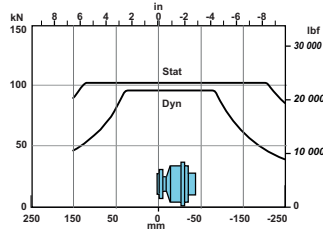
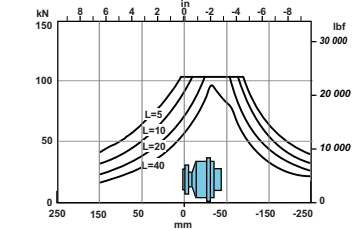
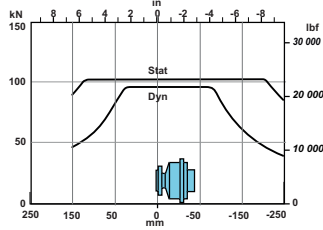
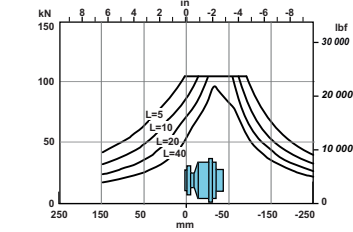
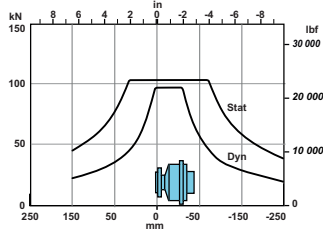

The service life of the components is influenced by the pressure. You must check that the combination of forces applied (Axial load / Radial load) is compatible with the permissible loads for the components, and that the resulting service lives of these components complies with the application's specifications. For an accurate calculation, consult your Poclair Hydraulics application engineer.

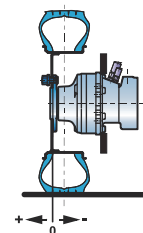

Modularity and Model code

Wheel motor

Shaft motor

Valving systems and hydrobases

Brake

Options



Support types (continued)

		C			D			F			P				S					
		1			1 2 3			1 2 3			1 2 3 4				1 2 3 4 5 6					
		MS08																		
		MSE08																		
C	A	B	C	D	E	N	Wheel rim mountings	L												
	mm [in]	mm [in]	mm [in]	mm [in]	mm [in]	mm [in]		mm [in]												
	Ø 117,5 [4,63 dia.]	Ø 165 [6,50 dia.]	Ø 186 [7,32 dia.]	163,2 [6,43]	Ø 261,5 [10,30 dia.]	12 x Ø 14 [12 x 0,55 dia.]	-	12 [0,47]												
	Ø 175,7 [6,92 dia.]	Ø 225 [8,86 dia.]	Ø 265 [10,43 dia.]	228,6 [9,00]	Ø 261,5 [10,30 dia.]	10 x Ø 24 [10 x 0,94 dia.]	M22x1.5	15 [0,59]												
 	Ø 160,7 [6,33 dia.]	Ø 205 [8,07 dia.]	Ø 286 [11,26 dia.]	255,8 [10,07]		6 x M18x1.5	30 [1,18]	Friction surface 270 x 60												
 	Ø 175,7 [6,92 dia.]	Ø 225 [8,86 dia.]	Ø 344 [13,54 dia.]	238,3 [9,38]		10 x M22x1.5	39 [1,54]	Friction surface 315 x 80												
	Ø 220,7 [8,69 dia.]	Ø 275 [10,83 dia.]	Ø 314 [12,36 dia.]	194 [7,64]	Ø 261,5 [10,30 dia.]	8 x Ø 22 [8 x 0,87 dia.]	M20x1.5	14 [0,55]												

Studs

		P	C min.	C max.	D	Class		(1) N.m [lb.ft]		(2) N.m [lb.ft]
		mm [in]	mm [in]	mm [in]	mm [in]					
Various studs	M14x1.5	45 [1,77]	5 [0,20]	15 [0,57]	16,5 [0,65]	12,9		200 [147,5]	250 [184,4]	
	M18x1.5	55 [2,17]		18 [0,71]	23 [0,91]			420 [309,8]	550 [405,7]	
	M18x1.5	65 [2,56]		23 [0,91]	25 [0,98]			600 [442,5]	770 [567,9]	
	M20x1.5	60 [2,36]		21 [0,83]	25 [0,98]			695 [512,6]	1 050 [774,4]	
	M22x1.5	55 [2,17]		15 [0,59]	26 [1,02]					
	M22x1.5	80 [3,15]		40 [1,57]						
Screws	M12x1.75	-	-	-	-	10,9		120 [88,5]	120 [88,5]	
	1/2"-20 UNF	-	-	-	-	10,9		250 [184,4]	120 [88,5]	

(*) The tightening torques are given for the indicated loads.

(1) **Wheel rim** : Suggested tightening torque for wheel rim mountings (Re steel disc > 240 N/mm² [>34 800 PSI]).

(2) **Standard** : Suggested tightening torque in other cases (Re steel flange 360 > N/mm² [>52 215 PSI])

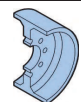

See generic installation motors N°801478197L.

Load curves (continued)



Permissible radial loads

Test conditions :

Static : 0 tr/min [0 RPM] 0 bar [0 PSI]

Dynamic : 0 tr/min [0 RPM], code 0 displacement, without axial load at max. torque

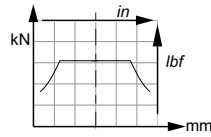

Service life of bearings

Test conditions :

L : Millions B10 revolutions at 150 bars (average pressure), with 25 cSt fluid, code 0 displacement, without axial load.

1	9	1	0
1	2	3	4

P

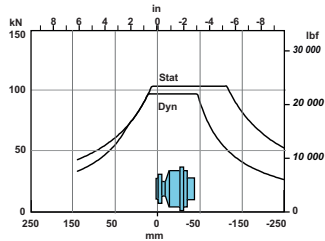

1	G	1	0
1	K	3	0
1	L	3	0
1	2	3	4

P

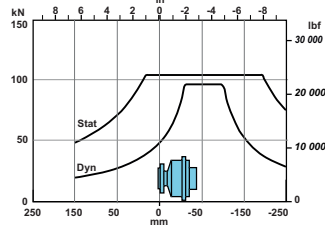

Friction surface 270 x 60

1	G	1	0
1	P	3	0
1	Q	3	0
1	2	3	4

P

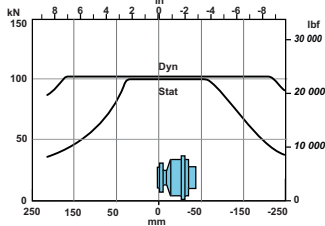

Friction surface 315 x 80

1	7	1	0
1	2	3	4

P

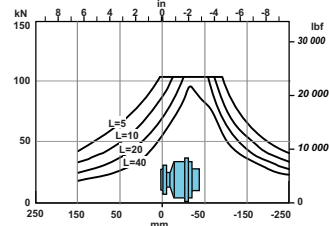
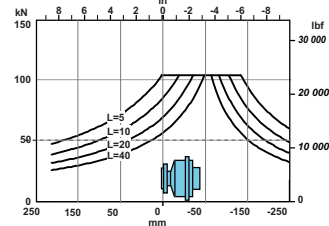
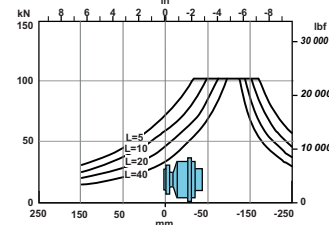
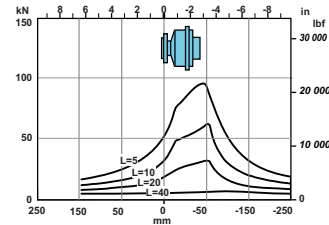
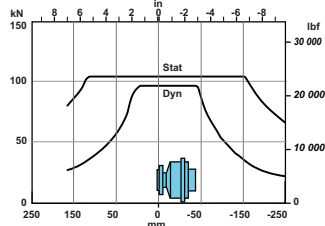

Modularity and Model code

Wheel motor

Shaft motor

Valving systems and hydrobases

Brake

Options



The service life of the components is influenced by the pressure. You must check that the combination of forces applied (Axial load / Radial load) is compatible with the permissible loads for the components, and that the resulting service lives of these components complies with the application's specifications. For an accurate calculation, consult your Poclain Hydraulics application engineer.

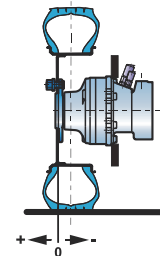





SHAFT MOTOR

Dimensions for standard (2A50) 1-displacement motor

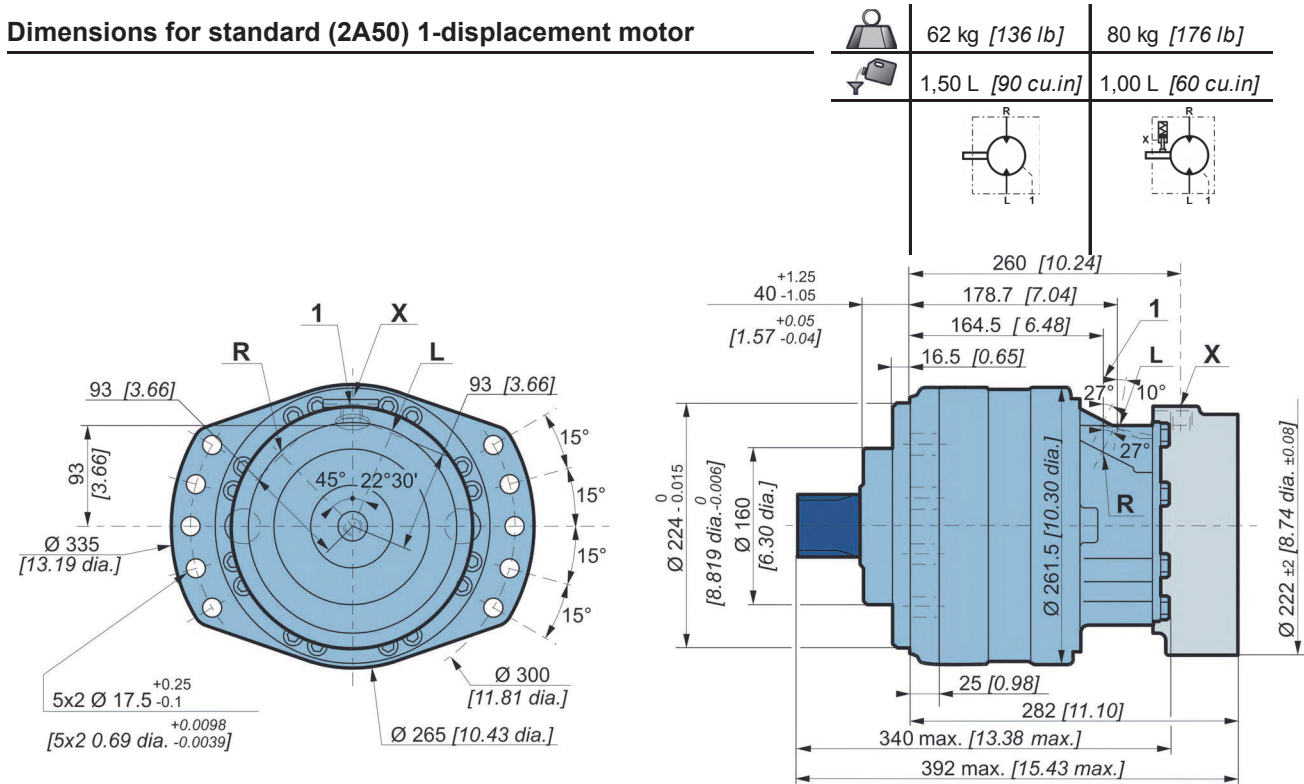

Dimensions for standard (2A50) 2-displacement motor

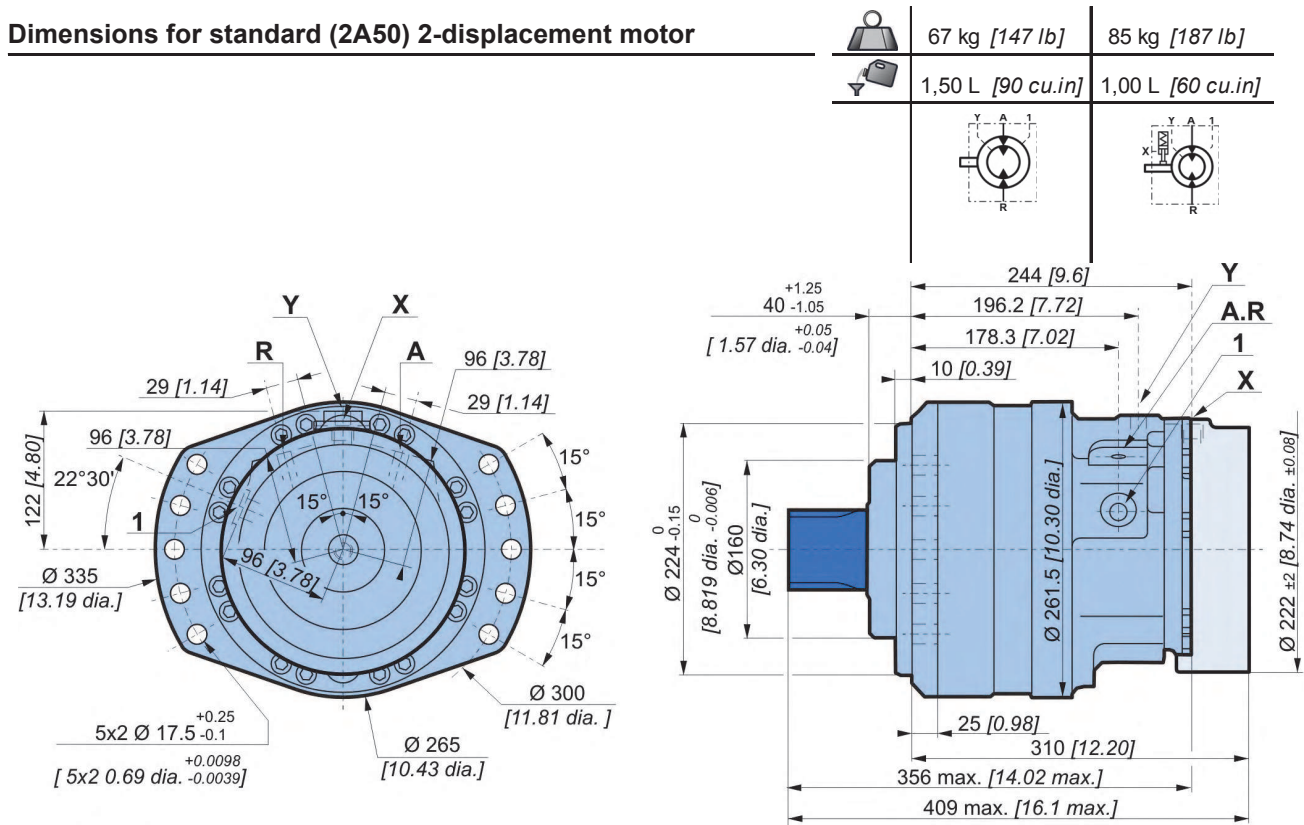

Also see 'Valving systems and hydrobases' section (thumbnail opposite).

Modularity and Model code

Wheel motor

Shaft motor

Valving systems and hydrobases

Brake

Options



Support types

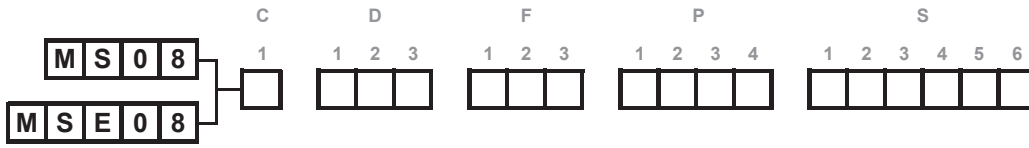

C				A	B	C	D	E	F
DIN 5480 splines									
2	A	5	0	15	R 2,5	35	2 x M10	23	70
1	2	3	4	[0,59]	[R 0,10]	[1,38]		[0,91]	[2,76]
Nominal Ø				70 [2,76]					
Module				3					
Z				22					
NF E22-141 splines									
2	A	1	0	15	R 2,5	35	2 x M10	24	70
1	2	3	4	[0,59]	[R 0,10]	[1,38]		[0,94]	[2,76]
Nominal Ø				65 [2,56]					
Module				2.5					
Z				24					

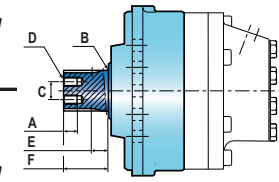

Also see 'Valving systems and hydrobases' section (thumbnail opposite).

Splined coupling

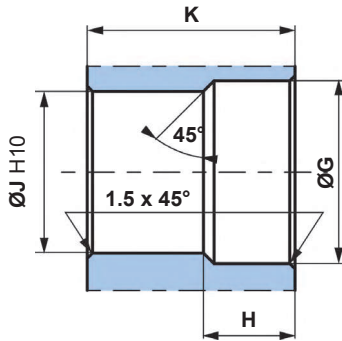

Standard NF E 22-141
 Pressure angle 20°.
 Centering on flanks.
 Slide adjustment (7H quality).

Standard DIN 5480
 Pressure angle 30°.
 Centering on flanks.
 Slide adjustment (7H quality).

N : Nominal Ø.
Mo : Module.
Z : Number of teeth.

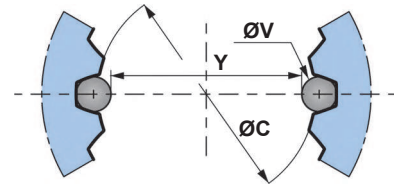

C				Ø G	H	Ø J	K	N	Mo	Z	Offset	Ø C (H10)	Ø V	Y	Tolerance µm [µin]
2	A	1	0	66	25	60	69	65	2,5	24	2	60	5	55,169	+ 86 / 0
1	2	3	4	[2,60]	[0,98]	[2,36]	[2,72]	[2,56]			[0,08]	[2,36]	[0,20]	[2,17]	[+3.386 / 0]
Nominal Ø				65 [2,56]											
Module				2.5											
Z				24											
DIN 5480															
2	A	5	0	71,5	25	64	69	70,0	3	22	+0,35	64,0	5,25	59,042	+ 76 / +28
1	2	3	4	[2,81]	[0,98]	[2,52]	[2,72]	[2,76]			[+0,0138]	[2,52]	[0,21]	[2,32]	[+2.992 / +1.1]
Nominal Ø				70 [2,76]											
Module				3											
Z				22											

General tolerances : ± 0.25 [±0.0098].

Material: Ex: 42CrMo4.

Hardening treatment to obtain R = 800 to 900 N/mm² [R = 116 030 to 130 533 PSI].



Radial load and service life of bearings curves



The service life of the components is influenced by the pressure. You must check that the combination of forces applied (Axial load / Radial load) is compatible with the permissible loads for the components, and that the resulting service lives of these components complies with the application's specifications. For an accurate calculation, consult your Poclain Hydraulics application engineer.

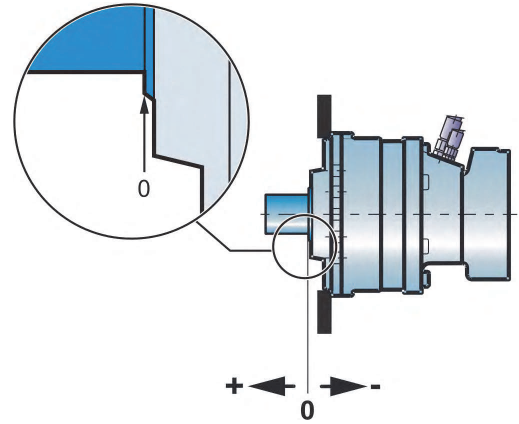

Permissible radial loads

Max. permissible loads: 0 tr/min [0 RPM]; 0 bar [0 PSI]

Continuous permissible loads:
> 0 tr/min [> 0 RPM]; 275 bar [3 988 PSI].

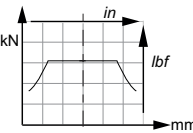

Service life of bearings

Test conditions : Test conditions :

L : Millions B10 revolutions at 150 bars (average pressure), with 25 cSt fluid, code 0 displacement, without axial load.

2 A 5 0
1 2 3 4
P

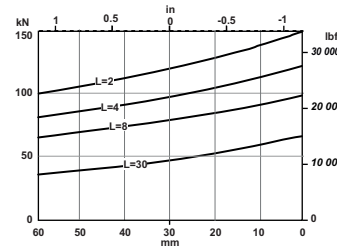
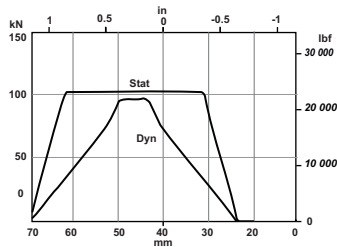

2 A 1 0
1 2 3 4
P

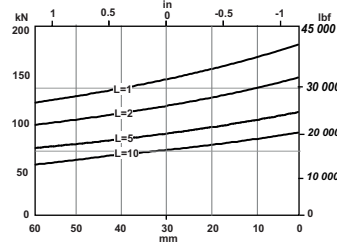
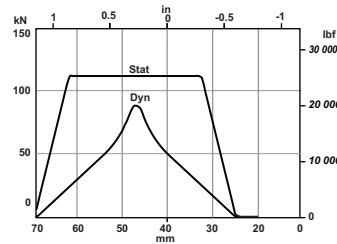

Modularity and Model code

Wheel motor

Shaft motor

Valving systems and hydrobases

Brake

Options





VALVING SYSTEMS AND HYDROBASES

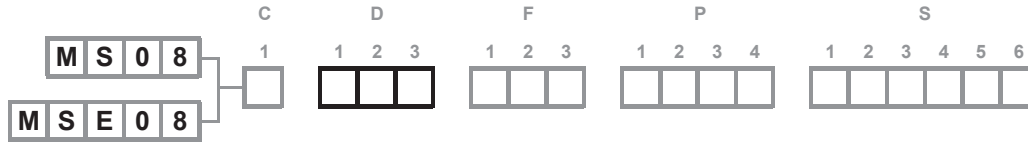

Dimensions for 1-displacement valving

	34,4 kg [76 lb]	51,8 kg [114 lb]
	0,50 L [30 cu.in]	1,00 L [60 cu.in]

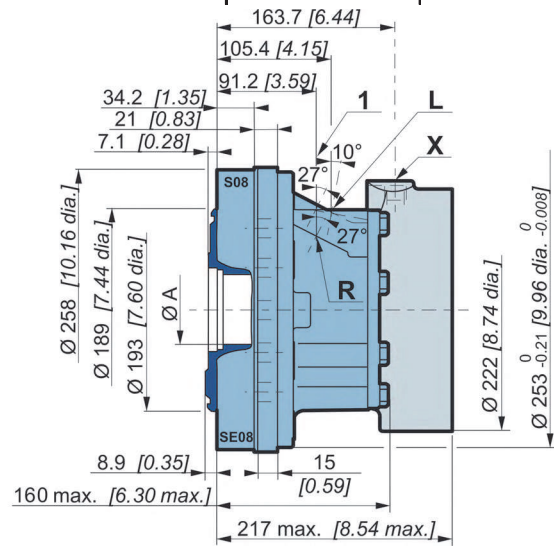
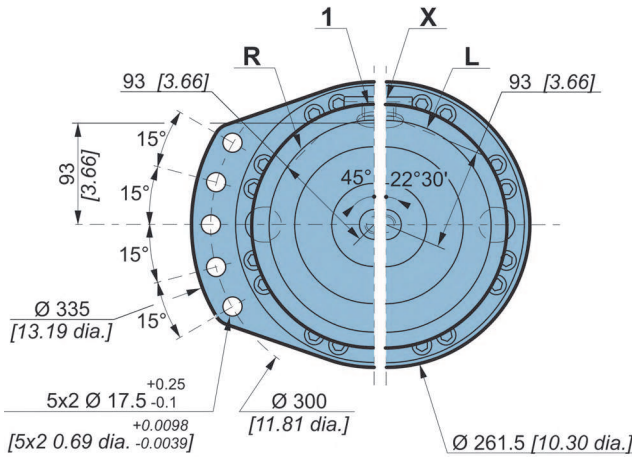

Cylinder block splines

(as per standard NF E22-141)

ØA	Module	Z	Dimension on 2 pins	
			Y	ØV
60 [2,362]	2,5	24	69,580 [2,739]	4,5 [0,177]

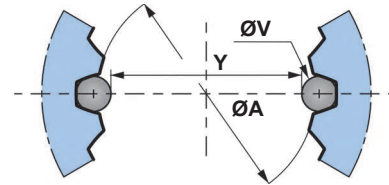

You are advised to have the installation validated by your Poclain Hydraulics application engineer before using the hydraulic unit in an application.



We must provide you with a detailed plan of the interface for any hydraulic unit use, consult your Poclain Hydraulics sales engineer.

Modularity and Model code

Wheel motor

Shaft motor

Valving systems and hydrobases

Brake

Options



Dimensions for one-piece valving single displacement

	35 kg [77 lb]
	0,50 L [30 cu.in]

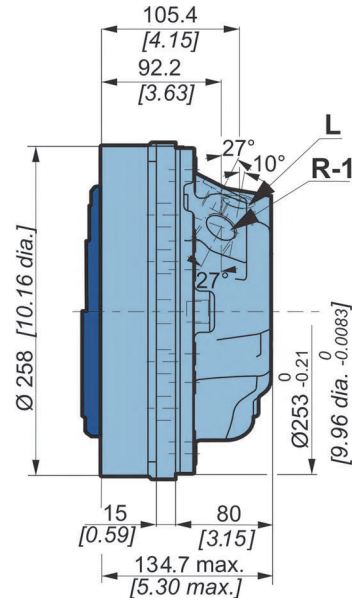
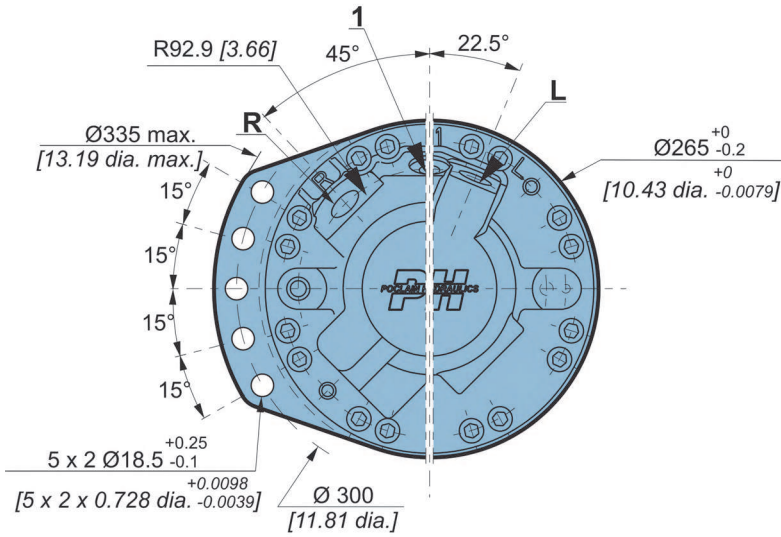
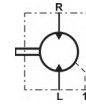

Dimensions for 2-displacement valving

	37,8 kg [83 lb]	54,7 kg [120 lb]
	0,50 L [30 cu.in]	1,00 L [60 cu.in]

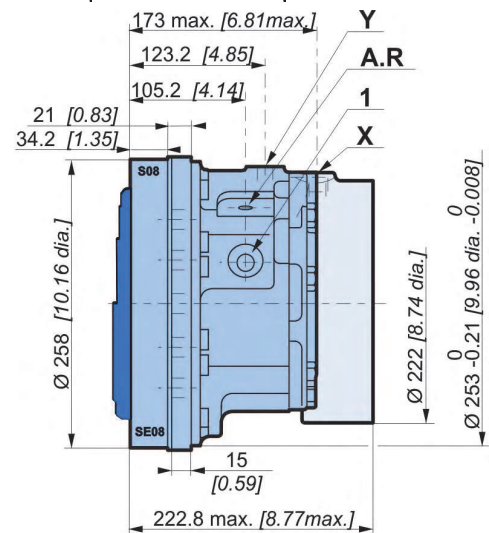
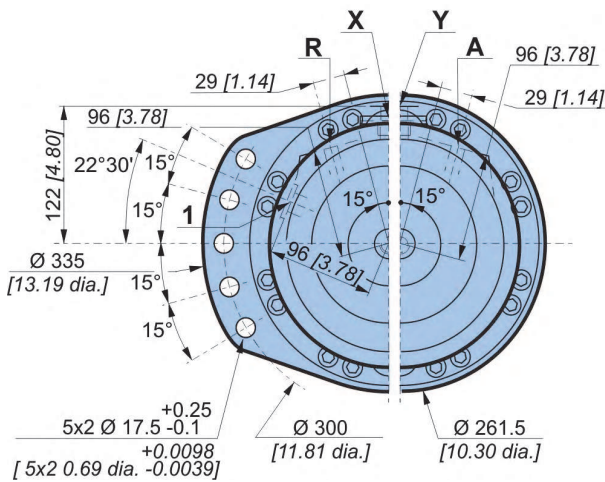



Dimensions for Twin-Lock™ valving

	37,8 kg [83 lb]	54,7 kg [120 lb]
	0,50 L [30 cu.in]	1,00 L [60 cu.in]

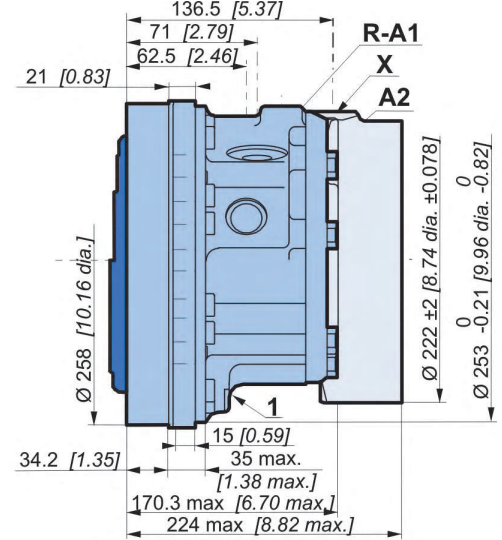
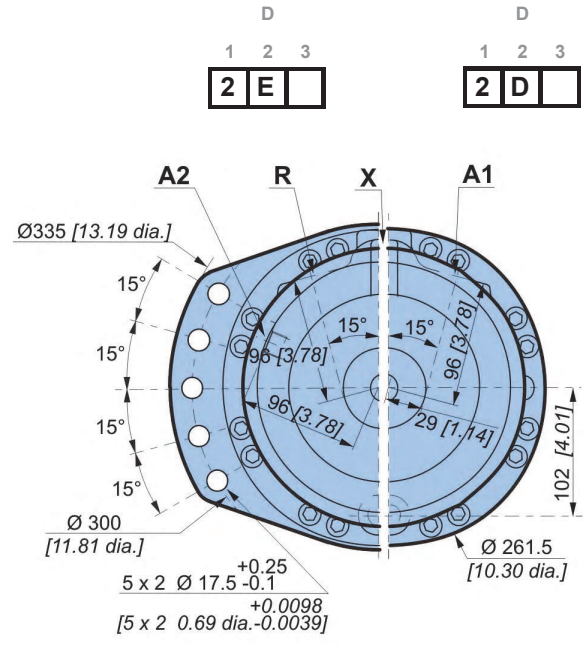

Dimensions for 1-displacement valving with built-in exchange

	34,4 kg [76 lb]	51,8 kg [114 lb]
	0,50 L [30 cu.in]	1,00 L [60 cu.in]

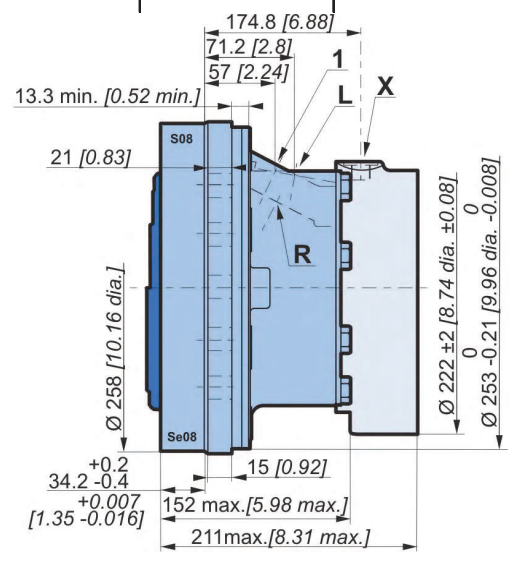
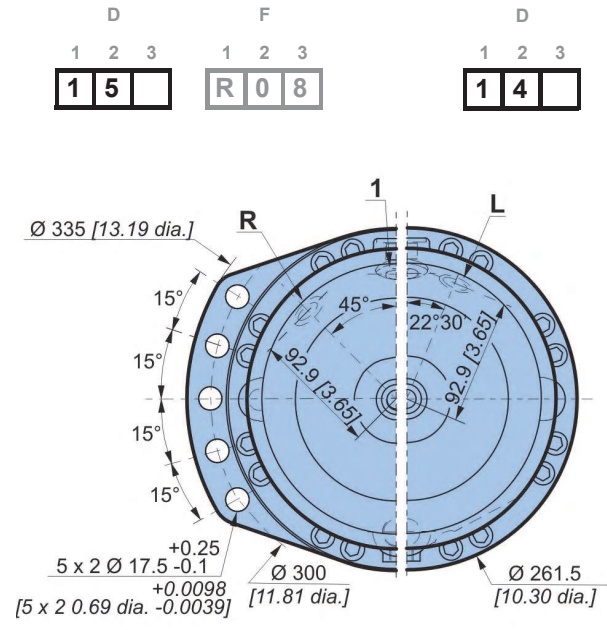

Modularity and Model code

Wheel motor

Shaft motor

Valving systems and hydrobases

Brake

Options



Exchange

When a coding request is made, you must specify information on the threshold of the selector and the valve.

Selector spool

Selector threshold bar [PSI]	Opening pressure of selector bar [PSI]
8 [116]	9.9 ±1.2 [144 ±17]

Fitted valve

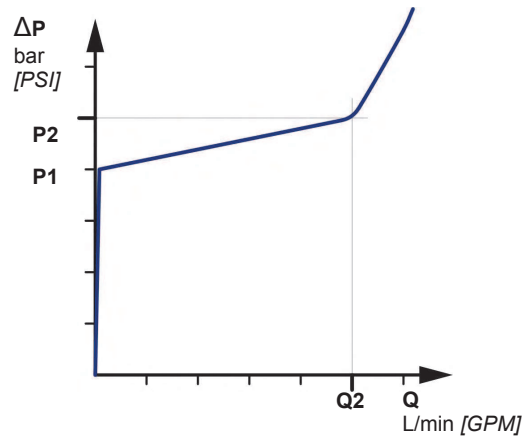

P1 bar [PSI]	Q2 L/min [GPM]	P2 bar [PSI]
13.5 [195]	14 [3.7]	16 [232]
18 [261]	15 [3.9]	21 [305]
22 [319]	16 [4.2]	25 [363]

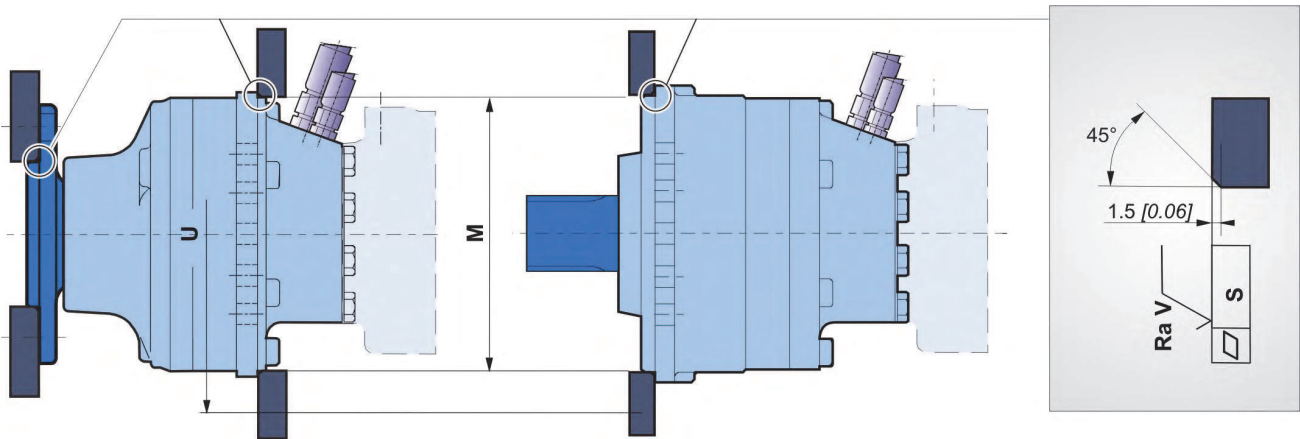

Chassis mountings



Take care over the immediate environment of the connections.

	ØM ⁽¹⁾	ØU	S	Ra V		Class	 *
Wheel motor	253 [9,96]	300 [11,81]	0,2	12,5µm	2 x 5	8,8	210 Nm [155 lb.ft]
Shaft motor	224 [8,82]	300 [11,81]	[0,008]	[0,49µin]	M16 x 2		

(1) +0,3 [+0,012]
+0,2 [+0,008]

* : Min. values for torque and load to be transmitted.



See generic installation motors N°801478197L.



Hydraulic connections

connections

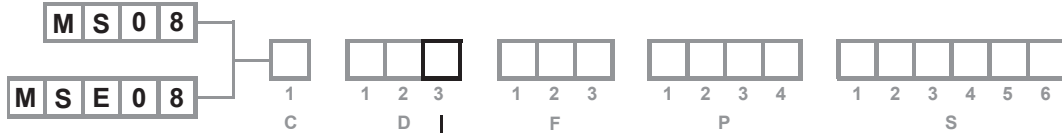
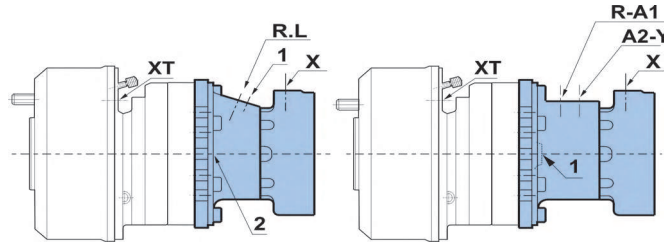

	Old standards	Standards	Power supply	Case drain	2 nd displacement control	Control of parking break	Control of drum break
			R-L	1, 2		X	XT
	A	SAE J514 ISO 11 926-1	1"1/16-12 UNF	3/4"-16 UNF		9/16"-18 UNF	
	1	ISO 6 162 DIN 3 852 ISO 9 974-1	DN13 PN400	M18x1.5		M16x1.5	
	2	ISO 6 162 BSPP ISO 1 179-1	DN13 PN400	Ø17 [3/8" dia.]		Ø17 [3/8" dia.]	
	4	NF E48 050 ISO 9 974-1	M22x1.5	M18x1.5		M16x1.5	
	5	DIN 3 852 ISO 9 974-1	M27x2	M18x1.5		M16x1.5	
	8	NF E48 050 ISO 6 149-1	M22x1.5	M18x1.5		M16x1.5	
			R-A	1, 2	Y	X	
	A	SAE J514 ISO 11 926-1	1"1/16-12 UNF	3/4"-16 UNF	9/16"-18 UNF	9/16"-18 UNF	
	1	ISO 6 162 DIN 3 852 ISO 9 974-1	DN13 PN400	M18x1.5	M14x1.5	M16x1.5	
	5	DIN 3 852 ISO 9 974-1	M27x2	M18x1.5	M14x1.5	M16x1.5	
			R-A1-A2	1, 2	Y	X	
	A	SAE J514 ISO 11 926-1	1"1/16-12 UNF	3/4"-16 UNF	9/16"-18 UNF	9/16"-18 UNF	
	3	BSPP ISO 1 179-1	Ø27 [3/4" dia.]	Ø17 [3/8" dia.]	Ø13 [1/4" dia.]	Ø13 [1/4" dia.]	
	5	DIN 3 852 ISO 9 974-1	M27x2	M18x1.5	M14x1.5	M16x1.5	
		ISO 9 974-1					M12x1.5 M14x1.5
Max. pressures	MS	bar [PSI]	450 [6 527]	1 [15]	30 [435]	30 [435]	120 [1 740]
	MSE		400 [5 802]				



You are strongly advised to use the fluids specified in brochure "Installation guide" N° 801478197L.



To find the connections' tightening torques, see the brochure "Installation guide" N° 801478197L.



Do not put either a check valve or a poppet valve on the pilot lines (parking brake and displacement change) between the charge pump and the pilot valve. Do not use a piloting valve with integrated check valve.

Modularity and Model code

Wheel motor

Shaft motor

Valving systems and hydrobases

Brake

Options



Efficiency

Overall efficiency

Average values given for guidance for code 0 displacement after 100 hours of operation with HV46 hydraulic fluid at 50°C [122°F].

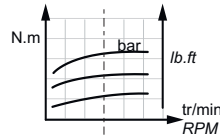
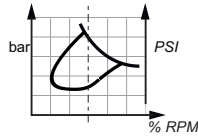

Actual output torque

MS08

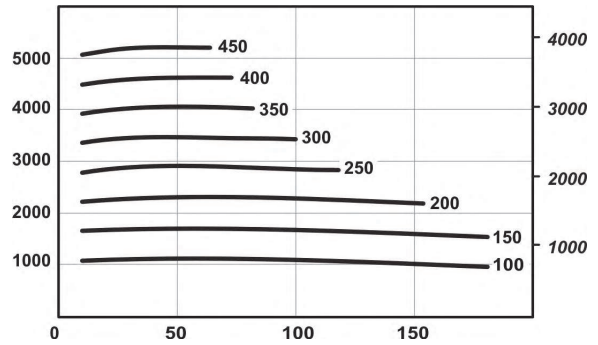
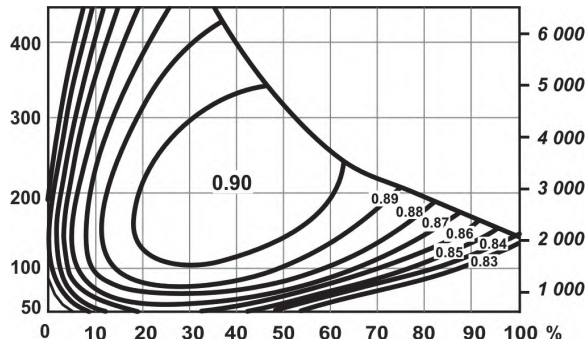

MSE08

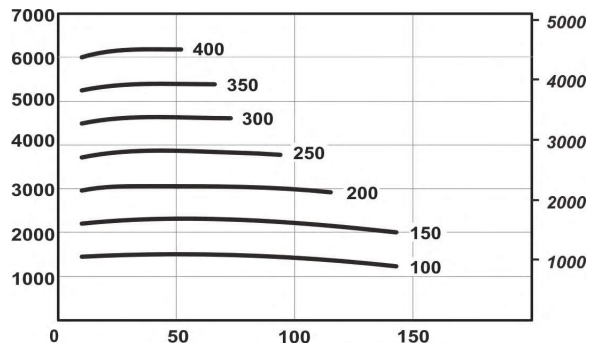
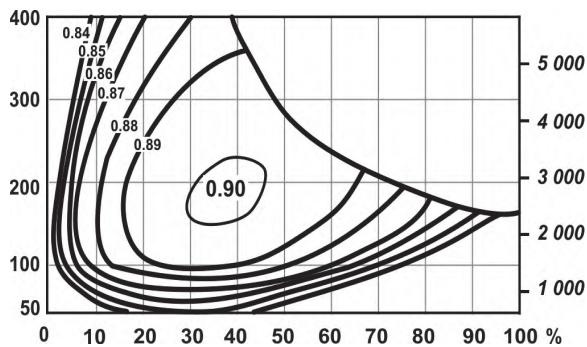

The starting torque is taken to be approximately 85% of the first value for available pressure. For a precise calculation, consult your Poclain Hydraulics application engineer.



BRAKES

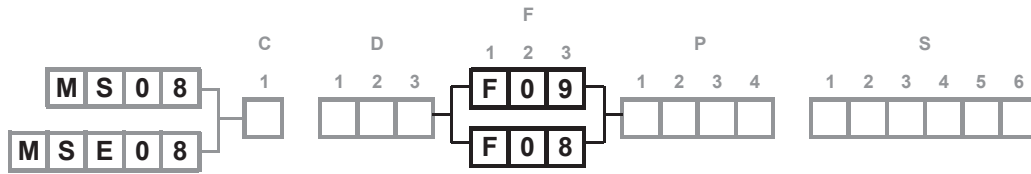

Rear brake

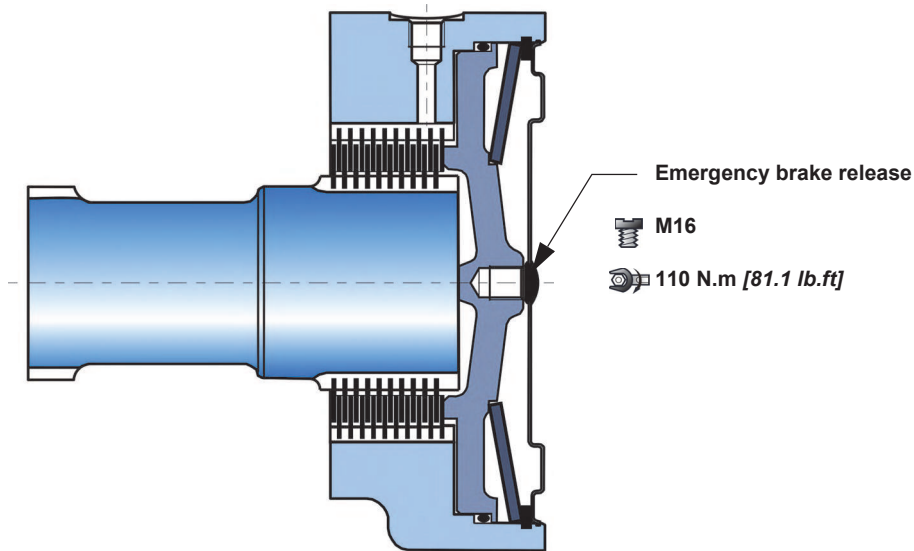

Brake principle

This is a multidisc brake which is activated by a lack of pressure. The spring exerts a force on the piston, which presses on the fixed and mobile discs, and immobilizes the shaft. The braking torque decreases in linear proportion to the brake release pressure.

C	F 0 8	F 0 9
Parking brake torque at 0 bars on housing (new brake)	5 620 Nm [4 150 lb.ft]	9 000 Nm [6 640 lb.ft]
Dynamic emergency braking torque at 0 bars on housing (max. 10 uses of emergency brakes)	3 653 Nm [2 690 lb.ft]	5 850 Nm [4 310 lb.ft]
Residual parking braking at 0 bars on housing *	4 215 Nm [3 110 lb.ft]	6 750 Nm [4 980 lb.ft]
Min. brake release pressure	12 bar [174 PSI]	12 bar [174 PSI]
Max. brake release pressure	30 bar [435 PSI]	30 bar [435 PSI]
Oil capacity	100 cm ³ [6,1 cu.in]	100 cm ³ [6,1 cu.in]
Volume for brake release	40 cm ³ [2,4 cu.in]	40 cm ³ [2,4 cu.in]
Max. energy dissipation		110 336 J

* After emergency brake has been used



Do not run-in the multidisc brakes.



A functional check of the parking brake must be carried out each time it is used as an auxiliary brake (or emergency brake). For all vehicles capable of speeds over 25 km/hour, please contact your Poclain Hydraulics application engineer.

Modularity and Model code

Wheel motor

Shaft motor

Valving systems and hydrobases

Brake

Options



Drum brake (270 x 60 or 315 x 80)

Diameter of brake pads : Ø 270 [7.99 dia.] or Ø 315 [12.4 dia]
 Width of friction surface : 60 [2.36] or 80[3.15]

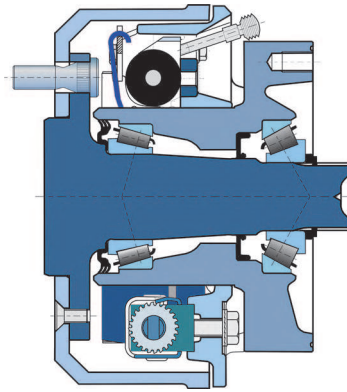
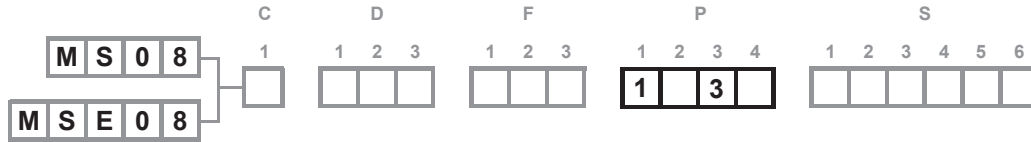

Brake pads	270 x 60	315 x 80
Asbestos free material	BERAL 1109	BERAL 1518
Compensation for wear		
Hydraulically controlled dynamic braking	Automatic	Automatic
Max. permissible continuous brake torque	3 600 N.m [2 655 lb.ft]	7 200 N.m [5 310 lb.ft]
Pressure to obtain max. permissible continuous brake torque	74 bar [1 073 PSI]	71 bar [1 030 PSI]
Max. permissible brake torque	6 000 N.m [4 425 lb.ft]	12 000 N.m [8 851 lb.ft]
Pressure to obtain max. permissible brake torque	120 bar [1 740 PSI]	120 bar [1 740 PSI]
Fluid		
Mineral	C K Yes	C P Yes
DOT 3/DOT4/SAE J1703	L Yes	Q Yes
Max. volume required to bring pads into contact	8,6 cm³ [0,52 cu.in]	5,4 cm³ [0,33 cu.in]
Mechanically controlled parking brake		
Max. braking torque	6 000 N.m [4 425 lb.ft]	12 000 N.m [8 851 lb.ft]
Max permissible force on the cable	2 000 N [450 lbf]	3 800 N [854 lbf]
Force required to bring pads into contact	38 N [9 lbf]	64 N [14 lbf]
Stroke required to bring pads into contact	A 13,0 mm [0,51 "]	12,0 mm [0,47 "]
	B 11,5 mm [0,45 "]	10,5 mm [0,41 "]
Max. stroke before automatic brake adjustment	A 11,3 mm [0,44 "]	14,5 mm [0,57 "]
	B 10,0 mm [0,39 "]	12,5 mm [0,49 "]

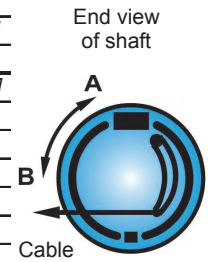

The max. braking torque can only be obtained when the brake has been run in. Consult your Poclair Hydraulics application engineer.

Control

The drum brakes can be controlled hydraulically (service brake) and by a cable (mechanical control for parking brake).



Do not use hydraulic and mechanical brake controls simultaneously.



See also 'Wheel motor' section (thumbnail opposite).



When making an encoding request, you must indicate the following information:
 - The material of the brake linings,
 - The type of connection at the end of the parking brake control cable,
 - Fill out the technical questionnaire for validation of the brake.



OPTIONS



You can accumulate more than one optional part. Consult your Poclain Hydraulics sales engineer.

1 - Fluorinated elastomer seals

Nitrile seals marked in the figure below replaced by fluorinated elastomer seals.

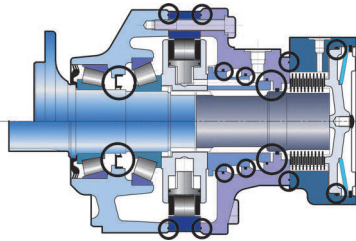

Consult your Poclain Hydraulics sales engineer.

2 - S - Q - 8 - Installed speed sensor or predisposition

Designation

T4 speed sensor (without rotation direction)	2
TR speed sensor (digital rotation direction)	S
TD speed sensor (two phase shifted frequencies)	Q
Predisposition for speed sensor	8

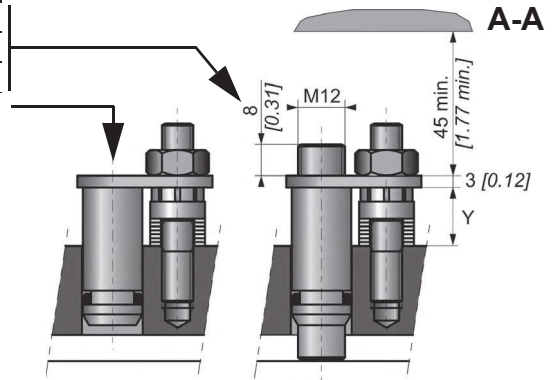
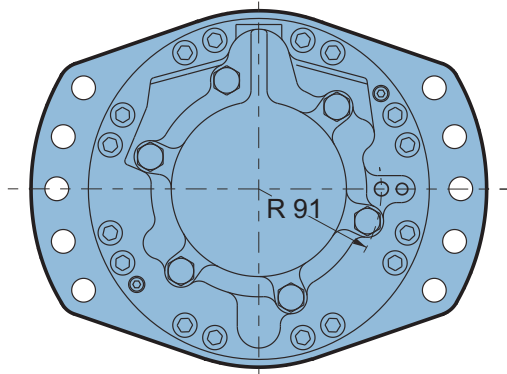

Max. length Y= 21.1

Standard number of pulses per revolution= 60



Look at the "Mobile Electronic" N° A01889D technical catalogue for the sensor specifications and its connection.



To install the sensor, see the "Installation guide" brochure No. 801478197L.

Modularity and Model code

Wheel motor

Shaft motor

Valving systems and hydrobases

Brake

Options



3 - Brake environmental cover without plug

No plug or hole in the cover.
(see figure opposite)

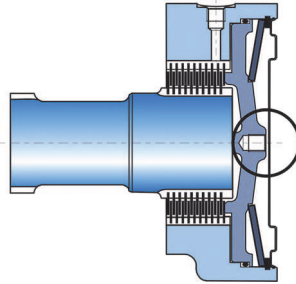

5 - Drainage

Fit an additional drain on the valving cover.

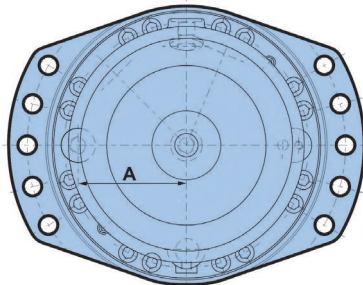

A
102 [4.02]

6 - Industrial support

Reduction of around 50% from the rated value in the bearings' preload value.



For a precise calculation, consult your Poclain Hydraulics application engineer.

7 - Diamond™

Special treatment of the motor core which considerably increases its strength, making the motor much more tolerant to temporary instances of the operating conditions being exceeded.

A - Hollow shaft

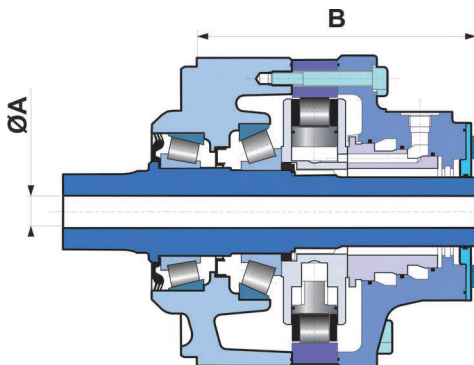

A	B
mm [in]	mm [in]
Ø 35 [1.38 dia.]	231.2 [9.10]

Radial load x 0.75
No torque allowed towards the rear



B - Drain on the bearing support

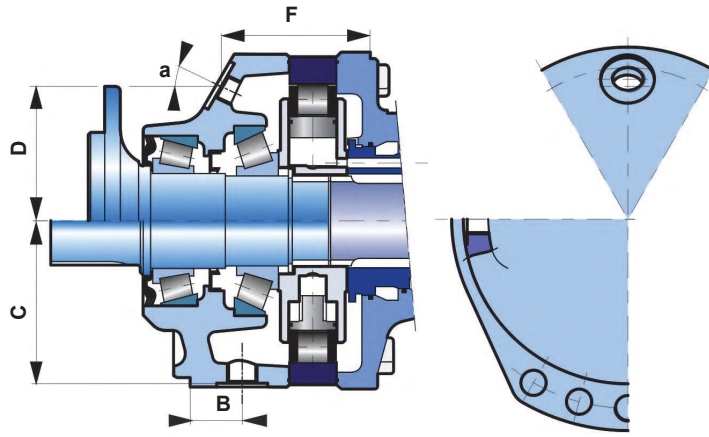

	ISO 6419-1	B mm [in]	C mm [in]	D mm [in]	F mm [in]	a
Shaft motor	M18 x 1.5	37.5 [1.5]	129 [5.08]			
Wheel motor	M18 x 1.5			105 [4.13]	89.5 [3.52]	35°
Short wheel motor	M18 x 1.5			97 [3.82]	95 [3.74]	30°

C - Abrasive environments (mechanical seal)

Certain environments can be very harmful. The mirror seal gives reinforced motor sealing.



Consult your Poclain Hydraulics sales engineer.

E - Reinforced sealing

Requires reinforcement of shaft bearings.

G - Special wheel rim mounting

Enables certain combinations different from the standard mountings defined on pages 11 and 13.



Consult your Poclain Hydraulics sales engineer.

J - Treated shaft

Heat treatment on the indicated bearing radius and splines.

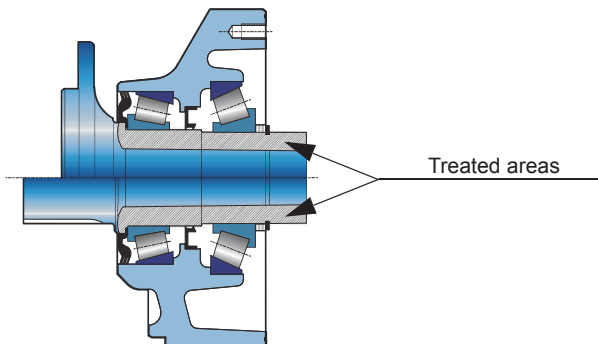

M - High speed

Under certain conditions, an increase in the maximum speed of 30% above the values indicated in the table on page 2 is possible.



For a precise calculation, consult your Poclain Hydraulics application engineer.

Modularity and Model code

Wheel motor

Shaft motor

Valving systems and hydrobases

Brake

Options



T - Soft Shift™

Progressive displacement change (cushioned slide-valve)

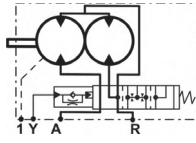









Consult your Poclain Hydraulics sales engineer.





*Poclain Hydraulics reserves the right to make any modifications it deems necessary to the products described in this document without prior notification. The information contained in this document must be confirmed by Poclain Hydraulics before any order is submitted.
Illustrations are not binding.
The Poclain Hydraulics brand is the property of Poclain Hydraulics S.A.*

-  03/09/2014
-  801 478 119B
-  801 478 189C
-  801 578 102D
-  801 578 114R
-  801 578 126E
-  A07442P
-  Not available
-  A14241E

