



Hydraulic Valves



Hydraulic Valves

Poclain Hydraulics specializes in the design, manufacture and marketing of hydrostatic transmissions.

Our success is based on a wide range of products, our high quality standards and a strong culture of innovation.

4 Open Loop Valves

- Check Valves
- Pressure Control Valves
- Flow Control Valves
- Directional Control Valves
- Compact connecting components

Poclain Hydraulics Open Loop Valves are designed and optimized for hydraulic systems with pressure range up to 350 bar. This product range can easily be used in closed loop systems as well.

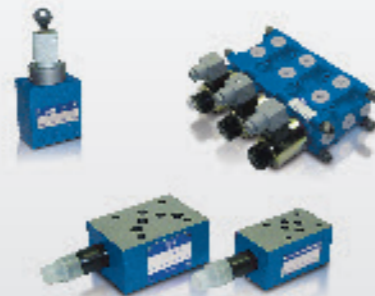

10 Brake Valves

- Brake Actuators
- Power Brake Valves
- Tractors & Trailers Brake Valves
- Accumulator charging Valves

Poclain Hydraulics has developed braking system to both enhance hydrostatic braking performance and add synchronized control for combinations of both hydrostatic and mechanical brake systems on a single vehicle. This product range is designed to be easily integrated to an existing braking circuit.



12 Power transmission Valves

- Traction Control Valves
- Flow Control Valves
- Freewheeling Valves
- Exchange Valves

Designed for hydrostatic transmission, these valves are sized to operate at high pressure & high flow. They are optimized to work with Poclain Hydraulics hydrostatic transmission.

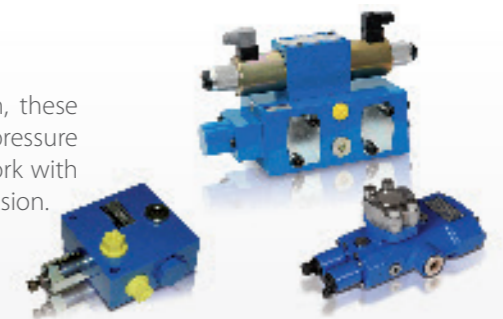

14 Customized block Valves

Power Transmission Valves & Open Loop Valves can be integrated into blocks meeting any customer's needs.

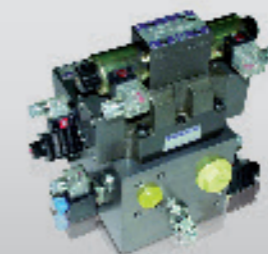

Check Valves

A large connecting and modular offer.

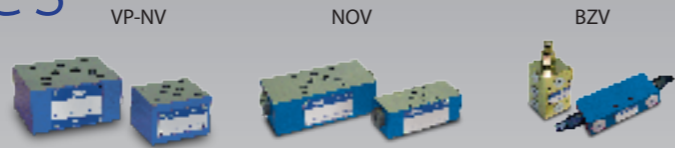

Size (NG)			Operating pressure bar [PSI]	Flow rate l/min [GPM]	Connecting dimensions*	Hydraulic schematics
6	10					

Direct operated valves

VP-NV	■	■	350 [5 076]	100 [26.4]	CETOP	
VP-NOV	■	■	350 [5 076]	100 [26.4]	CETOP	

Pilot operated valves

NOV-6D	■		350 [5 076]	60 [15.9]	in line Gas, UNF	
NOV-6E	■	■	350 [5 076]	60 [15.9]	in line Gas, UNF	

Counterbalance piloted valves

BZV	■		270 [3 916]	60 [15.9]	in line Metric, Gas, UNF	
VP-BZV	■		270 [3 916]	60 [15.9]	CETOP	

Pressure Valves

Different mounting systems and direct/pilot operated valves.



	Size (NG)			Operating pressure bar [PSI]	Flow rate l/min [GPM]	Connecting dimensions*	Operation	Hydraulic schematics
	4	6	10					
VVP	■	■		400 [5 802]	120 [31.7]	Cartridge in line	Direct	
VVB2			■	210 [3 046]	60 [15.9]	in line Metric, Gas, UNF	Direct	
VPLB15				Please consult our application engineers		in line Metric	Direct	
RT	■	■	■	350 [5 076]	90 [23.8]	Cartridge	Size 4: direct Sizes 6 to 10: pilot	
VP-RT		■	■	350 [5 076]	90 [23.8]	CETOP	Pilot	

Flow control Valves

2 or 3 ways valves, pressure compensated.

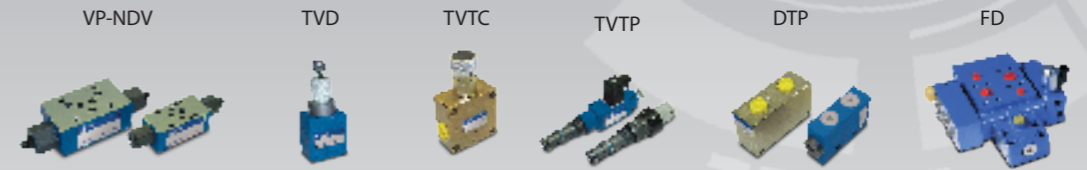

Size (NG)			Operating pressure bar [PSI]	Flow rate l/min [GPM]	Connecting dimensions*	Setting method	Hydraulic schematics
6	10						

Throttle/check valve

VP-NDV	■	■	350 [5 076]	100 [26.4]	CETOP	Manual	
--------	---	---	-------------	------------	-------	--------	--

Pressure compensated flow control valves

TVD	■		350 [5 076]	16 [4.2]	CETOP (ISO 6264)	Manual, Mechanical	
TVTC	■		350 [5 076]	50 [13.2]	in line Metric, Gas, UNF	Manual	
TVTP Proportional	■		350 [5 076]	90 [23.8]	cartridge in line Gas, UNF	Electric, manual	

Flow dividers

DTP	■	■	350 [5 076]	70 [18.5]	in line Metric, Gas, UNF		
FD			450 [6 526]	300 [80]	in line Metric, Gas, UNF	Electric, hydraulic	



*Connecting dimensions: Metric = ISO 9974; Gas = ISO 1179; UNF = ISO 11926-1, CETOP = ISO 4401

*Connecting dimensions: Metric = ISO 9974; Gas = ISO 1179; UNF = ISO 11926-1, CETOP = ISO 4401

Directional control Valves



A wide range of spool types; low pressure drops; high reliability.

- Up to 250 bar [3 600 PSI] on the T port
- Up to 350 bar [5 077 PSI] on the working ports
- A large range of 6/2, 8/3 selector valves

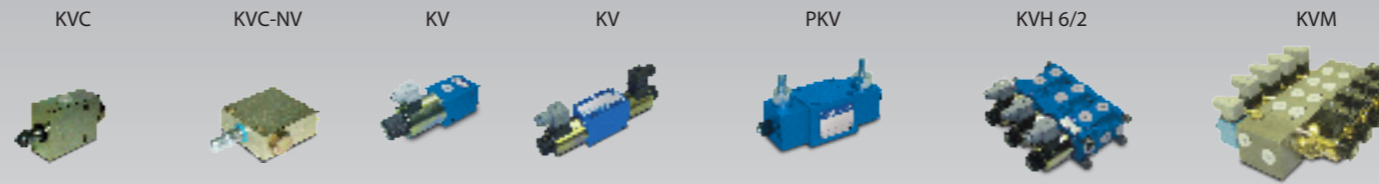

Size (NG)				Operating pressure bar [PSI]	Flow rate l/min [GPM]	Actuation	Modular Mounting*	Non modular in line connection	Hydraulic schematics (examples)
4	6	10	16						

Size (NG)				Operating pressure bar [PSI]	Flow rate l/min [GPM]	Actuation	Modular Mounting	Non modular in line connection*	Hydraulic schematics (examples)
4	6	10	16						

2/2

KV poppet		■			210 [3 046]	30 [7.9]	Electrical		Metric, Gas, UNF	
KVC	■				250 [3 626]	35 [9.2]	Mechanical		Metric, Gas, UNF	
KVC-NV		■			250 [3 626]	40 [10.5]	Mechanical		Metric, Gas, UNF	

6/2

KV		■	■		350 [5 077]	120 [31.6]	Mechanical		Metric, Gas, UNF	
KV		■			350 [5 077]	50 [13.2]	Electrical		Metric, Gas, UNF	
KV			■		350 [5 077]	120 [31.6]	Electrical		Metric, Gas, UNF	
KV-6K/2		■			250 [3 626]	50 [13.2]	Electrical		Metric, Gas, UNF	
KV 6/2				■	350 [5 077]	250 [65.8]	Electrical		Gas, UNF	
KVH		■			315 [4 569]	50 [13.2]	Electrical	Bankable	Metric, Gas, UNF	
KVH 6/2				■	315 [4 569]	120 [31.6]	Electrical	Bankable	Metric, Gas, UNF	

3/2

KVC	■				160 [2 320]	16 [4.2]	Electrical		Metric, Gas	
KVC			■		350 [5 077]	100 [26.4]	Electrical		Metric, Gas, UNF	

4/2

PKV		■	■		210 [3 046]	60 [15.8]	Automatic	CETOP		
PKV-T		■			210 [3 046]	30 [7.9]	Automatic	CETOP		

4/2 and 4/3

KV		■	■		350 [5 077]	100 [26.4]	Mechanical	CETOP		
KV		■			350 [5 077]	75 [19.8]	Electrical	CETOP		
KV			■		350 [5 077]	120 [31.6]	Electrical	CETOP		
KV		■	■		350 [5 077]	130 [34.2]	Hydraulic	CETOP		
KV (3kO)		■			250 [3 626]	40 [10.5]	Electrical	CETOP		
KV				■	350 [5 077]	300 [79]	Electrical	CETOP		
KVP proportional		■			350 [5 077]	30 [7.9]	Electrical	CETOP		
KVM		■			350 [5 077]	40 [10.5]	Electrical	Bankable	Metric, Gas, UNF	

6/3

KV	■				210 [3 046]	6 [1.58]	Electrical		Metric, Gas	
----	---	--	--	--	-------------	----------	------------	--	-------------	--

8/3

KV		■			250 [3 626]	50 [13.2]	Electrical		Metric, Gas, UNF	
----	--	---	--	--	-------------	-----------	------------	--	------------------	--



Compact connecting components

To eliminate the use of pipe connections according your space and the evolution of the valving system.
The benefits are:

- Minimize the installing area and space.
- No expert skill is required to assemble and furthermore, a supplement and a change to the circuit can easily and quickly be carried out.
- No more problems such as oil leaks, vibration and noise resulting from pipes and tubes.

Compact mounting on manifold/subplate



		Manifold BP (max. 8 stations)	Subplates PP-KV (max.1 station)
Size NG	6	■	■
	10	■	■
	16		■
Max.pressure	bar [PSI]	350 [5 077]	350 [5 077]
Flow rate	l/min [GPM]	120 [31.6]	300 [79.0]
Connecting dimensions		CETOP	CETOP
Thread connections		Gas	Gas

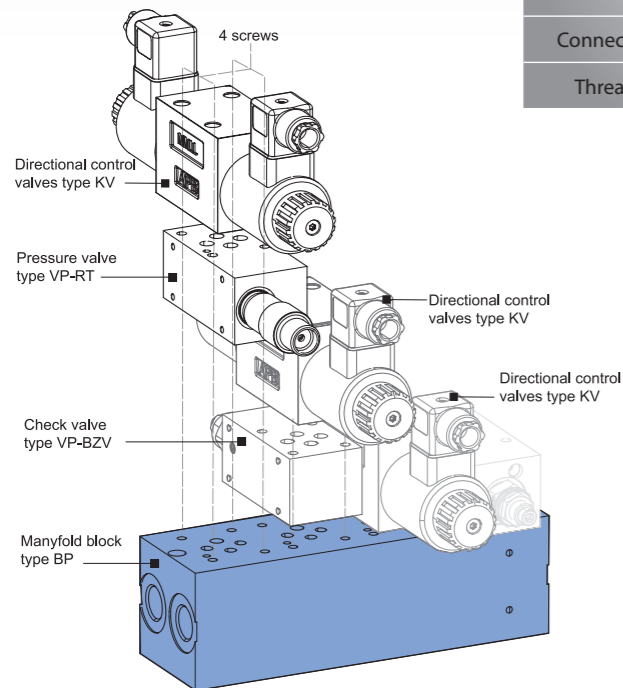

Bankable mounting for KVM directional control valve range

	Size	Operating pressure	Flow rate	Connecting dimensions*
	6	bar [PSI]	l/min [GPM]	
Inlet block OB-KVM	■	350 [5 077]	40 [10.5]	Into pipeline
Outlet block ZB-KVM	■	350 [5 077]	40 [10.5]	Into pipeline
Vertical Stacking STACK KVM	■	350 [5 077]	40 [10.5]	CETOP
Screw set SET-KVM	■			

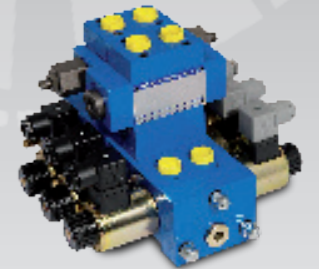

Vertical Stacking on KVM range thanks to STACK-KVM elements (= ①+②+③)

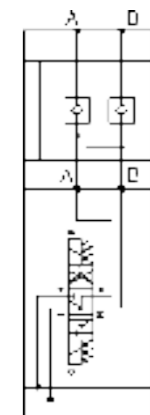
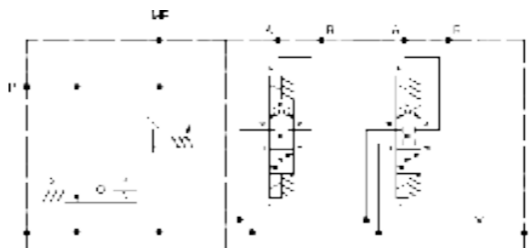
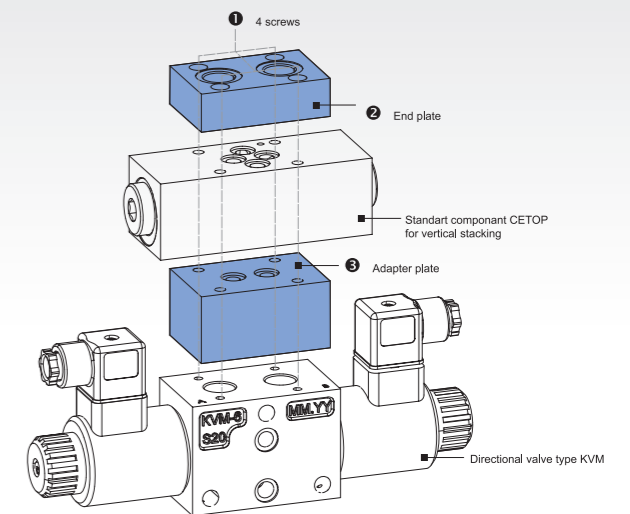
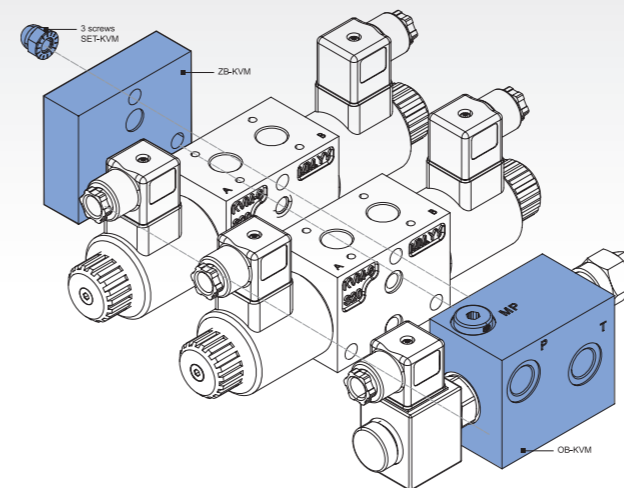

Brake Valves

- Max pressure: 210 bar [3000 PSI]
- Temperature from -20°C to 120°C [-4 to 248°F]
- Fluid: 10µm filtered mineral oil
- For single & dual circuit

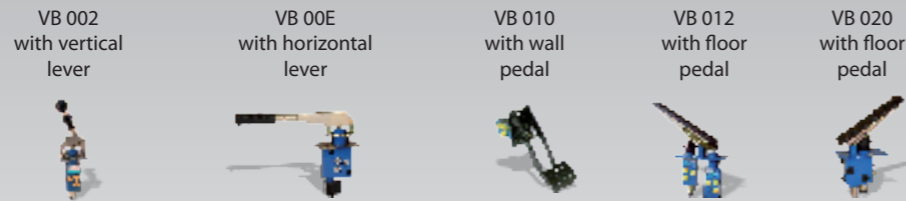

Brake actuators (Emergency, Parking & service Brake)

	Operating pressure		Brake type	Circuit	Valve type
	bar [PSI]				
VB 010	20 - 120 [290 - 1740]		Service brake	Single-circuit	Modulating
VB 020	30 - 120 [435 - 1740]			Dual-circuit	Modulating
VB 012	20 - 120 [290 - 1740]		Service brake with inching	Single-circuit	Combined
VB 022	30 - 120 [435 - 1740]			Dual-circuit	Combined
VB 002	10 - 120 [145 - 1740]		Emergency / Parking brake	Single-circuit	Reverse modulating
VB 00E	10 - 100 [145 - 1740]			Single-circuit	Reverse modulating

Power brake valves (Brake actuator + accumulator charging valve)

	Cut-in/ cut-out pressure range	Operating pressure	Flow rate	
			Auxiliary	Accumulator
	bar [PSI]	bar [PSI]	l/min [GPM]	l/min [GPM]
VB110 (single circuit)	110 / 130 [1595/1888]	30 - 120 [435 - 1740]	45 - 120 [11.9 - 31.7]	2.75 - 15 [0.73 - 3.96]
VB220 (dual circuit)	120 / 140 [1740/2031]			
VB -22E (dual circuit)	135 / 160 [1958/2321]			
	160 / 190 [2321/2756]			
	170 / 200 [2466/2901]			
	180 / 210 [2611/3046]			

VB 22E with floor pedal



Accumulator charging valves

	Cut-in/ cut-out pressure range	Flow rate	
		Auxiliary	Accumulator
	bar [PSI]	l/min [GPM]	l/min [GPM]
VB100 (single circuit)	110 / 130 [1595/1888]	45 - 120 [11.9 - 31.7]	2.75 - 15 [0.73 - 3.96]
VB200 (dual circuit)	120 / 140 [1740/2031]		
	135 / 160 [1958/2321]		
	160 / 190 [2321/2756]		
	170 / 200 [2466/2901]		
	180 / 210 [2611/3046]		

VB 100

VB 200



The underlying concept of Poclain Hydraulics braking systems can be adapted to handle your specific braking requirements.

VB brake valves are widely used for heavy applications with pneumatic tyres, high speed and requiring high flow to brakes (when master cylinder is inefficient).

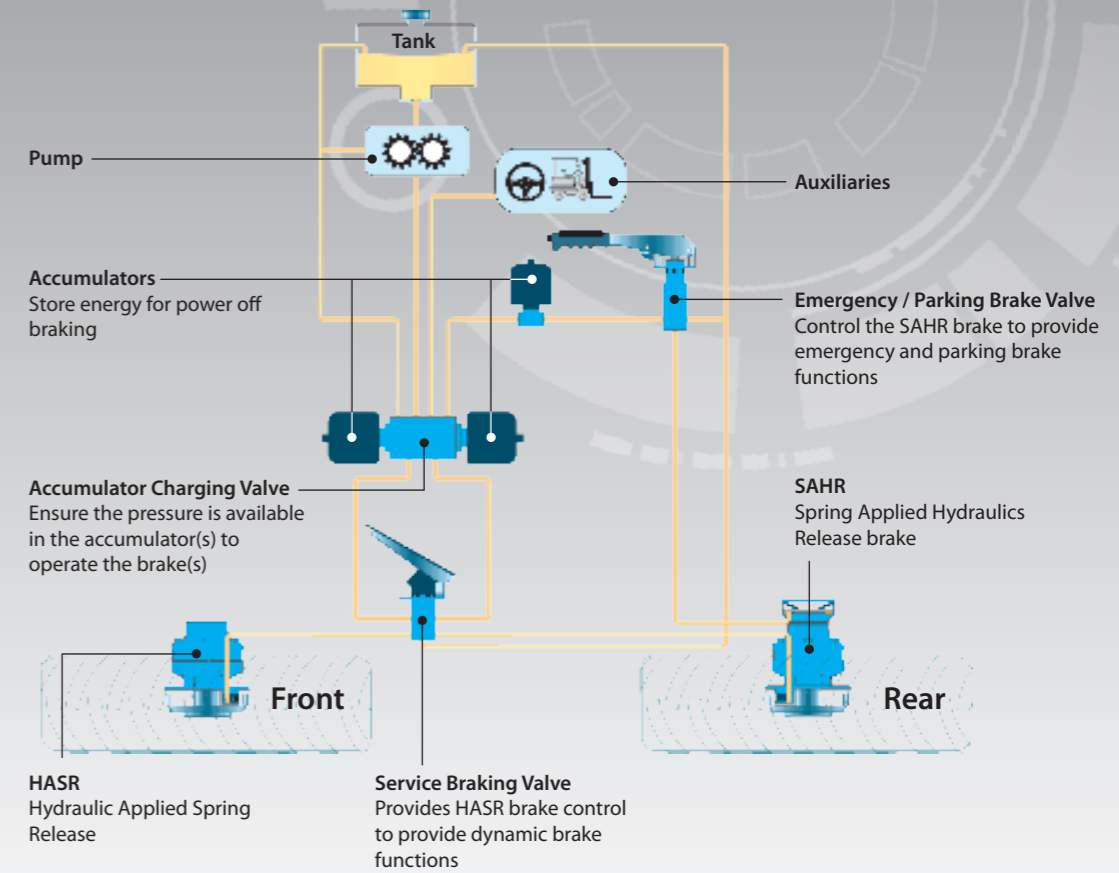

Tractors & trailers braking

Tractor

VB-0B0	Steering assist brake (Single circuit)	Max. operating pressure: 120 bar [1740 PSI] Max. service pressure: 60 bar [870 PSI]
VB-0D0	Steering assist brake (Dual circuit, improved response time)	Max. operating pressure: 120 bar [1740 PSI] Max. service pressure: 75 bar [1088 PSI]
VFR-200	Power brake valve	Max. flow auxiliaries: 120 l/min [32 GPM] accumulators: 15 l/min [4 GPM]

Trailer

VFR-0HX	Service brake hydraulically piloted	Flow brakes: 50 l/min [13 GPM] auxiliaries: 200 l/min [53 GPM]
VFR-0EX	Service brake electronically piloted	

VB-0B0 VB-0D0 VFR-0EX

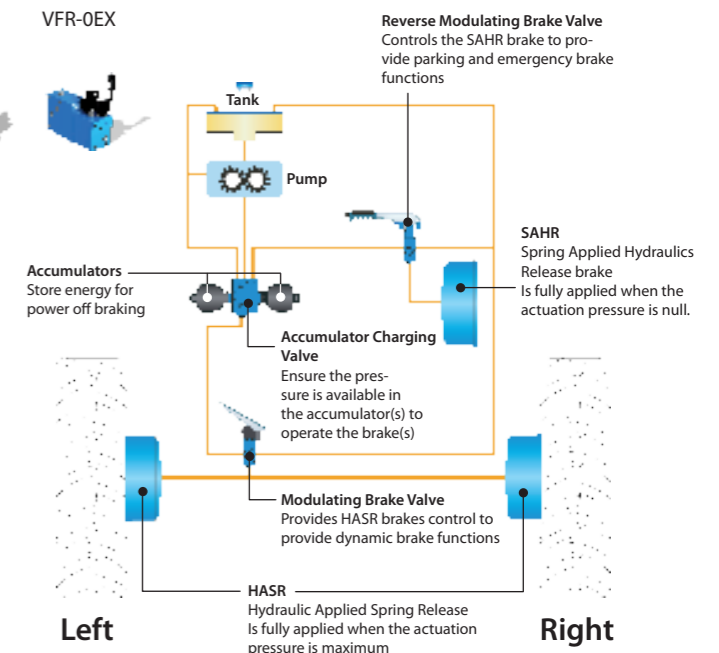

Anti-slipping systems Valves

To control wheel slippage during operating of hydrostatic self-propelled machinery in rough terrain conditions, Poclairn Hydraulics has developed **2 solutions** that offer an high vehicle gradeability by:

- Synchronization of wheel speed to avoid soil damage
- Optimized machine performance and stability
- Reduced fuel consumption
- Increased tire life (reduced wear)



1/ TwinLock™ valves

Twin Lock™ is a unique proactive hydraulic traction control, by providing flow division while automatically transferring torque to the wheels with the greatest ground adhesion. And since it reduces or eliminates the need for flow dividers, it dramatically reduces the heat generation and horsepower loss of conventional transmission systems.

	Max. pressure	Max.flow	Operation	Connecting dimensions*	Hydraulic schematics
	bar [PSI]	L/min [GPM]			
VDP	450 [6 526]	26 - 50 [7 - 13]	Hydraulic Mechanical	Metric	
New! PR-TL-SV	450 [6 526]	30 - 50 [7.9 - 13]	Hydraulic Electro-hydraulic	Metric	



Hydraulic Assistance Valves

Free wheeling valves

Cam lobe motor technology is ideally suited to assist drive requirements. The free-wheeling capability of Poclairn Hydraulics motors enables high performance when engaged yet will not induce a drag on the main transmission when disengaged. On motor, connects the ports A and R (or L and R on motor 1C) to tank and allows the pistons to return in cylinder-blocks and the motor to turn in freewheeling. It protects the motor from pressure spikes in the casing.



	Max. pressure	Max.flow	Operation	Connecting dimensions*	Hydraulic schematics	
	bar [PSI]	L/min [GPM]			With by-pass	Without by-pass
VDF H15	450 [6 526]	120 [31.6]	Electro-hydraulic 12-24 V DC	Metric		
VDF H25	450 [6 526]	300 [79]	Electro-hydraulic 12-24 V DC	Flange		

VDF H25 with remote pilot valve

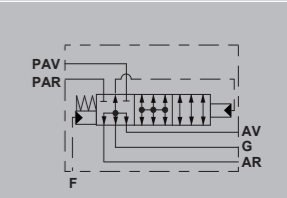

2/ SmartDrive™ Off Road valves

SmartDrive™ Off Road is an electronically managed traction control, which operates to restrict flow only when slippage is detected, by using normally wheel speed sensors and open proportional valves. Entirely programmable, the system easily accommodates varying motor displacements and vehicle steering geometry to offer optimal performance. SmartDrive™ Off Road can be installed by OEMs on production vehicles or offered as an after sale option (Poclairn Hydraulics motors just need to be "speed sensor ready").



	Voltage	Max. pressure	Max.flow	Connecting dimensions*	Hydraulic schematics
		bar [PSI]	L/min [GPM]		
VMA In-line model	12 V DC or 24 V DC	450 [6 526]	20 [5.2]	Metric	
VMA Flanged model			50 [13.2]		

Exchange Valves

Very compact valve to bleed hot oil from the low pressure side of a hydrostatic transmission circuit to be cooled, filtered or used as a source of oil for flushing other pump and motor case.

	Max. pressure	Exchange flow	Connecting dimensions*	Hydraulic schematics
		L/min [GPM]		
New! VE 10	450 [6 526]	10 [2.64]	in line Metric, Gas, UNF	
New! VE 30	450 [6 526]	30 [7.9]		
New! VE 60	450 [6 526]	60 [15.9]		

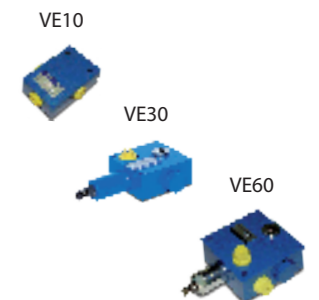

Electrical Components



	Size	Switching capacity	Operating pressure	Connecting dimensions	Electrical connector
Pressure switch TS, VP-TS	4		400 bar 5 082 PSI	Onto a subplate, into pipelines, vertical stacking, DIN 24340, ISO 4401	Plug-in connector
Control lever KRSS		5A / 12V		Inner thread, M10	FASTON A6, 3-0, 8, EN 61210
MR Solenoids for directional control valves	045/1	26 W	250 bar 3 626 PSI	M19x1 Into valve body	- Plug-in to ISO 4400 - AMP junior timer - Deutsch connector
	045	29 W		M27x1,5 - Into valve body	
	060	45 W			
Amplifier for proportional solenoids R59		1,8A 30W			Plug-in to ISO 4400

Customized block Valves

Our skills and tools to design the right solution for you:

- Strong R&D and engineering team with long term experiences in designing the solution to customer requests for wide range of applications
- Innovative compact design
- Short response time from request to offer, samples and series deliveries
- Advanced CAD/CAM tools for design and manufacturing
- Modern and efficient machinery and equipment for series production

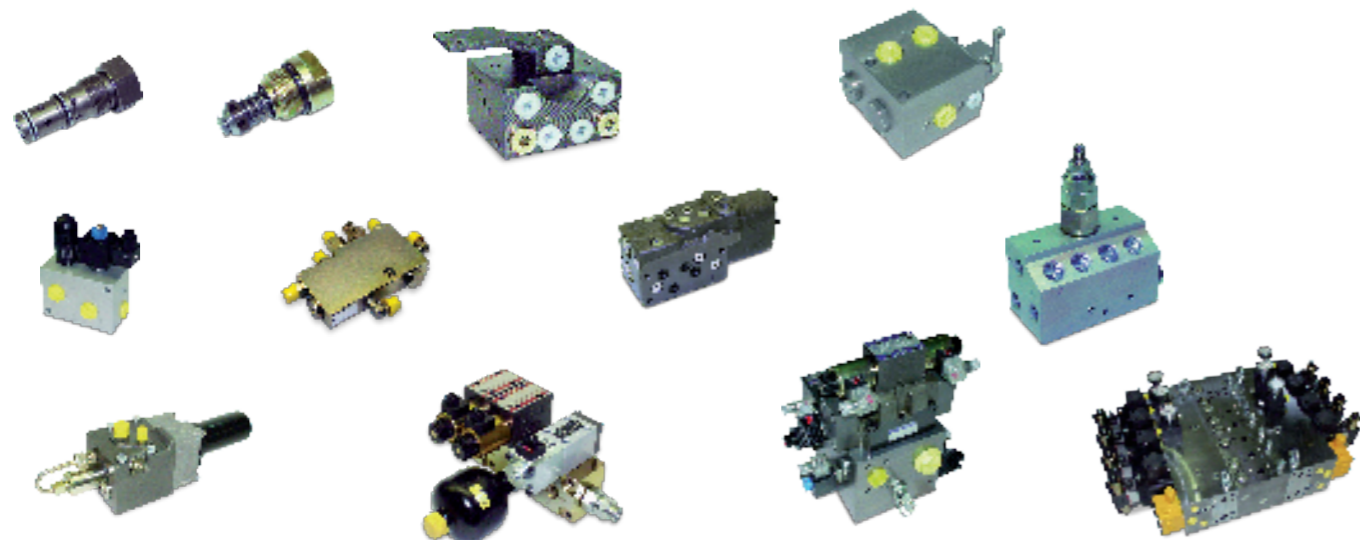

Poclain Hydraulics it is also Hydraulic Systems

Our world leading expertise enables us to provide customers with innovative solutions including hydraulic motors, pumps, valves and electronics that enhance vehicle performance, energy savings and safety.

Motors ■ Pumps ■ Valves ■ Electronics

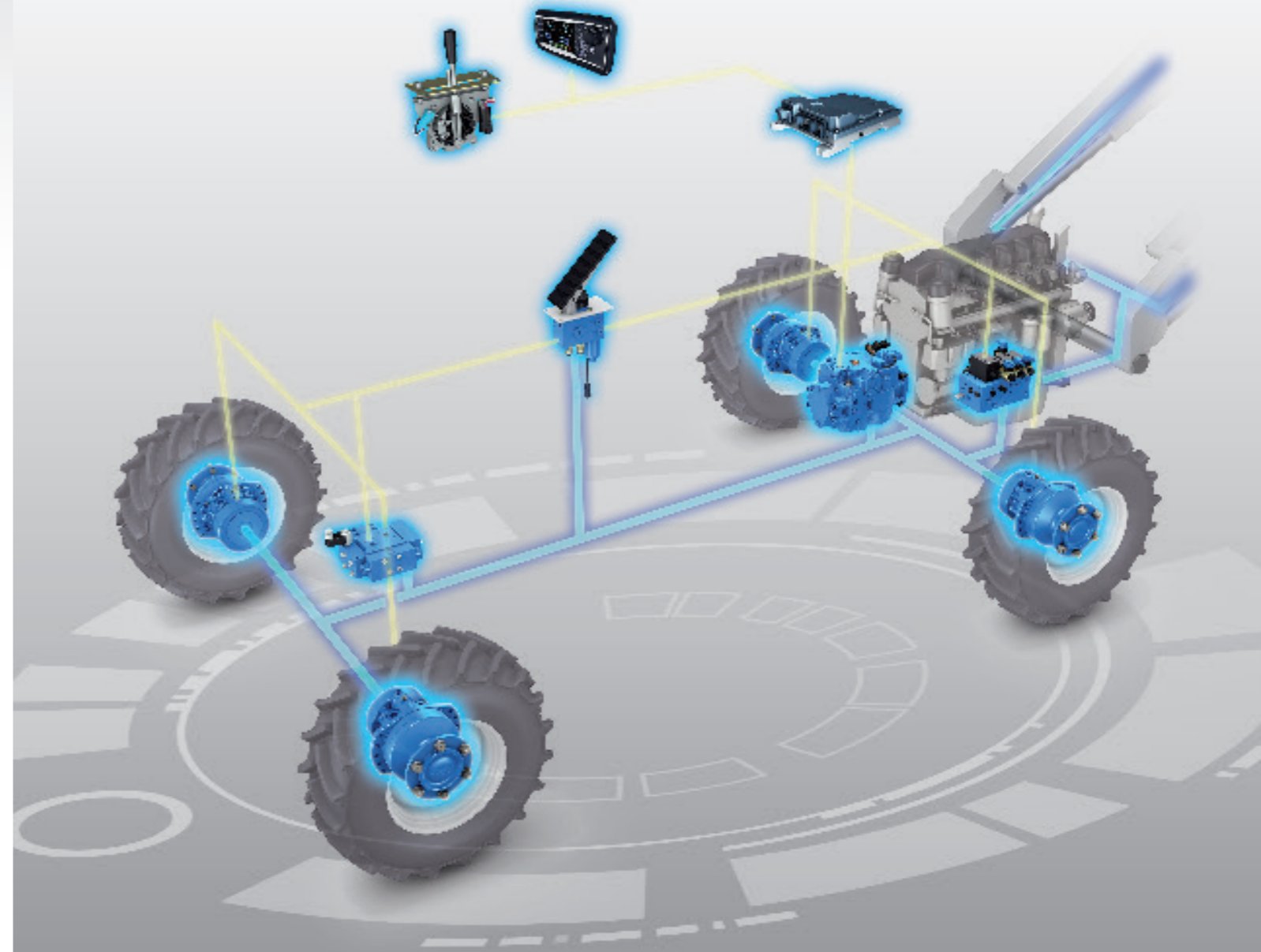

- Plants
- Sales subsidiary
- Logistic center
- ★ R&D center



- > 10 plants on 3 continents
- > More than 20 subsidiaries and remote offices
- > Over 150 distributors around the world
- > 2,000 people worldwide

www.poclain-hydraulics.com



Motors



Pumps



Valves

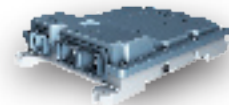

Electronics

