



Data Sheet

# PLUS+1<sup>®</sup> Controllers

## MC012-010 and 012



### Mobile Machine Management

MC012-010 and 012 controllers are elements of the flexible, powerful, expandable, and affordable PLUS+1 family of mobile machine management products. These devices are general-purpose controllers that are equally suited for use as members of a distributed machine control system, with intelligence in every node, or as stand-alone controllers.

### Product Highlights

Both controllers employ a Digital Signal Processor (DSP), providing the controllers with extremely fast single cycle processing speed, and 128K internal flash. The MC012-012 controller has an application key that enables the use of Danfoss developed GUIDE machine control solutions. The same GUIDE HWD file is used with all four controllers.

### Application Development

Users develop all four controller's applications with PLUS+1 GUIDE. This Microsoft® Windows® based development environment features a user-friendly, field proven, icon-based graphical programming tool, application downloader, and service/diagnostic tool.

### Features

- User-programmable with PLUS+1 GUIDE (Graphical User Integrated Development Environment)
- 32 bit fixed-point DSP running at 150 MHz
  - 12 bit analog-to-digital converter
  - 16 bit timers/counters
- 12 pin Deutsch® DTM connector
- 4 inputs
  - (3) universal (DIN/AIN/FreqIN) that are user-defined as either:
    - Analog:* with configurable ranges 0 to 5.25 Vdc (with over range protection) or 0 to 36 Vdc;
    - Digital:* pull up (5 Vdc), pull down (0 Vdc) or pull to center (2.5 Vdc);
    - Frequency (timing):* 1 Hz to 10 kHz
  - (1) fixed range analog (AIN/CAN shield) 0 to 5.25 Vdc or CAN shield pin
- 2 outputs
  - (2) universal (PWMOUT/DOUT/PVGOUT) that are user-defined as either:
    - Digital:* (3 A), configurable as source or sink;
    - PWM:* (30 to 4000 Hz), configurable as open or closed loop with current control;
    - Analog voltage:* open loop PWM at 4000 Hz
  - Any PWMOUT/DOUT/PVGOUT can be used to provide reference power to one PVG valve
- 9 to 36 Vdc power supply, monitored internally
- 1 CAN 2.0 B port, the fixed range analog input can be configured as the shield pin
- Power supply for external sensors rated at 5 Vdc to 100 mA and regulated internally
- 2 LEDs under user control
- 3 mounting alternatives: stack, end, or side
- The MC012-012 controller contains the application key required to run Danfoss developed machine control application software
- CE compliant

Dimensions and Pin Assignments

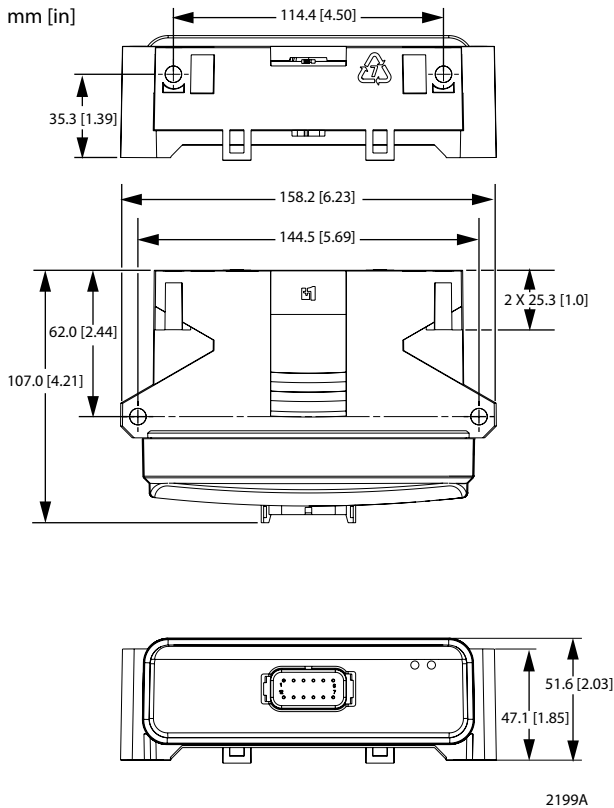

12 Pin Connector

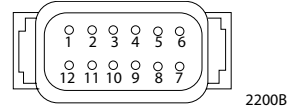

Connector

Pin	Controller function
C1-P1	Power ground -
C1-P2	Power supply +
C1-P3	CAN +
C1-P4	CAN -
C1-P5	AIN/CAN shield
C1-P6	5 Vdc sensor power +
C1-P7	Sensor power ground -
C1-P8	DIN/AIN/FreqIN
C1-P9	DIN/AIN/FreqIN
C1-P10	DIN/AIN/FreqIN
C1-P11	PWMOUT/DOUT/PVGOUT
C1-P12	PWMOUT/DOUT/PVGOUT

Use care when wiring mating connector. Above pinouts are for device pins.

**Caution**

This device is not field serviceable. Opening the device housing will void the warranty.

Specifications

Supply voltage	9 to 36 Vdc
Operating temperature (ambient)	-40°C to 70°C [-40°F to 158°F]
Storage temperature	-40°C to 85°C [-40°F to 185°F]
Programming temperature	0°C to 70°C °F to 158°F]
IP rating (with mating connector attached)	IP 67
EMI/ RFI rating	100 V/M
Weight	0.40 kg [0.88 lb]
Vibration	IEC 60068-2-64
Shock	IEC 60068-2-27 test Ea
Maximum current, sourcing	8 A
Maximum current, sinking	8 A

Ordering Information

MC012-010 part number	10103773
MC012-012 part number	11013721

Related product	Danfoss part numbers	
CG150 CAN/USB Gateway	10104136	
Deutsch® mating connector bag assembly	10102025 (16 to 20 AWG)	10100944 (20 to 24 AWG)
PLUS+1 GUIDE single user license	10101000	

Danfoss comprehensive technical information PLUS+1 Controller Family Technical Information, 520L0719 and MC012-010 and 012 Application Program Interface (API) Document are on line at: [www.danfoss.com](http://www.danfoss.com) and/or embedded in product HWD file.

**Danfoss Power Solutions (US) Company**  
2800 East 13th Street  
Ames, IA 50010, USA  
Phone: +1 515 239 6000

**Danfoss Power Solutions GmbH & Co. OHG**  
Krokamp 35  
D-24539 Neumünster, Germany  
Phone: +49 4321 871 0

**Danfoss Power Solutions ApS**  
Nordborgvej 81  
DK-6430 Nordborg, Denmark  
Phone: +45 7488 2222

**Danfoss Power Solutions Trading (Shanghai) Co. Ltd.**  
Building #22, No. 1000 Jin Hai Rd  
Jin Qiao, Pudong New District  
Shanghai, China 201206  
Phone: +86 21 3418 5200

Danfoss can accept no responsibility for possible errors in catalogues, brochures and other printed material. Danfoss reserves the right to alter its products without notice. This also applies to products already on order provided that such alterations can be made without changes being necessary in specifications already agreed. All trademarks in this material are property of the respective companies. Danfoss and the Danfoss logotype are trademarks of Danfoss A/S. All rights reserved.