

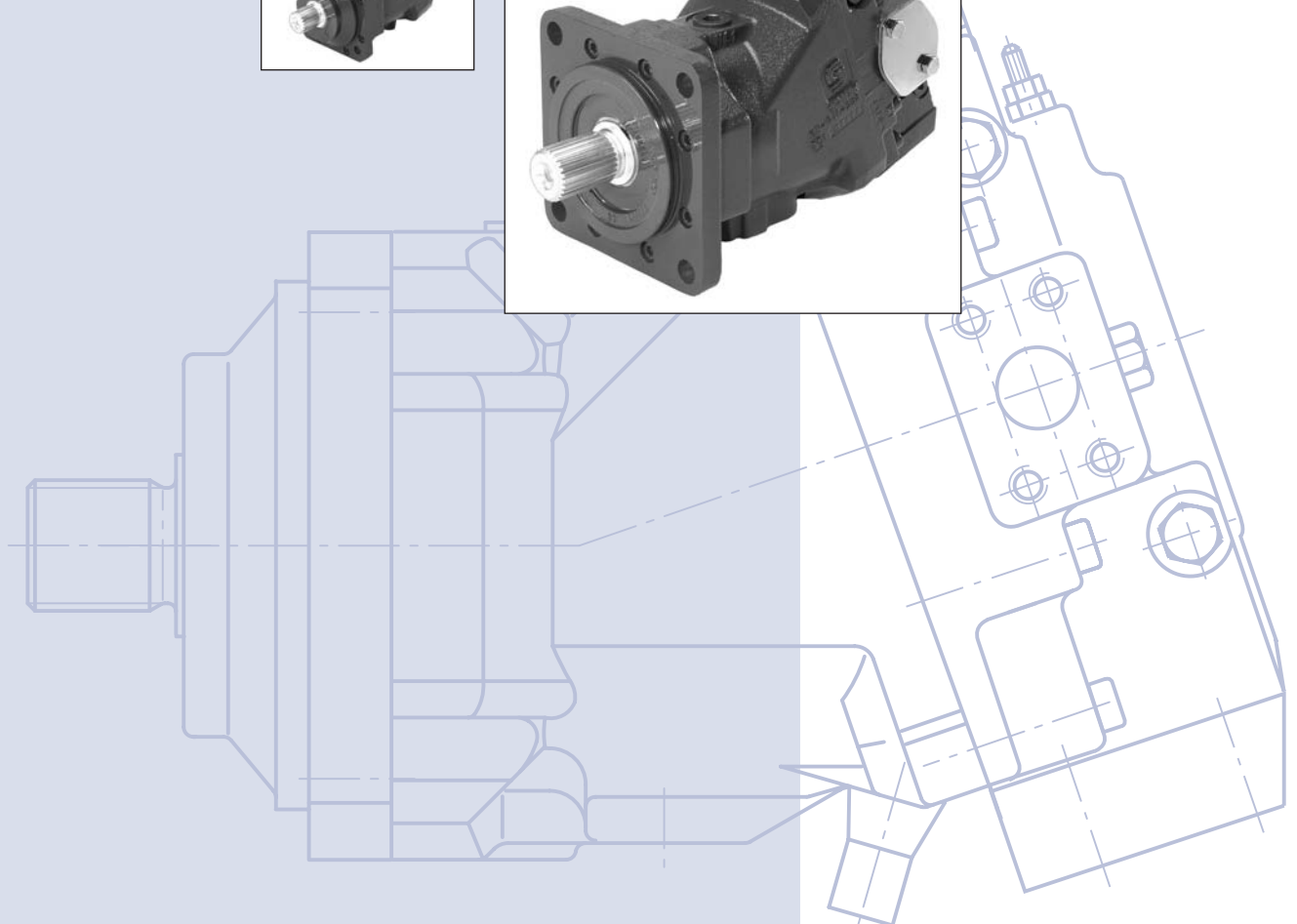

Series 51
Series 51-1
Bent Axis Variable
Displacement
Motors

Technical
Information

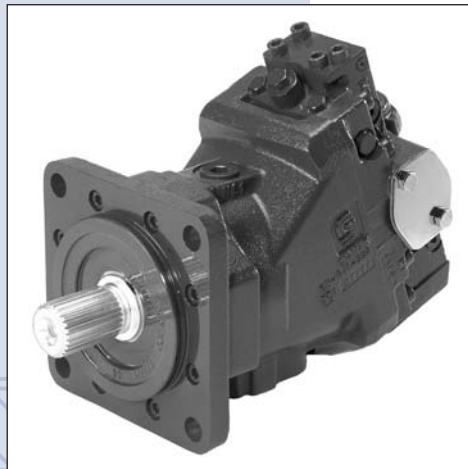

GENERAL DESCRIPTION

Series 51 and 51-1 variable displacement motors are bent axis design units, incorporating spherical pistons.

These motors are designed primarily to be combined with other products in closed circuit systems to transfer and control hydraulic power. Series 51 and 51-1 motors have a large maximum / minimum displacement ratio (5:1) and high output speed capabilities. SAE, cartridge, and DIN flange configurations are available.

A complete family of controls and regulators is available to fulfill the requirements of a wide range of applications.

Motors normally start at maximum displacement. This provides maximum starting torque for high acceleration.

The controls may utilize internally supplied servo pressure. They may be overridden by a pressure compensator which functions when the motor is operating in motor and pump modes. A defeat option is available to disable the pressure compensator override when the motor is running in pump mode.

The pressure compensator option features a low pressure rise (short ramp) to ensure optimal power utilization throughout the entire displacement range of the motor. The pressure compensator is also available as a stand-alone regulator.

- The series 51 and 51-1 motors – Advanced technology today
- The most technically advanced hydraulic units in the industry
- SAE, cartridge, and DIN flange motors
- Cartridge motors designed for direct installation in compact planetary drives
- Large displacement ratio (5:1)
- Complete family of control systems
- Proven reliability and performance
- Optimum product configurations
- Compact, lightweight

© 2009, Sauer-Danfoss

Sauer-Danfoss can accept no responsibility for possible errors in catalogues, brochures and other printed material. Sauer-Danfoss reserves the right to alter its products without prior notice. This also applies to products already ordered provided that such alterations can be made without subsequent changes being necessary in specifications already agreed. All trademarks in this material are properties of the respective companies. Sauer-Danfoss and the Sauer-Danfoss logotype are trademarks of the Sauer-Danfoss Group. All rights reserved.

Front page: F300550, F300542, F300541, F300549, P001196-2

CONTENTS

General Description 2

Sectional View..... 6

 Series 51-1, Two-Position Control 6

 Series 51, Proportional Control..... 7

System Circuit Description..... 8

 Pictorial Diagram..... 8

 System Circuit Diagram..... 8

Technical Specifications 10

 General specifications 10

 Specific Data 10

 Fluid Specifications..... 11

 Determination of Nominal Motor Sizes 12

General Technical Specifications..... 13

 Case Pressure 13

 Speed Range..... 13

 Pressure Limits 14

 Loop Flushing 14

 Minimum Displacement Limiter 16

 Hydraulic Fluids..... 16

 Temperature and Viscosity 16

 Fluid and Filtration..... 17

 Independent Braking System 18

 Reservoir..... 18

 Motor Bearing Life 19

 External Shaft Loads..... 20

 External Shaft Loads Orientation..... 20

 Allowable External Shaft Load, when Shaft Load Distance is different from Standard..... 22

 Efficiency Graphs and Maps 23

 Speed Sensor 25

Typical Control and Regulator Applications 26

Controls Circuit Diagram – Nomenclature – Description..... 28

 Hydraulic Two-Position Control – Option N1NN for 51-1 – Frame Size 060, 080, 110 28

 Hydraulic Two-Position Control – Option HZB1 for 51 – Frame Size 160, 250 29

 Pressure Compensator Control – Options TA** for 51-1 – Frame Size 060, 080, 110 30

 Pressure Compensator Control – Options TA** for 51 – Frame Size 160, 250 33

 Hydraulic Two-Position Control – Options TH** for 51-1 – Frame Size 060, 080, 110..... 35

 Hydraulic Two-Position Control – Options TH** for 51 – Frame Size 160, 250 38

 Electrohydraulic Two-Position Control – Options E1B1, E2B1, E7B1 for 51-1
 Frame Size 060, 080, 110 40

 Electrohydraulic Two-Position Control – Options E1A5, E2A5 for 51 – Frame Size 160, 250..... 42

 Electrohydraulic Two-Position Control – Options F1B1, F2B1 for 51-1
 Frame Size 060, 080, 110 43

 Electrohydraulic Two-Position Control – Options F1A5, F2A5 for 51 – Frame Size 160, 250..... 45

 Electrohydraulic Two-Position Control – Options T1**, T2**, T7** for 51-1
 Frame Size 060, 080, 110 46

 Electrohydraulic Two-Position Control – Options T1**, T2** for 51 – Frame Size 160, 250 49

 Electrohydraulic Proportional Control – Options EP**, EQ** for 51
 Frame Size 060, 080, 110, 160, 250 52

 Electrohydraulic Proportional Control – Options L1B1, L2B1, L7B1 for 51
 Frame Size 060, 080, 110, 160, 250 55

 Electrohydraulic Proportional Control – Options D7M1, D8M1 for 51
 Frame Size 060, 080, 110, 160, 250 56

CONTENTS
(continued)

Hydraulic Proportional Control – Options HS** for 51, Frame Size 060, 080, 110, 160, 250.....	58
Hydraulic Proportional Control – Option HZB1 for 51, Frame Size 060, 080, 110, 160, 250.....	60
General Dimensions – Frame Size 060.....	62
SAE Flange Design per ISO 3019/1	62
51V060-1 Two Position Control, N1NN	62
51V060 Proportional and Two-Position Control, HZB1	63
Shaft Options – 51V060-1 and 51V060	64
DIN Flange Design per ISO 3019/2.....	65
51D060-1 Two Position Control, N1NN.....	65
51D060 Proportional and Two-Position Control, HZB1	66
Shaft Options – 51D060-1 and 51D060	67
Cartridge Flange.....	68
51C060-1 Two Position Control, N1NN	68
51C060 Proportional and Two-Position Control, HZB1	69
Shaft Options – 51C060-1 and 51C060.....	70
General Dimensions – Frame Size 080.....	71
SAE Flange Design per ISO 3019/1	71
51V080-1 Two Position Control, N1NN	71
51V080 Proportional and Two-Position Control, HZB1	72
Shaft Options – 51V080-1 and 51V080	73
DIN Flange Design per ISO 3019/2.....	74
51D080-1 Two Position Control, N1NN	74
51D080 Proportional and Two-Position Control, HZB1	75
Shaft Options – 51D080-1 and 51D080	76
Cartridge Flange.....	77
51C080-1 Two Position Control, N1NN	77
51C080 Proportional and Two-Position Control, HZB1.....	78
Shaft Options – 51C080-1 and 51C080.....	79
General Dimensions – Frame Size 110.....	80
SAE Flange Design per ISO 3019/1	80
51V110-1 Two Position Control, N1NN	80
51V110 Proportional and Two-Position Control, HZB1	81
Shaft Options – 51V110-1 and 51V110	82
DIN Flange Design per ISO 3019/2.....	83
51D110-1 Two Position Control, N1NN.....	83
51D110 Proportional and Two-Position Control, HZB1	84
Shaft Options – 51D110-1 and 51D110	85
Cartridge Flange.....	86
51C110-1 Two Position Control, N1NN	86
51C110 Proportional and Two-Position Control, HZB1.....	87
Shaft Options – 51C110-1 and 51C110.....	88
General Dimensions – Frame Size 160	90
SAE Flange Design per ISO 3019/1	90
51V160 Proportional and Two-Position Control, HZB1	90
Shaft Options – 51V160.....	91
DIN Flange Design per ISO 3019/2.....	92
51D160 Proportional and Two-Position Control, HZB1	92
Shaft Options – 51D160	93
Cartridge Flange.....	94
51C160 Proportional and Two-Position Control, HZB1.....	94
Shaft Options – 51C160.....	95

CONTENTS
(continued)

General Dimensions – Frame Size 250.....	96
SAE Flange Design per ISO 3019/1	96
51V250 Proportional and Two-Position Control, HZB1	96
Shaft Options – 51V250.....	97
Dimension – Controls.....	98
Pressure Compensator Control – Options TA** for 51-1 – Frame Size 060,080, 110	98
Pressure Compensator Control – Options TA** for 51 – Frame Size 160, 250	99
Hydraulic Two-Position Control – Options TH** for 51-1 – Frame Size 060,080, 110	100
Hydraulic Two-Position Control – Options TH** for 51 – Frame Size 160,250	101
Electrohydraulic Two-Position Control – Options E1B1, E2B1, E7B1, F1B1, F2B1 for 51-1 Frame Size 060,080, 110	102
Electrohydraulic Two-Position Control – Options E1A5, E2A5, F1A5, F2A5 for 51 Frame Size 160, 250	103
Electrohydraulic Two-Position Control – Options T1**, T2**, T7** for 51-1 Frame Size 060,080, 110	104
Electrohydraulic Two-Position Control – Options T1C2, T2C2 for 51 – Frame Size 160, 250	105
Electrohydraulic Proportional Control – Options EPA1, EQA1 for 51 Frame Size 060,080, 110, 160, 250	106
Electrohydraulic Proportional Control – Options L1B1, L2B1, L7B1 for 51 Frame Size 060,080, 110, 160, 250.....	107
Electrohydraulic Proportional Control – Options D7M1, D8M1 for 51 Frame Size 060,080, 110	108
Electrohydraulic Proportional Control – Options D7M1, D8M1 for 51 – Frame Size 160, 250.....	109
Hydraulic Proportional Control – Options HSA* for 51 – Frame Size 060,080, 110, 160, 250.....	110
Hydraulic Proportional Control – Option HZB1 for 51 – Frame Size 060,080, 110, 160, 250	111

**SERIES 51-1,
 TWO-POSITION
 CONTROL**

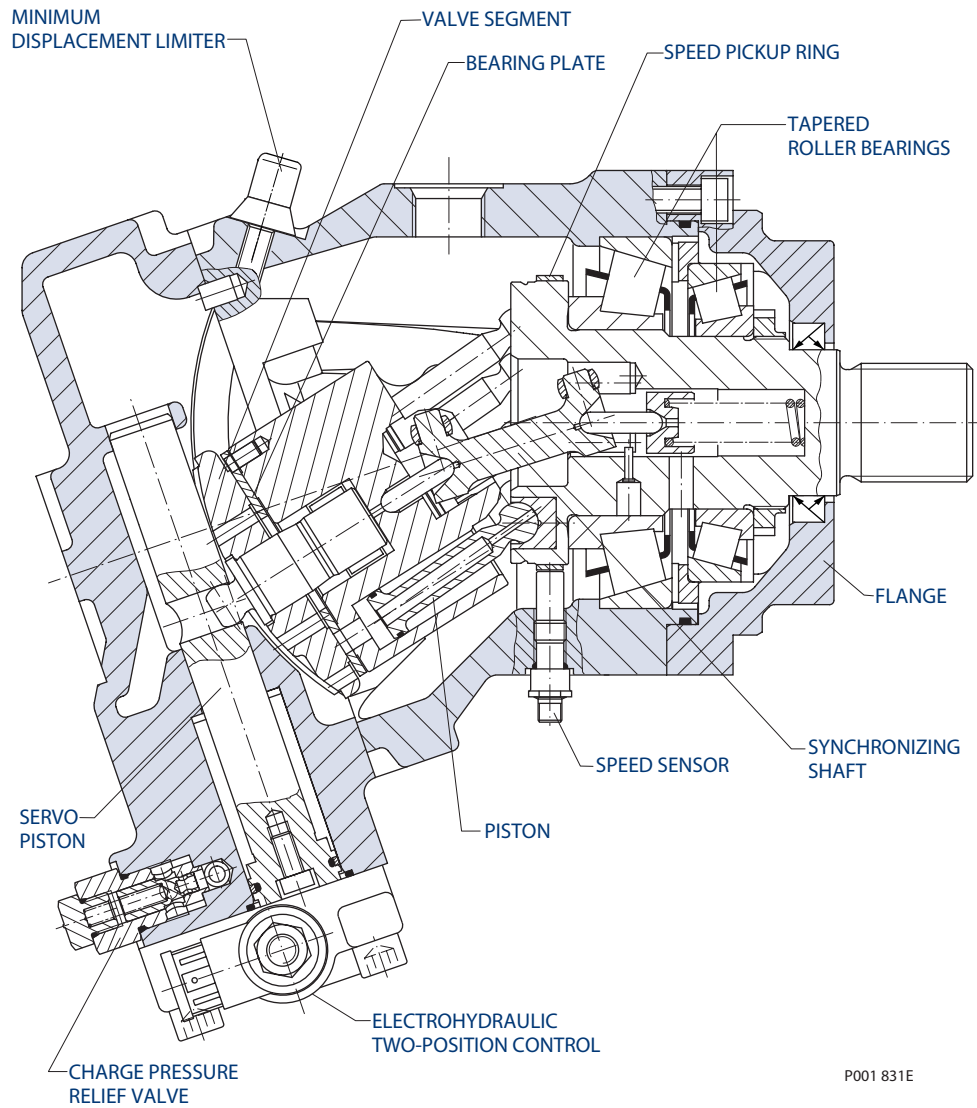

P001 831E

Name Plate

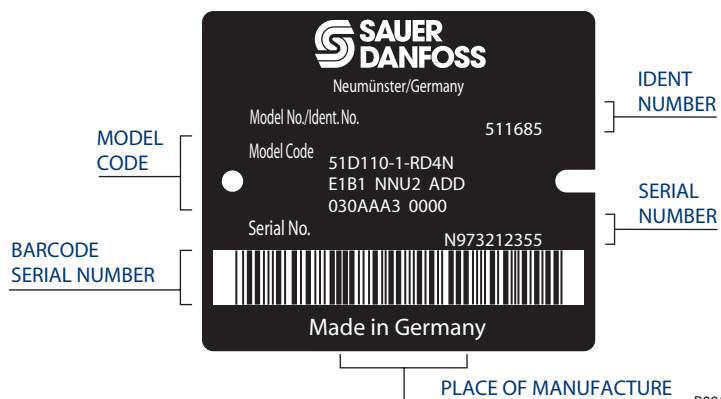

P001 832E

**SERIES 51,
 PROPORTIONAL
 CONTROL**

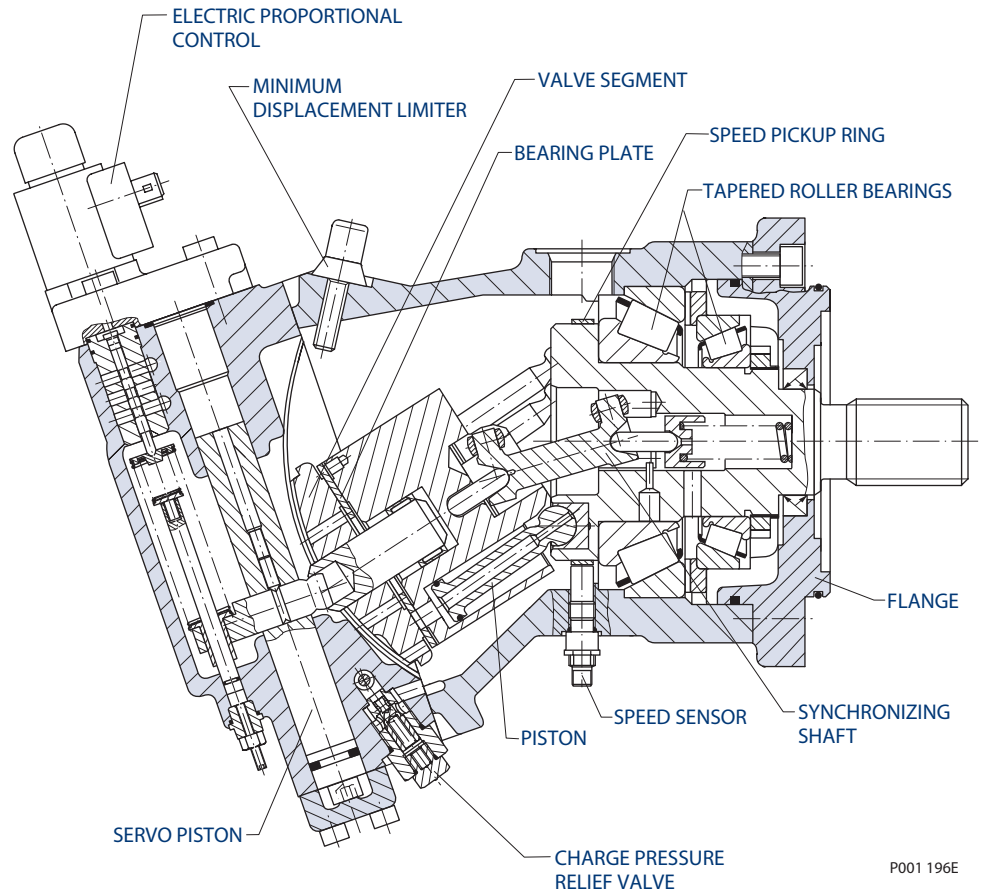

Name Plate

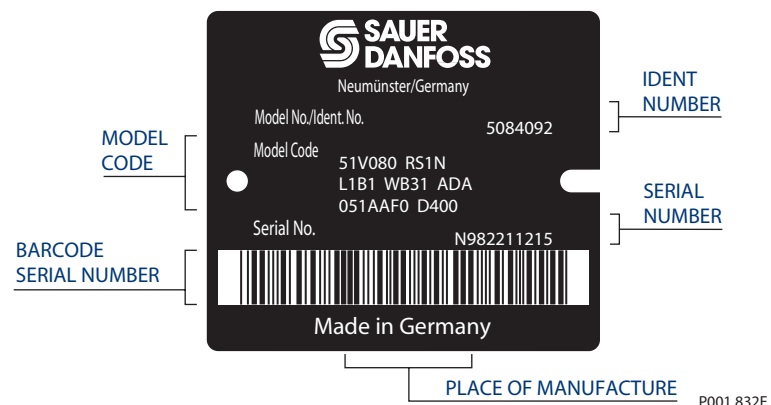

PICTORIAL DIAGRAM

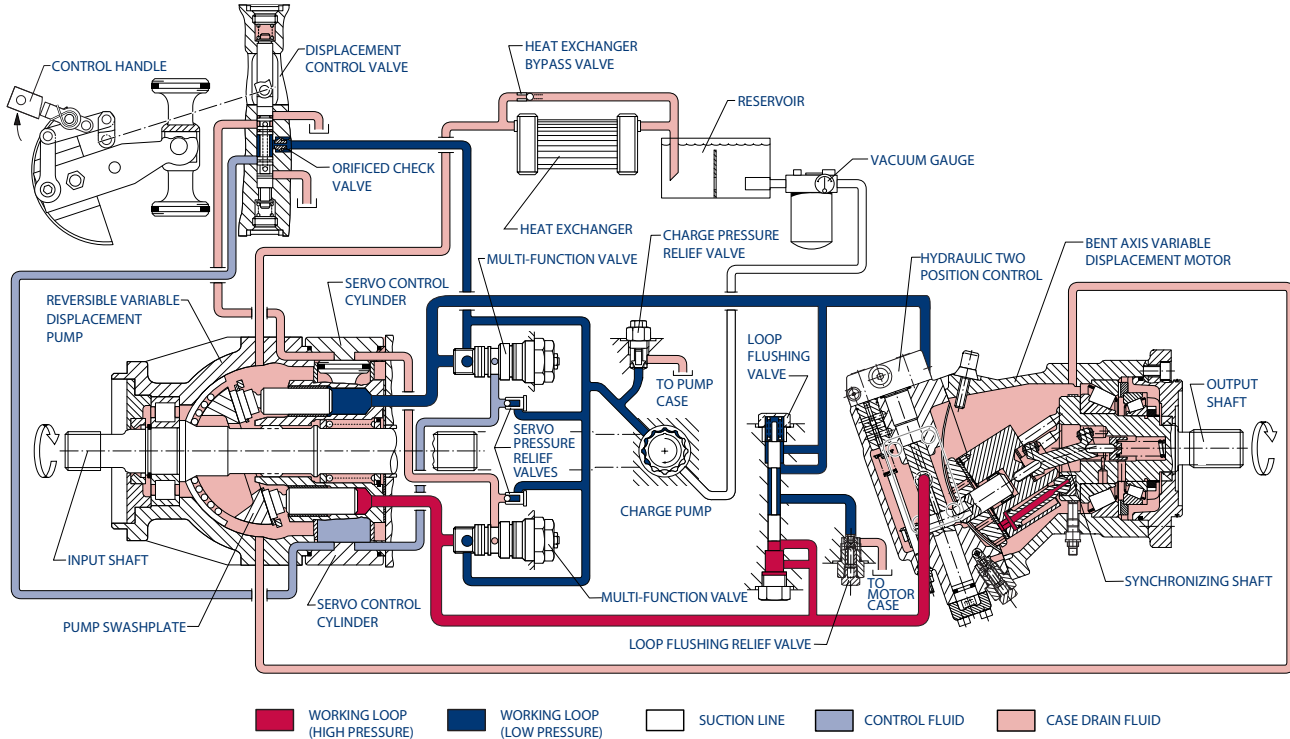

P001 175E

SYSTEM CIRCUIT DIAGRAM

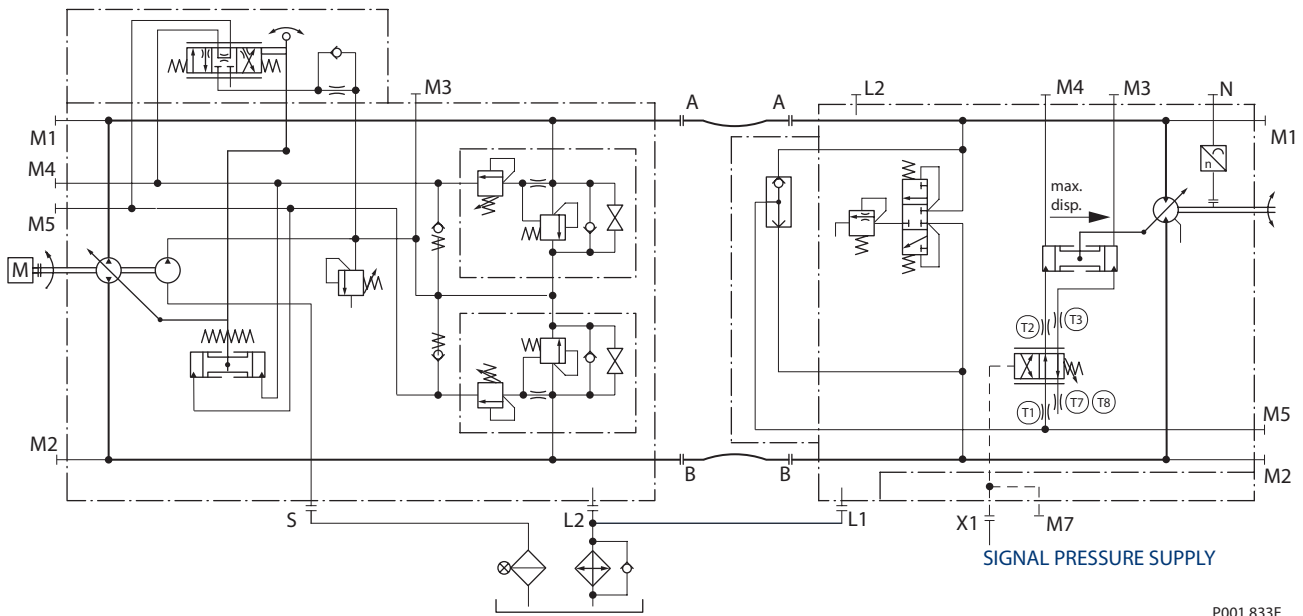

P001 833E

Above schematics show the function of a hydrostatic transmission using a Series 90 Axial Piston Variable Displacement Pump with manual displacement control (MA) and a Series 51 Bent Axis Variable Displacement Motor with hydraulic two-position control (HZ).



Series 51 and 51-1 Bent Axis Variable Displacement Motors
Technical Information
Notes

GENERAL SPECIFICATIONS

Most specifications for bent axis variable displacement motors are listed on these pages. For definitions of the various specifications, see the related pages in this publication. Not all hardware options are available for all configurations; consult the series 51 and 51-1 model code supplement or price book for more information.

General Specifications	
Motor type	Axial piston motor with variable displacement bent axis design.
Direction of rotation	Clockwise and counter-clockwise (bi-directional).
Installation position	Discretionary, the housing must always be filled with hydraulic fluid.
Other system requirements	Independent braking system, circuit overpressure protection, suitable reservoir.

SPECIFIC DATA

Specific Data							
			Frame size				
			060	080	110	160	250
	Dimension						
Displacement maximum	$V_{g_{max}}$	cm ³ [in ³]	60.0 [3.66]	80.7 [4.92]	109.9 [6.71]	160.9 [9.82]	250.0 [15.26]
Displacement minimum	$V_{g_{min}}$	cm ³ [in ³]	12.0 [0.73]	16.1 [0.98]	22.0 [1.34]	32.2 [1.96]	50.0 [3.05]
Rated flow	Q	l/min [US gal/min]	216 [57]	250 [66]	308 [81]	402 [106]	550 [145]
Maximum flow	Q_{max}	l/min [US gal/min]	264 [70]	323 [85]	396 [105]	515 [136]	675 [178]
Maximum corner power	P corner max.	kW [hp]	336 [450]	403 [540]	492 [660]	644 [864]	850 [1140]
Weight (approx.)	m	kg [lb]	28 [62]	32 [71]	44 [97]	56 [123]	86 [190]
Mass moment of inertia of the internal rotating parts	J	kgm ² [lb·ft ²]	0.0046 [0.1092]	0.0071 [0.1685]	0.0128 [0.3037]	0.0234 [0.5553]	0.0480 [1.1580]
Type of mounting	Four (4) bolt flange, SAE or DIN-flange configuration. Two (2) bolt flange cartridge motor configuration.						
Pipe connections	Main pressure ports: SAE-flange. Remaining ports: SAE straight thread O-ring boss.						
Controls	N1, HZ, E1, E2, E7, F1, F2, T1, T2, TA, TH, EP, EQ, L1, L2, L7, D7, D8, HS						
Displacement limiter	All Series 51 motors incorporate mechanical minimum and maximum displacement limiters.						
Shaft configuration	Splined ANSI or DIN shaft.						

SPECIFIC DATA (continued)

Case Pressure

	bar	[psi]
Rated pressure	3	[44.0]
Maximum pressure (cold start)	5	[73.0]
Minimum pressure (at rated speed)	1	[14.5]

System Pressure Range, Input

	bar	[psid]
Maximum delta pressure	480	[7000]
Minimum low pressure	10	[145]
Maximum pressure	510	[7400]

Speed Limits

		min ⁻¹ (rpm)				
Frame size		060	080	110	160	250
Rated speed	at max. disp.	3600	3100	2800	2500	2200
	at min. disp.	5600	5000	4500	4000	3400
Maximum speed ¹⁾	at max. disp.	4400	4000	3600	3200	2700
	at min. disp.	7000	6250	5600	5000	4250

¹⁾ Contact your Sauer-Danfoss representative for max. speed at displacements between max. and min. displacement.

Theoretical Torque

Frame size		060	080	110	160	250
At maximum displacement	Nm/bar	0.95	1.28	1.75	2.56	3.98
	[lbf·in/1000 psi]	[583]	[784]	[1067]	[1563]	[2428]
At minimum displacement	Nm/bar	0.19	0.26	0.35	0.51	0.80
	[lbf·in/1000 psi]	[117]	[156]	[214]	[313]	[486]

FLUID SPECIFICATIONS

Temperature Range ¹⁾

	°C	[°F]	
Minimum	-40	[-40]	intermittent, cold start
Rated	104	[220]	
Maximum	115	[240]	intermittent

¹⁾ At the hottest point, normally the case drain port.

Viscosity

	mm ² /s	[SUS]	
Minimum	7	[49]	intermittent
Recommended operating range	12-80	[70-370]	
Maximum	1600	[7500]	intermittent cold start

Cleanliness Level and β_x -Ratio

Required Fluid Cleanliness Level	ISO 4406 Class 22-18-13
Recommended β_x -Ratio for Suction Filtration	$\beta_{35-45} = 75$ ($\beta_{10} \geq 2$)
Recommended β_x -Ratio for Charge Pressure Filtration	$\beta_{15-20} = 75$ ($\beta_{10} \geq 10$)
Recommended Inlet Screen Size for Charge Pressure Filtration	100 μ m-125 μ m

**DETERMINATION OF
 NOMINAL MOTOR SIZES**

Metric System

Input flow: $Q_e = \frac{Vg \cdot n}{1000 \cdot \eta_v}$

Output torque: $M_e = \frac{Vg \cdot \Delta p \cdot \eta_{mh}}{20 \cdot \pi}$

Output power: $P_e = \frac{M_e \cdot n}{9550} = \frac{Q_e \cdot \Delta p \cdot \eta_t}{600}$ kW

Speed: $n = \frac{Q_e \cdot 1000 \cdot \eta_v}{Vg}$

Vg = Motor displacement per rev. cm^3

Δp = $p_{HD} - p_{ND}$ bar

η_v = Motor volumetric efficiency

η_{mh} = Motor mechanical-hydraulic (Torque) efficiency

η_t = Motor total (overall) efficiency

p_{HD} = High pressure bar

p_{ND} = Low pressure bar

Inch System

l/min $Q_e = \frac{Vg \cdot n}{231 \cdot \eta_v}$ [US gal/min]

Nm $M_e = \frac{Vg \cdot \Delta p \cdot \eta_{mh}}{2 \cdot \pi}$ [lbf-in]

$P_e = \frac{Vg \cdot n \cdot \Delta p \cdot \eta_t}{396\,000}$ [hp]

$n = \frac{Q_e \cdot 231 \cdot \eta_v}{Vg}$ min^{-1} (rpm)

cm^3 [in³]

bar [psid]

bar [psid]

bar [psid]

CASE PRESSURE

Under normal operating conditions, case pressure must not exceed the **rated pressure**. Momentary case pressure exceeding this rating is acceptable under cold start conditions, but still must stay below the **maximum pressure** rating. The **minimum pressure** provides proper lubrication at high speeds. Operation with case pressure in excess of these limits may result in external leakage due to damage to seals, gaskets, and/or housings.

Case Pressure

	bar	[psi]
Rated pressure	3	[44.0]
Maximum pressure (cold start)	5	[73.0]
Minimum pressure (at rated speed)	1	[14.5]

SPEED RANGE

Rated Speed is the speed limit recommended at full power condition and is the highest value at which normal life can be expected.

Maximum Speed is the highest operating speed permitted and cannot be exceeded without reduction in the life of the product or risking immediate failure and loss of driveline power (which may create a safety hazard). In the range between rated and maximum speed please contact your Sauer-Danfoss representative.

Warning: The loss of hydrostatic drive line power in any mode of operation (e.g., forward, reverse, or “neutral” mode) may cause the loss of hydrostatic braking capacity. A braking system, redundant to the hydrostatic transmission must, therefore, be provided which is adequate to stop and hold the system should the condition develop.

		Speed Limits				
		min ⁻¹ (rpm)				
Frame size		060	080	110	160	250
Rated speed	at max. disp.	3600	3100	2800	2500	2200
	at min. disp.	5600	5000	4500	4000	3400
Maximum speed ¹⁾	at max. disp.	4400	4000	3600	3200	2700
	at min. disp.	7000	6250	5600	5000	4250

¹⁾ Contact your Sauer-Danfoss representative for max. speed at displacements between max. and min. displacement.

Speed Limits

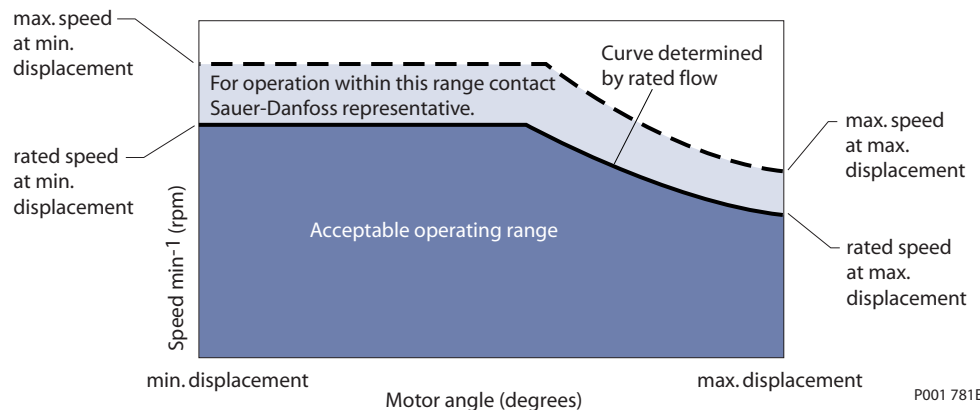

PRESSURE LIMITS

System pressure is the dominant operating variable affecting hydraulic unit life. High pressure, which results from high load, reduces expected life in a manner similar to the affects of high load on other mechanical assemblies such as engines and gear boxes. There are load-to-life relationships for the rotating group and for the shaft anti-friction bearings.

Continuous pressure is the pressure at which the hydrostatic system could operate continuously and still achieve acceptable hydrostatic life. This pressure level varies depending on operating speed, and on the life requirements for a particular application. While most mobile applications require system pressure to vary widely during operation, a “weighted average” pressure can be derived from a machine duty cycle. (A duty cycle is a means of quantifying the pressure and speed demands of a particular system on a percent time basis). Once a duty cycle has been determined or estimated for a specific application, contact your Sauer-Danfoss representative for system life ratings for the application.

Maximum delta pressure is the highest intermittent pressure allowed, and is the relief valve setting. It is determined by the maximum machine load demand. For most systems, the load should move at this pressure.

Maximum pressure is assumed to occur a small percentage of operating time, usually less than 2% of the total. Both the continuous and maximum pressure limits must be satisfied to achieve the expected life.

Minimum low pressure must maintained under all operating conditions to avoid cavitation.

System Pressure Range, Input

	bar	[psid]
Maximum delta pressure	480	[7000]
Minimum low pressure	10	[145]
Maximum pressure	510	[7400]

LOOP FLUSHING

An integral non-adjustable loop flushing valve is incorporated into all these motors. Installations that require fluid to be removed from the low pressure side of the system circuit because of cooling requirements or contamination removal will benefit from loop flushing.

The integral loop flushing valve is equipped with an orificed charge pressure relief valve designed with a cracking pressure of 16 bar [232 psi]. Valves are available with several orifice sizes to meet the flushing flow requirements of all system operating conditions.

The total system charge pump flow should be of sufficient volume to accommodate:

- The number of motors in the system
- System efficiency under worst case conditions
- Pump control requirements
- External needs

**LOOP FLUSHING
 (continued)**

Although charge pump sizing requires the consideration of many system variables, the following table gives a recommendation of what charge pump displacement may be required to accommodate the flushing flow of each available charge relief valve orifice.

Recommended Charge Pump Displacement							
Loop flushing valve	E4	E6	F0	F3	G0	G3	H0
Charge pump size (cm ³)	8	8	11	14	17 or 20	26	34, 47 or 65

Warning: The loss of hydrostatic drive line power in any mode of operation (e.g., forward, reverse, or “neutral” mode) may cause the loss of hydrostatic braking capacity. A braking system, redundant to the hydrostatic transmission must, therefore, be provided which is adequate to stop and hold the system should the condition develop.

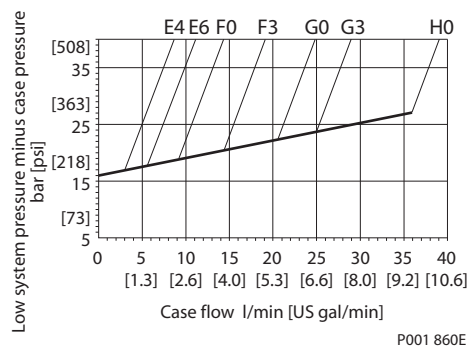
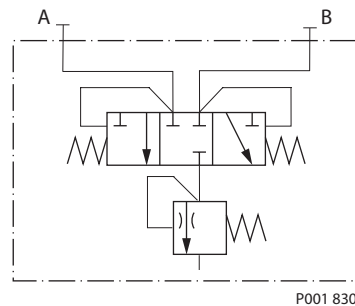
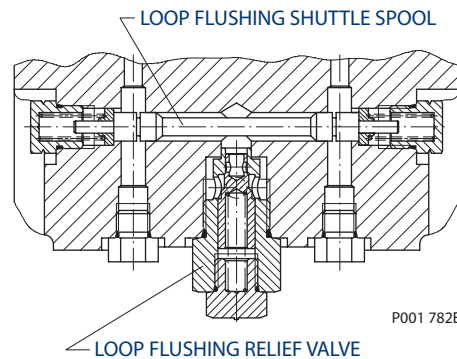

Equation:

$$Q_{\text{Flush}} = \frac{Q_{\text{Charge}} - Q_{\text{Leak}}}{2 \cdot k_{\text{Mo}}}$$

Where:

- Q_{Flush} = flushing flow per motor
- Q_{Charge} = charge flow at operating speed
- k_{Mo} = number of motors fed by one pump
- Q_{Leak} = sum of external leakages including
 - motor leakage
 - pump leakage + internal consumers: 8 l/min [2.11 US gal/min] for displacement control pumps
 - or**
 - for non-feedback controlled pumps at 200 bar [2900 psi]
 - external consumers (e.g. brakes, cylinders, and other pumps)

MINIMUM DISPLACEMENT LIMITER

All Series 51 and 51-1 motors incorporate mechanical displacement limiters. The minimum displacement of the motor is preset at the factory with a set screw in the motor housing. A tamper-proof cap is provided.

HYDRAULIC FLUIDS

Ratings and data are based on operating with hydraulic fluids containing oxidation, rust and foam inhibitors. These fluids must possess good thermal and hydrolytic stability to prevent wear, erosion and corrosion of the internal components.

Fire resistant fluids are also suitable at modified operating conditions. Please see Sauer-Danfoss literature *Hydraulic Fluids and Lubricants Technical Information* for more information.

It is not permissible to mix hydraulic fluids. For more information contact your Sauer-Danfoss representative.

Suitable Hydraulic fluids:

- Hydraulic fluids per DIN 51 524, part 2 (HLP)
- Hydraulic fluids per DIN 51 524, part 3 (HVLP)
- API CD, CE and CF engine fluids per SAE J183
- M2C33F or G automatic transmission fluids (ATF)
- Agricultural multi purpose oil (STOU)
- Premium turbine oils
(for Premium turbine oils contact your Sauer-Danfoss representative).

TEMPERATURE AND VISCOSITY

Temperature and viscosity requirements must be concurrently satisfied. The data shown in the tables assume petroleum-based fluids, are used.

The high temperature limits apply at the hottest point in the transmission, which is normally the motor case drain. The system should generally be run at or below the **rated temperature**. The **maximum temperature** is based on material properties and should never be exceeded.

Cold oil will generally not affect the durability of the transmission components, but it may affect the ability to flow oil and transmit power; therefore temperatures should remain 16 °C [30 °F] above the pour point of the hydraulic fluid. The **minimum temperature** relates to the physical properties of component materials.

For maximum unit efficiency and bearing life the fluid viscosity should remain in the **recommended operating range**. The **minimum viscosity** should be encountered only during brief occasions of maximum ambient temperature and severe duty cycle operation. The **maximum viscosity** should be encountered only at cold start.

Heat exchangers should be sized to keep the fluid within these limits. Testing to verify that these temperature limits are not exceeded is recommended.

**TEMPERATURE AND VISCOSITY
 (continued)**

*Temperature Range*¹⁾

	°C	[°F]	
Minimum	-40	[-40]	intermittent, cold start
Rated	104	[220]	
Maximum	115	[240]	intermittent

¹⁾ At the hottest point, normally the case drain port.

Viscosity

	mm ² /s	[SUS]	
Minimum	7	[49]	intermittent
Recommended operating range	12-80	[70-370]	
Maximum	1600	[7500]	intermittent cold start

FLUID AND FILTRATION

To prevent premature wear, it is imperative that only clean fluid enter the hydrostatic transmission circuit. A filter capable of controlling the fluid cleanliness to ISO 4406 Class 22/18/13 (SAE J1165) or better under normal operating conditions is recommended.

The filter may be located either on the inlet (suction filtration) or discharge (charge pressure filtration) side of the charge pump. The selected filtration system must maintain a cleanliness level of 22/18/13 per ISO 4406.

The selection of a filter depends on a number of factors including the contaminant ingress rate, the generation of contaminants in the system, the required fluid cleanliness, and the desired maintenance interval. Filters are selected to meet the above requirements using rating parameters of efficiency and capacity.

Filter efficiency may be measured with a Beta ratio¹⁾ (β_x). For simple suction-filtered closed circuit transmissions and open circuit transmissions with return line filtration, a filter with a β -ratio within the range of $\beta_{35-45} = 75$ ($\beta_{10} \geq 2$) or better has been found to be satisfactory. For some open circuit systems, and closed circuits with cylinders being supplied from the same reservoir, a considerably higher filter efficiency is recommended. This also applies to systems with gears or clutches using a common reservoir. For these systems, a charge pressure or return filtration system with a filter β -ratio in the range of $\beta_{15-20} = 75$ ($\beta_{10} \geq 10$) or better is typically required.

Since each system is unique, the filtration requirement for that system will be unique and must be determined by test in each case. It is essential that monitoring of prototypes and evaluation of components and performance throughout the test program be the final criteria for judging the adequacy of the filtration system. Please see Sauer-Danfoss literature *Hydraulic Fluids and Lubricants Technical Information* for more information.

¹⁾ Filter β_x -ratio is a measure of filter efficiency defined by ISO 4572. It is defined as the ratio of the number of particles greater than a given diameter ("x" in μm) upstream of the filter to the number of these particles downstream of the filter.

Cleanliness Level and β_x -Ratio

Required Fluid Cleanliness Level	ISO 4406 Class 22-18-13
Recommended β_x -Ratio for Suction Filtration	$\beta_{35-45} = 75$ ($\beta_{10} \geq 2$)
Recommended β_x -Ratio for Charge Pressure Filtration	$\beta_{15-20} = 75$ ($\beta_{10} \geq 10$)
Recommended Inlet Screen Size for Charge Pressure Filtration	100 μm -125 μm

INDEPENDENT BRAKING SYSTEM

Warning: The loss of hydrostatic drive line power in any mode of operation (e.g., forward, reverse, or “neutral” mode) may cause the loss of hydrostatic braking capacity. A braking system, redundant to the hydrostatic transmission must, therefore, be provided which is adequate to stop and hold the system should the condition develop.

RESERVOIR

The function of the reservoir is to remove air and to provide make up fluid for volume changes associated with fluid expansion or contraction, possible cylinder flow, and minor leakage.

The reservoir should be designed to accommodate maximum volume changes during all system operating modes and to promote deaeration of the fluid as it passes through the tank.

A minimum reservoir volume equal to 1/2 to 1 1/2 times charge pump flow/min is suggested. This allows 30 seconds fluid dwell for removing entrained air at the maximum return flow. This is usually adequate to allow for a closed reservoir (no breather) in most applications. The reservoir outlet to the charge pump inlet should be above the bottom of the reservoir to take advantage of gravity separation and prevent large foreign particles from entering the charge inlet line.

The reservoir inlet (fluid return) should be positioned so that the flow to the reservoir is discharged below the normal fluid level, and also directed into the interior of the reservoir for maximum dwell and efficient deaeration.

MOTOR BEARING LIFE

The rated motor bearing life, L_{h10} , shown in the table below, is based on a 90% survival rate of shaft bearings, when operating at a speed of $n = 1500 \text{ min}^{-1}$ (rpm) with a charge pressure of 20 bar [290 psi] and without external shaft load.

Contact your Sauer-Danfoss representative for bearing life values at other pressures and angles.

Lifetimes for speeds other than 1500 min^{-1} (rpm) can be calculated from:

$$L_2 = \frac{L_1 \cdot 1500 \text{ min}^{-1} (\text{rpm})}{n_2} \quad \text{h}$$

$$L_1 = \text{Rated } L_{h10} \text{ life at } 1500 \quad \text{min}^{-1} (\text{rpm})$$

$$n_2 = \text{Operating speed} \quad \text{min}^{-1} (\text{rpm})$$

L_{h10} - Bearing Life (hours)					
Frame size	Effective delta pressure (Δp)		Motor angle (°)		
	bar	[psi]	6	15	32
060	140	[2030]	19 800	18 530	16 370
	210	[3050]	6320	5960	5340
	280	[4060]	2740	2600	2350
080	140	[2030]	14 420	13 580	12 120
	210	[3050]	4610	4370	3960
	280	[4060]	2000	1910	1750
110	140	[2030]	15 800	14 890	13 330
	210	[3050]	5040	4790	4350
	280	[4060]	2180	2090	1920
160	140	[2030]	15 670	14 770	13 200
	210	[3050]	5005	4750	4300
	280	[4060]	2170	2070	1900
250	140	[2030]	11 760	11 130	10 020
	210	[3050]	3750	3580	3260
	280	[4060]	1630	1560	1440

EXTERNAL SHAFT LOADS

Series 51 and 51-1 motors are designed with bearings that can accept external radial and thrust loads.

The external radial shaft load limits are a function of the load position, the load orientation, and operating conditions of the unit.

EXTERNAL SHAFT LOAD ORIENTATION

SAE-Flange design per ISO 3019/1

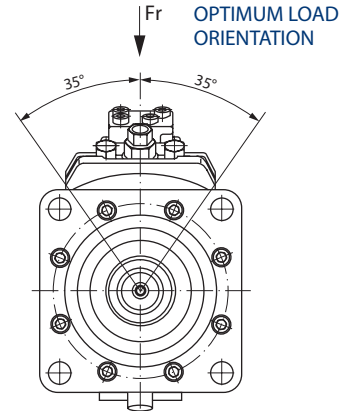
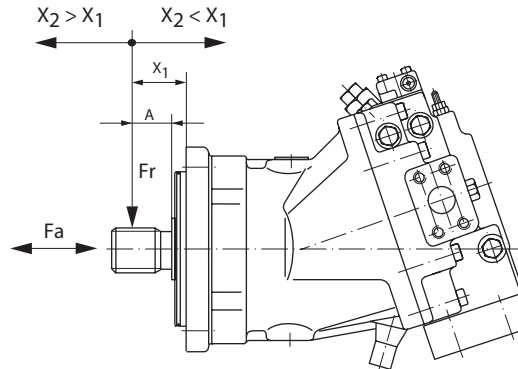

DIN-Flange design per ISO 3019/2

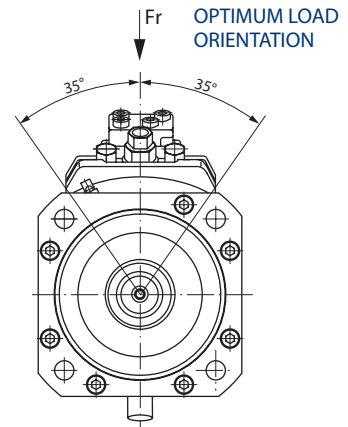
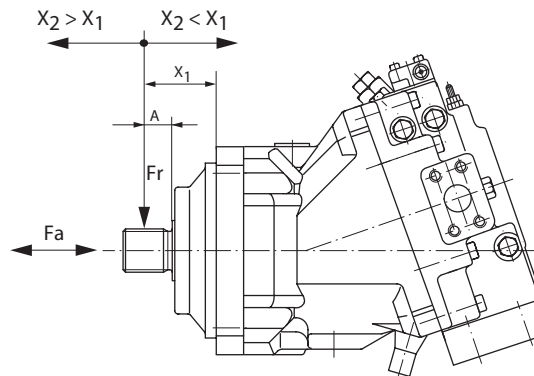

Cartridge Flange design

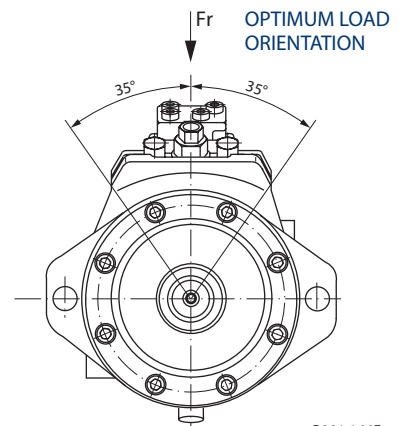
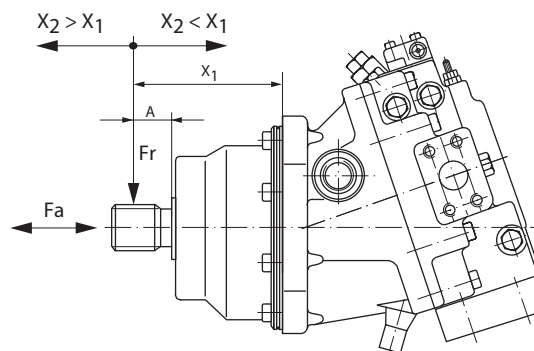

P001 166E

**EXTERNAL SHAFT LOAD
 ORIENTATION
 (continued)**

The table below provides the following information:

- The maximum allowable radial load (**Fr**) based on the distance (x_1) from the mounting flange to the load.
- The maximum allowable axial load (**Fa**).
- The actual distance of (**Fr**) for a given application from the mounting flange to the load is (x_2).
- **A** is the basic distance.
- **Fa/Δp** ratio of allowable axial load, dependent upon system pressure.

The values in the table are maximum values, and are not allowed under continuous load conditions.

Radial and Thrust Loads to the Output Shaft							
Frame size			060	080	110	160	250
Maximum allowable radial load	Fr	N [lbf]	10 000 [2248]	12 000 [2698]	14 000 [3147]	18 000 [4047]	26 000 [5845]
Distance from the SAE-mounting flange	x₁	mm [in]	33.6 [1.32]	33.6 [1.32]	62.7 [2.47]	52.7 [2.07]	45.3 [1.78]
Distance from the DIN-mounting flange	x₁	mm [in]	57.2 [2.25]	57.6 [2.27]	94.7 [3.73]	84.7 [3.33]	—
Distance from the Cartridge design mounting flange	x₁	mm [in]	117.6 [4.63]	136.1 [5.36]	177.5 [7.00]	—	—
Basic distance	A	mm [in]	25.2 [0.99]	25.6 [1.01]	54.7 [2.15]	44.7 [1.76]	37.3 [1.47]
Maximum allowable bending moment	M	Nm [lbf·in]	252 [2230]	307 [2717]	766 [6780]	805 [7125]	970 [8585]
Maximum allowable axial load at zero rpm or running in the idle pressure	Fa	N [lbf]	1100 [247]	1400 [315]	1800 [405]	2500 [562]	4500 [1012]
Maximum allowable axial load at pressure	Fa/Δp	N/bar [lbf/1000 psi]	10.4 [161]	12.6 [195]	15.2 [236]	19.2 [298]	26.4 [409]

— = not available

**ALLOWABLE EXTERNAL
 SHAFT LOAD, WHEN
 SHAFT LOAD DISTANCE
 IS DIFFERENT FROM
 STANDARD**

Use this formula to calculate maximum allowable radial load when max. shaft load distance (X_2) is different from (X_1):

Note:

(X_2) is the actual distance of (**Fr**) from the mounting flange to the load for a given application. If $X_2 < X_1$, (**Fr**) could also be calculated by the first equation, but in addition the bearing life has to be checked.

Contact your Sauer-Danfoss representative for load ratings of specific shafts or when the load orientation deviates more than 35° in either direction from the optimum.

Metric System:

$$X_2 > X_1 \quad Fr = \frac{M \cdot 10^3}{A - X_1 + X_2} \quad N$$

Inch System:

$$X_2 > X_1 \quad Fr = \frac{M \cdot 12}{A - X_1 + X_2} \quad lbf$$

Metric or Inch System:

$$X_2 > X_1 \quad Fr = Fr \text{ max N} \quad lbf$$

**EFFICIENCY GRAPHS
 AND MAPS**

This graph provides the volumetric and overall efficiencies for a typical Series 51 and 51-1 motor operating at maximum displacement, system pressures of 210 and 420 bar [3050 and 6090 psi], and a fluid viscosity of 8.2 mm²/s [53 SUS]. These efficiencies can be used for all frame sizes.

Overall efficiency and volumetric efficiency at maximum displacement

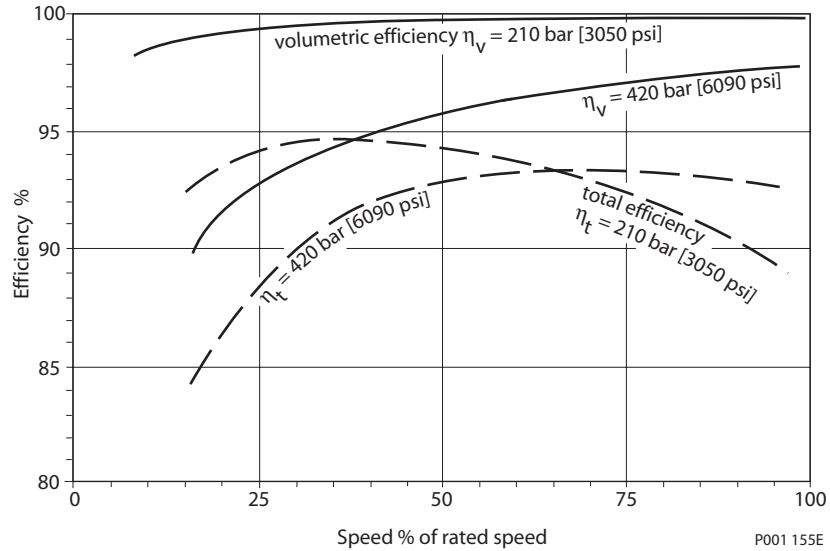

This graph shows typical overall efficiencies for Series 51 and 51-1 motors operating at maximum displacement and system pressures up to 420 bar [6090 psi], and a fluid viscosity of 8.2 mm²/s [53 SUS]. These efficiencies can be used for all frame sizes.

Overall efficiency at maximum displacement

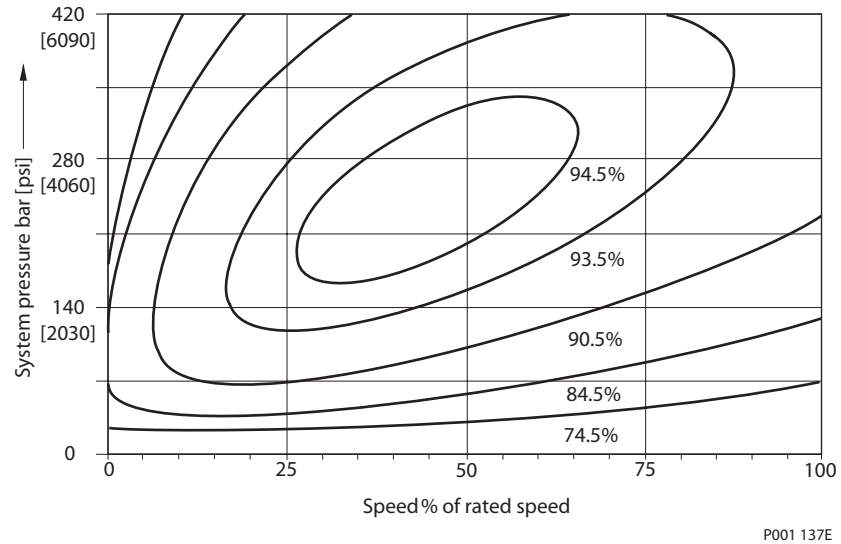

Series 51 and 51-1 Bent Axis Variable Displacement Motors

Technical Information

General Technical Specifications

EFFICIENCY GRAPHS AND MAPS (continued)

This graph shows typical overall efficiencies for Series 51 and 51-1 motors operating at 30% of maximum displacement and system pressures up to 420 bar [6090 psi], and a fluid viscosity of 8.2 mm²/s (53 SUS). These efficiencies can be used for all frame sizes.

Overall efficiency and volumetric efficiency at 30% of maximum displacement

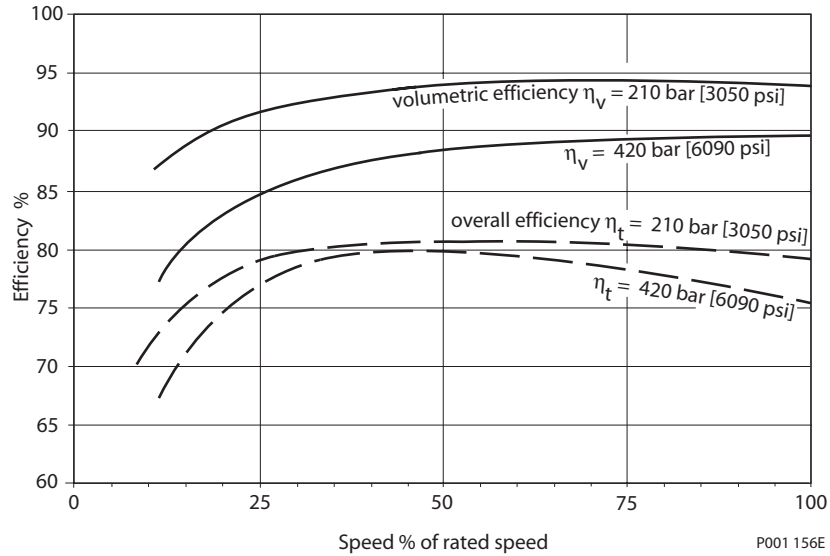

This graph shows typical overall efficiencies for Series 51 and 51-1 motors operating at 30% of maximum displacement and system pressures up to 420 bar [6090 psi], and a fluid viscosity of 8.2 mm²/s (53 SUS). These efficiencies can be used for all frame sizes.

Overall efficiency at 30% of maximum displacement

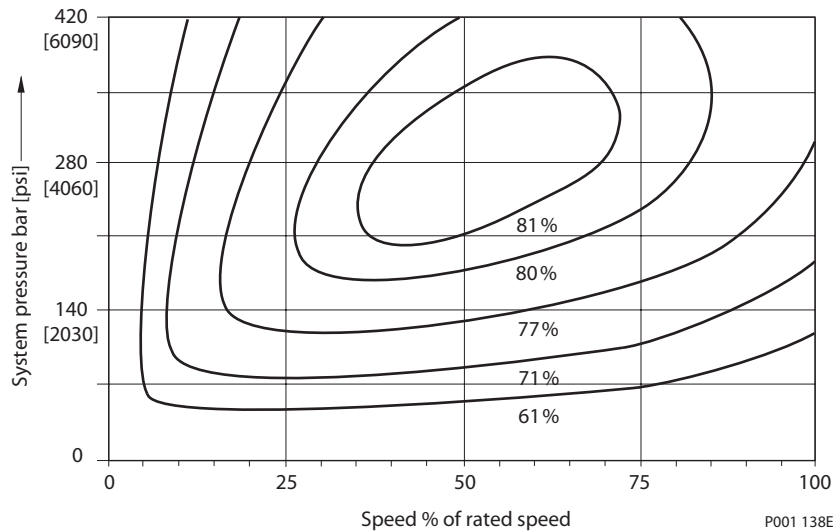

SPEED SENSOR

An optional speed sensor for direct measurement of speed is available. This sensor may also be used to sense the direction of rotation.

A special magnetic speed pick-up ring is pressed onto the outside diameter of the shaft and a Hall effect sensor is located in the motor housing. The sensor accepts supply voltage and outputs a digital pulse signal in response to the speed of the ring. The output changes its high/low state as the north and south poles of the permanently magnetized speed ring pass by the face of the sensor. The digital signal is generated at frequencies suitable for microprocessor based controls.

The sensor is available with different connectors (see below).

The SAE and DIN flange motors use a flat end speed sensor. The cartridge flange motors use a conical end speed sensor.

Contact your Sauer-Danfoss representative for more information.

Data Magnetic Speed Pick-up Ring					
Frame Size	060	080	110	160	250
Pulse/Rev	45	49	54	61	71

Technical Data Speed Sensor	
Supply voltage ¹⁾	4.5-8.5 V _{DC}
Supply voltage regulated	15 V _{DC max.}
Required current	12 mA at 5 V _{DC} (no load)
Max. current	20 mA at 5 V _{DC} and 1 Hz
Max. frequency	15 kHz
Voltage "high"	Supply voltage -0.5 V _{min.}
Voltage "low"	0.5 V _{DC max.}
Temperatur range	-40 to 110 °C [-40 to 230 °F]

Connecting pin designation:

- Pin 1 or A : Supply voltage
- Pin 2 or D : Direction of rotation
- Pin 3 or B : Speed signal, digital
- Pin 4 or C : Gnd common

¹⁾ It is not acceptable to energize the 4.5-8.5 V_{DC} speed sensor with 12 V_{DC} battery voltage; it must be energized by a regulated power supply. If it is desirable to energize the sensor with battery voltage, contact your Sauer-Danfoss representative for an optional speed sensor.

Speed Sensor with Turck Eurofast Connector

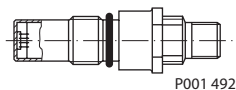

Turck Eurofast Connector Keyway (Ref)
4 pin
 (Supplied connector)
 IP Rating (DIN 40 050) IP 67
 Mating connector
 straight right angle
 No.: K14956 No.: K14957
 Id.-No.: 500724 Id.-No.: 500725

Speed Sensor with Packard Weather-Pack Connector

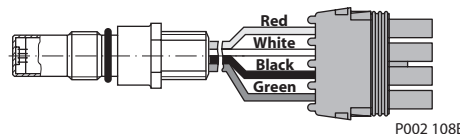

Packard Weather-Pack
4 pin
 (Supplied Connector)
 Mating Connector
 No.: K03379
 Id.-No.: 505341

Series 51 and 51-1 Bent Axis Variable Displacement Motors

Technical Information

Typical Control and Regulator Applications

TYPICAL CONTROL AND REGULATOR APPLICATIONS

The following table is provided to assist in selecting controls and regulators for various applications.

These recommendations are based on experience with a wide range of applications.

Contact your Sauer-Danfoss representative for more information on control selection.

Control and Regulators																
Machine	Function	N1	HZ	TA		E1/E2/E7	F1/F2	T1/T2		TH	EP/EQ		L1/L2/L7	D7/D8	HS	
		A	A	B	C	A	A	B	C	B	A	C	A	C	B	C
Wheel loader	Propel			○	○	○	○	○	○	○			○	○		
Roller compactor	Propel	○	○			○	○									
Paver-Wheeled	Propel	○				○	○									
Paver-Tracked	Propel	○				○	○		○		○		○			
Sweeper	Propel		○											○		○
Trencher	Propel	○	○			○										○
Excavator-Wheeled	Propel									○				○		○
Fork lift truck	Propel												○	○		
Agricultural machines	Propel										○	○	○	○		
Forestry machines	Propel							○	○	○		○		○	○	○
Telescopic handler	Propel			○	○				○	○				○		
Railroad machines	Propel								○		○	○	○	○		
Snow groomer	Propel	○	○			○					○		○			
Snow blower	Propel					○					○			○		
Crane	Winch					○										

A = Control without pressure compensator override
 B = Control with pressure compensator override
 C = Control with pressure compensator override and defe

○ = Suitable configuration



Series 51 and 51-1 Bent Axis Variable Displacement Motors
Technical Information
Notes

**HYDRAULIC
 TWO-POSITION
 CONTROL – OPTION**

N1NN

FOR 51-1

**FRAME SIZE
 060, 080, 110**

Circuit Diagram – Motor with Hydraulic Two-Position Control N1NN

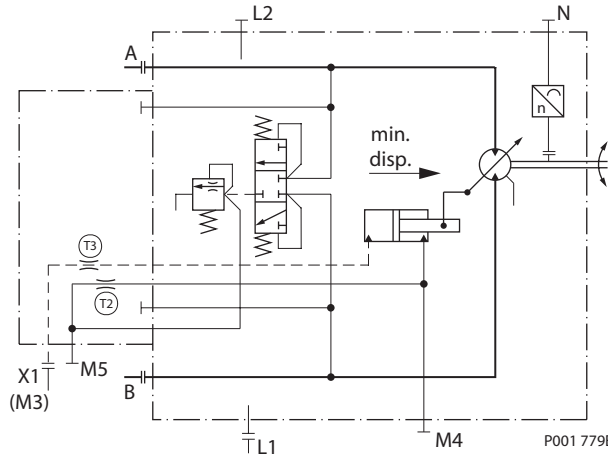

- Ports:
- A, B = Main pressure lines
 - L1, L2 = Drain lines
 - M4 = Gauge port
servo pressure
 - M5 = Gauge port
servo supply pressure
internal
 - X1 (M3) = Control pressure port
 - T2, T3, T3 = Optional orifices
 - N = Speed sensor

Hydraulic Two-Position Control N1NN

Displacement changes from maximum displacement to minimum displacement position, under load, as control pressure at port X1 (M3) is equal to low pressure or higher.

Control Pressure:

- No pressure on port X1 (M3) = maximum displacement
- Control pressure on port X1 (M3) = minimum displacement.
- Max. control pressure X1(M3) = 50 bar [725 psi]

The graph shows the necessary external and internal (= low system pressure) control pressure X1, which is needed to stroke the motor depending on high system pressure.

Control N1NN necessary control pressure

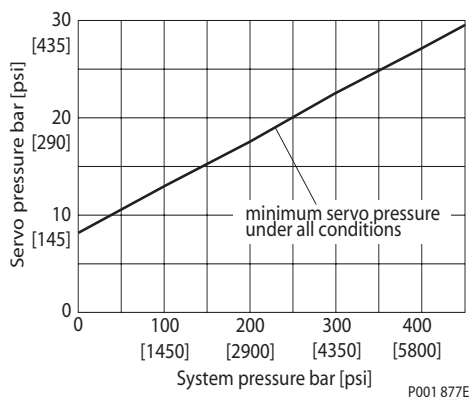

Control Operation N1NN

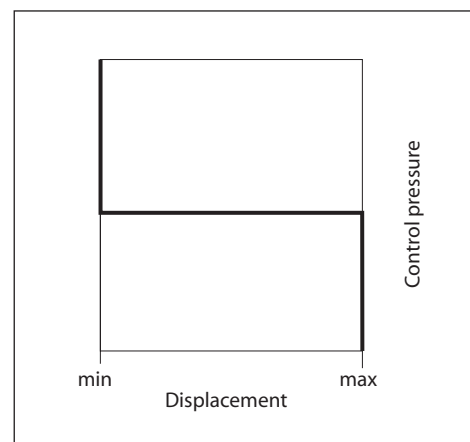

Not all control options are shown in this Technical Information.
 Contact your Sauer-Danfoss representative for special control functions.

**HYDRAULIC
 TWO-POSITION
 CONTROL – OPTION**

HZB1

FOR 51

**FRAME SIZE
 160, 250**

Circuit Diagram – Motor with Hydraulic Two-Position Control HZB1

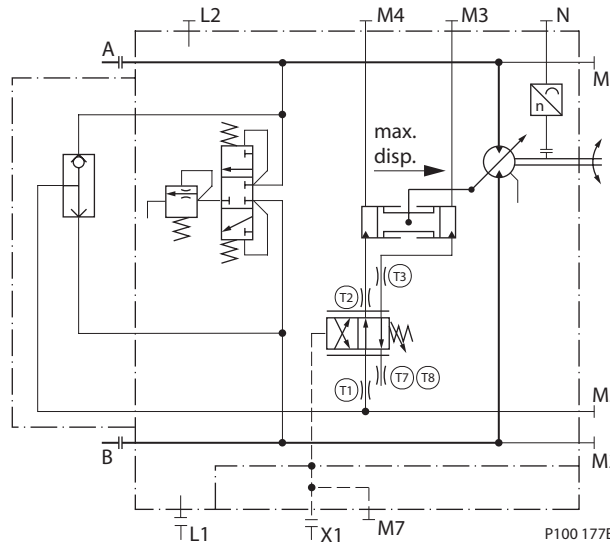

Ports:

- A, B = Main pressure lines
- L1, L2 = Drain lines
- M1, M2 = Gage port for A and B
- M3, M4 = Servo pressure port
- M5 = Gage port
servo supply pressure
internal
- M7 = Gage port
control pressure
- X1 = Control pressure port
- T1, T2, T3, = Optional orifices
- T7, T8
- N = Speed sensor

Hydraulic Two-Position Control HZB1

Displacement can be changed hydraulically under load from minimum displacement to maximum displacement and vice versa by control pressure to port X1.

Control Pressure

- No pressure on port X1 = maximum displacement
- Control pressure on port X1 = minimum displacement.
- Max. control pressure X1 = 50 bar [725 psi]
- The standard control start point setting = 3 bar [44 psi]

Control Operation HZB1

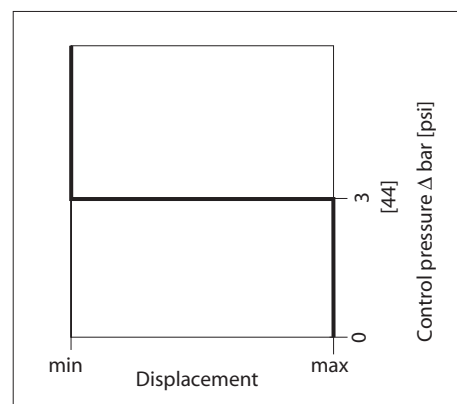

P100 179E

Proportional control, option HZB1 see page 60.

Not all control options are shown in this Technical Information.
 Contact your Sauer-Danfoss representative for special control functions.

PRESSURE COMPENSATOR CONTROL – OPTIONS

TA**

FOR 51-1

FRAME SIZE 060, 080, 110

Circuit Diagram – Motor with Pressure Compensator Control TA**

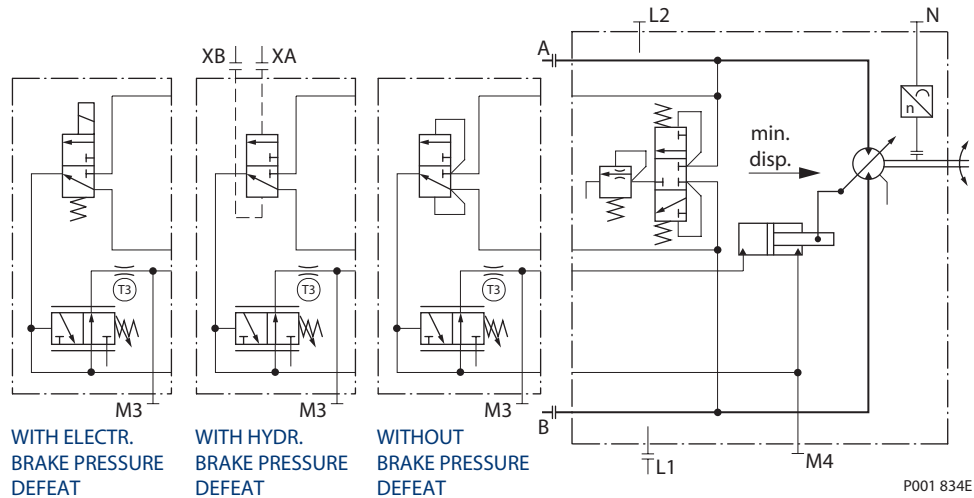

Ports:

- | | | | |
|--------|--|----|----------------|
| A, B | = Main pressure lines | T3 | = Orifice |
| L1, L2 | = Drain lines | N | = Speed sensor |
| M3, M4 | = Gage port servo pressure | | |
| XA, XB | = Control pressure port
brake pressure defeat | | |

Pressure Compensator Control TA**

Displacement is regulated automatically between minimum displacement and maximum displacement in response to system pressure.

- Regulator start = minimum displacement
- Regulator end = maximum displacement

Regulator start pressure is adjustable from 130 to 370 bar [1890 to 5370 psi].

Pressure ramp from regulator start pressure (with motor at minimum displacement) until maximum displacement is reached is less than 10 bar [145 psi]. This ensures optimal power utilization throughout the entire displacement range of the motor.

Not all control options are shown in this Technical Information.
 Contact your Sauer-Danfoss representative for special control functions.

**PRESSURE
 COMPENSATOR
 CONTROL – OPTIONS**

TA**

FOR 51-1

**FRAME SIZE
 060, 080, 110
 (continued)**

Control Operation TA**

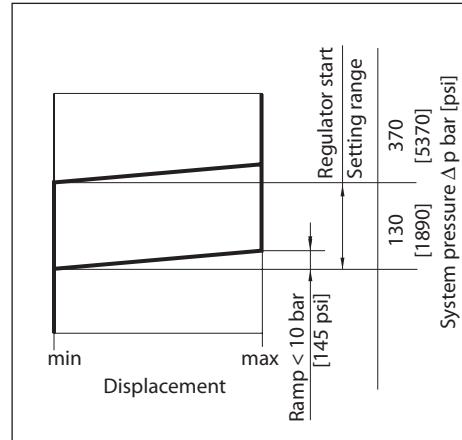

P001 173E

Pressure Compensator Configuration: TACA with Hydraulic Brake Pressure Defeat

A shuttle valve ahead of the pressure compensator prevents operation in the deceleration direction (when motor is running in pump mode). This is designed to prevent rapid or uncontrolled deceleration while the vehicle/machine is slowing down.

The shuttle valve must be controlled by a 2-line external signal, based on direction of motor rotation, based on the following table.

Pressure Compensator Operation			
Rotation	High pressure port	Control pressure on port	PCOR-Function
CW	A	XA	yes
CW	A	XB	no
CCW	B	XA	no
CCW	B	XB	yes

Differential control pressure between port XA/XB

$$\Delta p_{\min} = 0.5 \text{ bar [7 psi]}$$

$$\Delta p_{\max} = 50 \text{ bar [725 psi]}$$

Pressure compensator override with brake pressure defeat is mainly used in systems with pumps having electric or hydraulic proportional controls or automotive controls.

Pressure Compensator Configuration: TAD1, TAD2, TAD7 with Electric Brake Pressure Defeat

A solenoid-switched valve ahead of the pressure compensator prevents operation in the deceleration direction (when motor is running in pump mode). This is designed to prevent rapid or uncontrolled deceleration while the vehicle/machine is slowing down.

The solenoid valve must be controlled by an external electric signal, based on direction of motor rotation, based on the following table.

Not all control options are shown in this Technical Information.

Contact your Sauer-Danfoss representative for special control functions.

**PRESSURE
 COMPENSATOR
 CONTROL – OPTIONS**

TA**

FOR 51-1

**FRAME SIZE
 060, 080, 110
 (continued)**

Pressure Compensator Operation			
Rotation	High pressure port	Solenoid	PCOR-Function
CW	A	energized	yes
CW	A	non energized	no
CCW	B	energized	no
CCW	B	non energized	yes

Solenoid Connectors

**Solenoid plug face
 for DIN 46350**
 (Supplied Connector)

Mating Connector
 No.: K09129
 Id.-No.: 514117

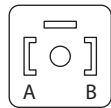

P001 752E

**AMP Junior Timer
 Two Pin Connector**
 (Supplied Connector)

Mating Connector
 No.: K19815
 Id.-No.: 508388

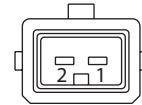

P001 751E

Solenoid Data			
Configuration	Voltage	Electric power	Connector
TAD1	12 V _{DC}	34 W	DIN 46350
TAD7	12 V _{DC}	34 W	AMP Junior Timer two pin connector
TAD2	24 V _{DC}	34 W	DIN 46350

Pressure Compensator Configuration: TAC2 without Brake Pressure Defeat

Pressure compensator functions when the motor is running in motor mode as well as in pump (deceleration) mode.

Pressure Compensator Options		
Configuration	High pressure at port	PCOR-Funktion
TAC2	A and B	yes

Not all control options are shown in this Technical Information.
 Contact your Sauer-Danfoss representative for special control functions.

**PRESSURE
 COMPENSATOR
 CONTROL – OPTIONS**

TA**

FOR 51

**FRAME SIZE
 160, 250**

Circuit Diagram – Motor with Pressure Compensator Control TA**

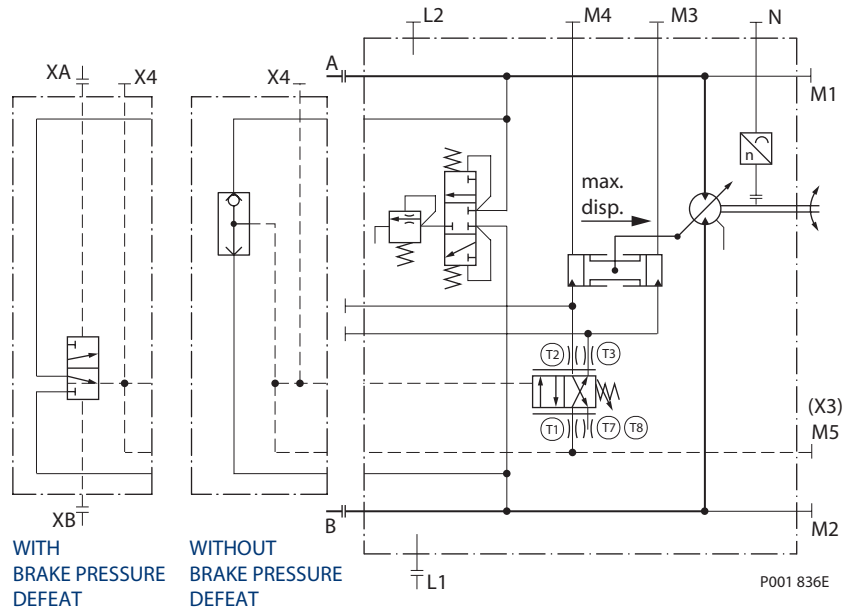

Ports:

- | | | | |
|---------|----------------------------|-------------|---|
| A, B | = Main pressure lines | XA, XB | = Control pressure ports, brake pressure defeat |
| L1, L2 | = Drain lines | X4 | = Gage port pressure compensator |
| M1, M2 | = Gage port for A and B | T1, T2, T3, | = Optional orifices |
| M3, M4 | = Gage port servo pressure | T7, T8 | |
| M5 (X3) | = Gage port servo supply | N | = Speed sensor |

Pressure Compensator Control TA**

Displacement is regulated automatically between minimum displacement and maximum displacement in response to system pressure.

- Regulator start = minimum displacement
- Regulator end = maximum displacement

Regulator start pressure is adjustable from 130 to 370 bar [1890 to 5370 psi].

Pressure ramp from regulator start pressure (with motor at minimum displacement) until maximum displacement is reached is less than 10 bar [145 psi]. This ensures optimal power utilization throughout the entire displacement range of the motor.

Not all control options are shown in this Technical Information.
 Contact your Sauer-Danfoss representative for special control functions.

**PRESSURE
 COMPENSATOR
 CONTROL – OPTIONS**

TA**

FOR 51

**FRAME SIZE
 160, 250
 (continued)**

Control Operation TA**

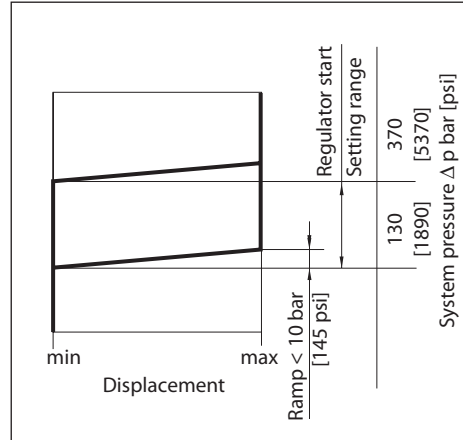

P001 173E

Pressure Compensator Configuration: TAC0 with Hydraulic Brake Pressure Defeat

A shuttle valve ahead of the pressure compensator prevents operation in the deceleration direction (when motor is running in pump mode). This is designed to prevent rapid or uncontrolled deceleration while the vehicle/machine is slowing down.

The shuttle valve must be controlled by a 2-line external signal, based on direction of motor rotation, based on the following table.

Pressure Compensator Operation			
Rotation	High pressure port	Control pressure on port	PCOR-Function
CW	A	XA	no
CW	A	XB	yes
CCW	B	XA	yes
CCW	B	XB	no

Differential control pressure between port XA/XB

$\Delta p_{\min} = 0.5 \text{ bar [7 psi]}$

$\Delta p_{\max} = 50 \text{ bar [725 psi]}$

Pressure compensator override with brake pressure defeat is mainly used in systems with pumps having electric or hydraulic proportional controls or automotive controls.

Pressure Compensator Configuration: TAC2 without Brake Pressure Defeat

Pressure compensator functions when the motor is running in motor mode as well as in pump (deceleration) mode.

Pressure Compensator Options		
Configuration	High pressure at port	PCOR-Funktion
TAC2	A and B	yes

Not all control options are shown in this Technical Information.
 Contact your Sauer-Danfoss representative for special control functions.

**HYDRAULIC
 TWO-POSITION
 CONTROL – OPTIONS**

TH**

FOR 51-1

**FRAME SIZE
 060, 080, 110**

Circuit Diagram – Motor with Two-Position Control TH**

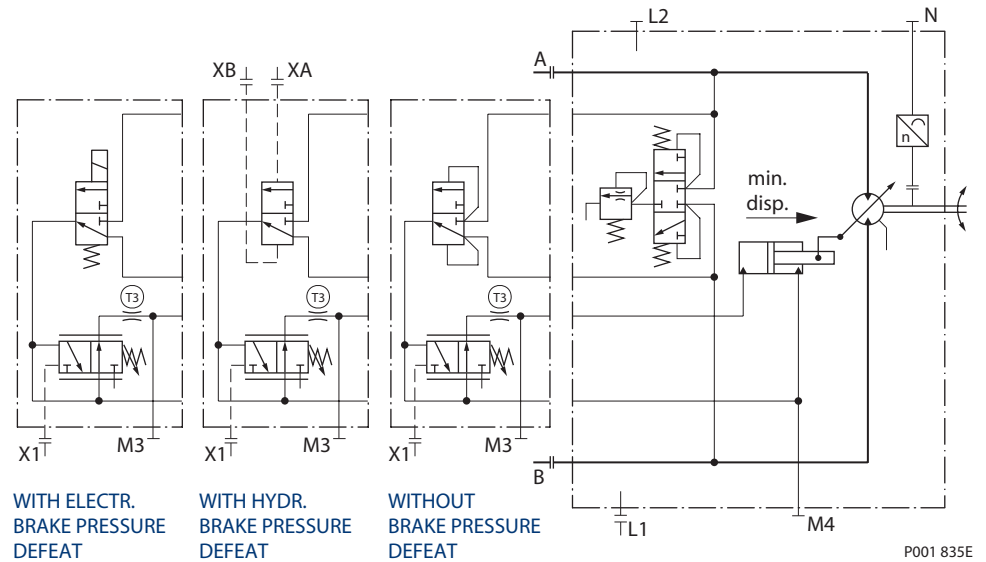

Ports:

- | | | | |
|--------|--|--------|---|
| A, B | = Main pressure lines | XA, XB | = Control pressure ports
brake pressure defeat |
| L1, L2 | = Drain lines | T3 | = Orifice |
| M3, M4 | = Gage port servo pressure | N | = Speed sensor |
| X1 | = Control pressure port,
hydr. override to max. angle | | |

Hydraulic Two-Position Control TH**

Displacement can be changed hydraulically under load from minimum displacement to maximum displacement and vice versa.

Pressure on port X1 must be equal to the pressure of the motor case ± 0.2 bar, [3.0 psi] this keeps the motor at minimum displacement.

Pressure 10 bar, [145 psi] to 35 bar, [510 psi] above case pressure on port X1 strokes the motor to maximum displacement.

Pressure Compensator Override (PCOR)

The control can be overridden by PCOR using high loop pressure.

When the PCOR activates, the motor displacement increases toward maximum. Pressure ramp from PCOR start pressure (with motor at minimum displacement) until maximum displacement is reached is less than 10 bar [145 psi]. This ensures optimal power utilization throughout the entire displacement range of the motor.

PCOR start pressure is adjustable from 130 to 370 bar [1890 to 5370 psi].

Not all control options are shown in this Technical Information.
 Contact your Sauer-Danfoss representative for special control functions.

**HYDRAULIC
 TWO-POSITION
 CONTROL – OPTIONS**

TH**

FOR 51-1

**FRAME SIZE
 060, 080, 110
 (continued)**

Control Operation TH**

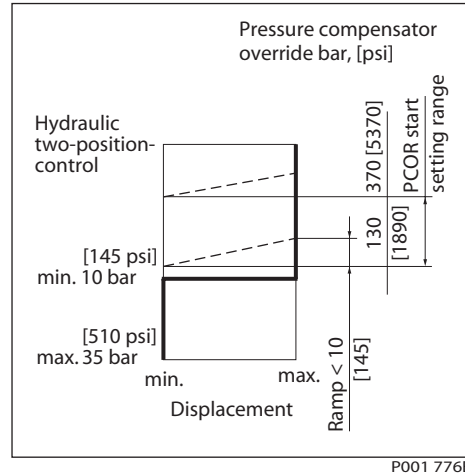

P001 776E

Pressure Compensator Configuration: THCA with Hydraulic Brake Pressure Defeat

A shuttle valve ahead of the pressure compensator prevents operation in the deceleration direction (when motor is running in pump mode). This is designed to prevent rapid or uncontrolled deceleration while the vehicle/machine is slowing down.

The shuttle valve must be controlled by a 2-line external signal, based on direction of motor rotation, based on the following table.

Pressure Compensator Operation			
Rotation	High pressure port	Control pressure on port	PCOR-Function
CW	A	XA	yes
CW	A	XB	no
CCW	B	XA	no
CCW	B	XB	yes

Differential control pressure between port XA/XB

$\Delta p_{min} = 0.5 \text{ bar [7 psi]}$

$\Delta p_{max} = 50 \text{ bar [725 psi]}$

Pressure compensator override with brake pressure defeat is mainly used in systems with pumps having electric or hydraulic proportional controls or automotive controls.

Pressure Compensator Configuration: THD1, THD2, THD7 with Electric Brake Pressure Defeat

A solenoid-switched valve ahead of the pressure compensator prevents operation in the deceleration direction (when motor is running in pump mode). This is designed to prevent rapid or uncontrolled deceleration while the vehicle/machine is slowing down.

The solenoid valve must be controlled by an external electric signal, based on direction of motor rotation, based on the following table.

Not all control options are shown in this Technical Information.

Contact your Sauer-Danfoss representative for special control functions.

**HYDRAULIC
 TWO-POSITION
 CONTROL – OPTIONS**

TH**

FOR 51-1

**FRAME SIZE
 060, 080, 110
 (continued)**

Pressure Compensator Operation			
Rotation	High pressure port	Solenoid	PCOR-Function
CW	A	energized	yes
CW	A	non energized	no
CCW	B	energized	no
CCW	B	non energized	yes

Solenoid Connectors

**Solenoid plug face
 for DIN 46350**
 (Supplied Connector)

Mating Connector
 No.: K09129
 Id.-No.: 514117

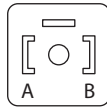

P001 752E

**AMP Junior Timer
 Two Pin Connector**
 (Supplied Connector)

Mating Connector
 No.: K19815
 Id.-No.: 508388

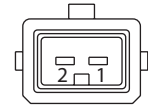

P001 751E

Solenoid Data			
Configuration	Voltage	Electric power	Connector
THD1	12 V _{DC}	34 W	DIN 46350
THD7	12 V _{DC}	34 W	AMP Junior Timer two pin connector
THD2	24 V _{DC}	34 W	DIN 46350

Pressure Compensator Configuration: THC2 without Brake Pressure Defeat

Pressure compensator functions when the motor is running in motor mode as well as in pump (deceleration) mode.

Pressure Compensator Options		
Configuration	High pressure at port	PCOR-Funktion
THC2	A and B	yes

Not all control options are shown in this Technical Information.
 Contact your Sauer-Danfoss representative for special control functions.

**HYDRAULIC
 TWO-POSITION
 CONTROL – OPTIONS**

TH**

FOR 51

**FRAME SIZE
 160, 250**

Circuit Diagram – Motor with Two-Position Control TH**

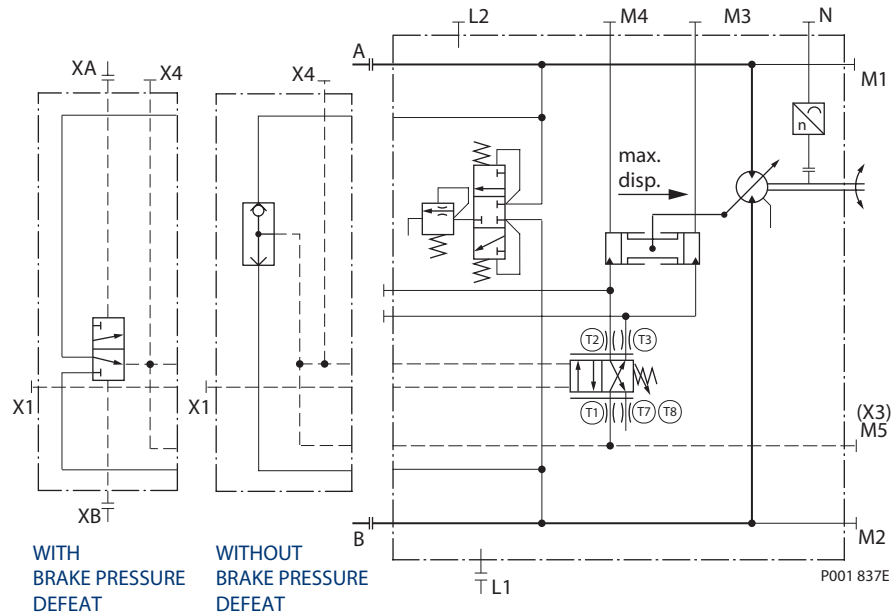

Ports:

- | | | | |
|---------|-----------------------------|-------------|---|
| A, B | = Main pressure lines | X4 | = Gage port pressure compensator |
| L1, L2 | = Drain lines | XA, XB | = Control pressure ports
brake pressure defeat |
| M1, M2 | = Gage port for A and B | T1, T2, T3, | = Optional orifices |
| M3, M4 | = Gage port servo pressure | T7, T8 | |
| M5 (X3) | = Gage port servo supply | N | = Speed sensor |
| X1 | = Hydr. two-position signal | | |

Hydraulic Two-Position Control TH**

Displacement can be changed hydraulically under load from minimum displacement to maximum displacement and vice versa.

Pressure on port X1 must be equal to the pressure of the motor case ± 0.2 bar, [3.0 psi] this keeps the motor at minimum displacement.

Pressure 10 bar, [145 psi] to 35 bar, [510 psi] above case pressure on port X1 strokes the motor to maximum displacement.

Pressure Compensator Override (PCOR)

The control can be overridden by PCOR using high loop pressure. When the PCOR activates, the motor displacement increases to maximum. Pressure ramp from PCOR start pressure (with motor at minimum displacement) until maximum displacement is reached is less than 10 bar [145 psi]. This ensures optimal power utilization throughout the entire displacement range of the motor.

PCOR start pressure is adjustable from 130 to 370 bar [1890 to 5370 psi].

Not all control options are shown in this Technical Information.
 Contact your Sauer-Danfoss representative for special control functions.

**HYDRAULIC
 TWO-POSITION
 CONTROL – OPTIONS**

TH**

FOR 51

**FRAME SIZE
 160, 250
 (continued)**

Control Operation TH**

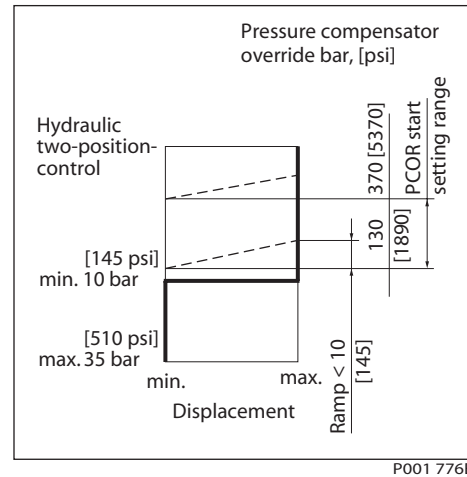

P001 776E

Pressure Compensator Configuration: THC0 with Hydraulic Brake Pressure Defeat

A shuttle valve ahead of the pressure compensator prevents operation in the deceleration direction (when motor is running in pump mode). This is designed to prevent rapid or uncontrolled deceleration while the vehicle/machine is slowing down.

The shuttle valve must be controlled by a 2-line external signal, based on direction of motor rotation, based on the following table.

Pressure Compensator Operation			
Rotation	High pressure port	Control pressure on port	PCOR-Function
CW	A	XA	no
CW	A	XB	yes
CCW	B	XA	yes
CCW	B	XB	no

Differential control pressure between port XA/XB

$$\Delta p_{\min} = 0.5 \text{ bar [7 psi]}$$

$$\Delta p_{\max} = 50 \text{ bar [725 psi]}$$

Pressure compensator override with brake pressure defeat is mainly used in systems with pumps having electric or hydraulic proportional controls or automotive controls.

Pressure Compensator Configuration: THC2 without Brake Pressure Defeat

Pressure compensator functions when the motor is running in motor mode as well as in pump (deceleration) mode.

Pressure Compensator Options		
Configuration	High pressure at port	PCOR-Function
THC2	A and B	yes

Not all control options are shown in this Technical Information.

Contact your Sauer-Danfoss representative for special control functions.

**ELECTROHYDRAULIC
 TWO-POSITION
 CONTROL – OPTIONS**

E1B1, E2B1, E7B1

FOR 51-1

**FRAME SIZE
 060, 080, 110**

Circuit Diagram – Motor with Electrohydraulic Two-Position Control E1B1, E2B1, E7B1

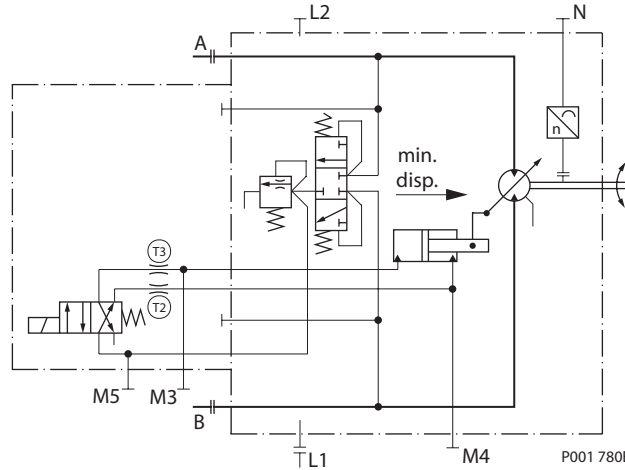

- Ports:
- A, B = Main pressure lines
 - L1, L2 = Drain lines
 - M3, M4 = Servo pressure port
 - M5 = Gage port
 - servo supply pressure internal
 - T2, T3 = Optional orifices
 - N = Speed sensor

Electrohydraulic Two-Position Control

Displacement can be changed electrohydraulically under load from maximum displacement to minimum displacement and vice versa, by using a built-in solenoid valve.

Options E1B1, E2B1, E7B1

- Solenoid off = max. displacement
- Solenoid on = min. displacement

Pilot Pressure for Solenoid:

internal = low pressure

The graph shows the necessary servo pressure (= low pressure), which is needed to stroke the motor, depending on high system pressure and the pump or motor mode.

Control E1B1, E2B1, E7B1 necessary low system pressure

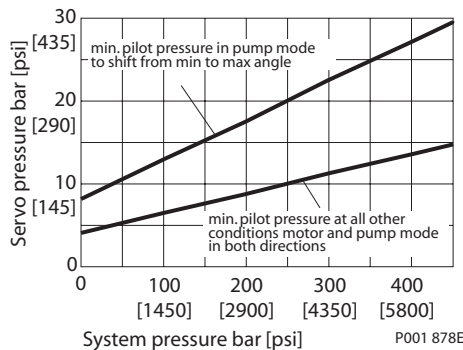

Control Operation E1B1, E2B1, E7B1

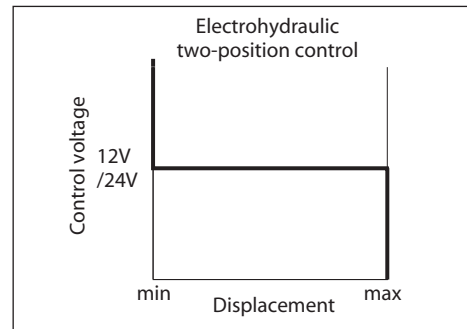

Not all control options are shown in this Technical Information.
 Contact your Sauer-Danfoss representative for special control functions.

**ELECTROHYDRAULIC
 TWO-POSITION
 CONTROL – OPTIONS**

E1B1, E2B1, E7B1

FOR 51-1

**FRAME SIZE
 060, 080, 110
 (continued)**

Solenoid Connectors

**Solenoid plug face
 for DIN 46350**
 (Supplied Connector)

Mating Connector
 No.: K09129
 Id.-No.: 514117

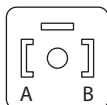

P001 752E

**AMP Junior Timer
 Two Pin Connector**
 (Supplied Connector)

Mating Connector
 No.: K19815
 Id.-No.: 508388

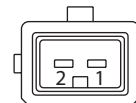

P001 751E

Solenoid Data			
Configuration	Voltage	Electric power	Connector
E1B1	12 V _{DC}	14.7 W	DIN 46350
E7B1	12 V _{DC}	14.7 W	AMP Junior Timer two pin connector
E2B1	24 V _{DC}	14.7 W	DIN 46350

Not all control options are shown in this Technical Information.
 Contact your Sauer-Danfoss representative for special control functions.

**ELECTROHYDRAULIC
 TWO-POSITION
 CONTROL – OPTIONS**

E1A5, E2A5

FOR 51

**FRAME SIZE
 160, 250**

Circuit Diagram–Motor with Electrohydraulic Two-Position Control E1A5, E2A5,

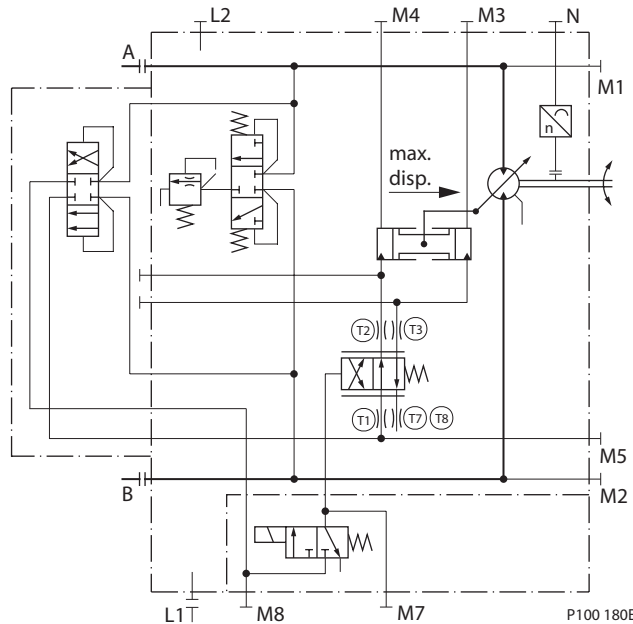

Ports:

- A, B = Main pressure lines
- L1, L2 = Drain lines
- M1, M2 = Gage port for A and B
- M3, M4 = Gage port servo pressure
- M5 = Gage port servo supply pressure, internal
- M7, M8 = Gage port control pressure, internal
- T1, T2, T3, = Optional orifices
- T7, T8
- N = Speed sensor

Electrohydraulic Two-Position Control

Displacement can be changed electrohydraulically under load from maximum displacement to minimum displacement and vice versa, by using a built-in solenoid valve.

Options E1A5, E2A5

Solenoid off = max. displacement
 Solenoid on = min. displacement

Pilot Pressure for Solenoid:

internal = low pressure

Solenoid Connector

**Solenoid plug face
 for DIN 46350**
 (Supplied Connector)

Mating Connector
 No.: K09129
 Id.-No.: 514117

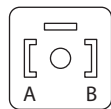

P001 752E

Control Operation E1A5, E2A5

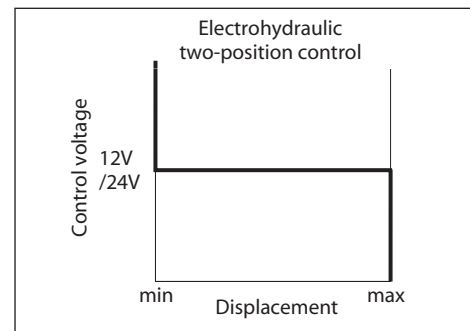

P001 870E

Solenoid Data			
Configuration	Voltage	Electric power	Connector
E1A5	12 V _{DC}	14.7 W	DIN 46350
E2A5	24 V _{DC}		

Not all control options are shown in this Technical Information.
 Contact your Sauer-Danfoss representative for special control functions.

**ELECTROHYDRAULIC
 TWO-POSITION
 CONTROL – OPTIONS**

F1B1,F2B1

FOR 51-1

**FRAME SIZE
 060,080,110**

Circuit Diagram–Motor with Electrohydraulic Two-Position Control F1B1,F2B1,

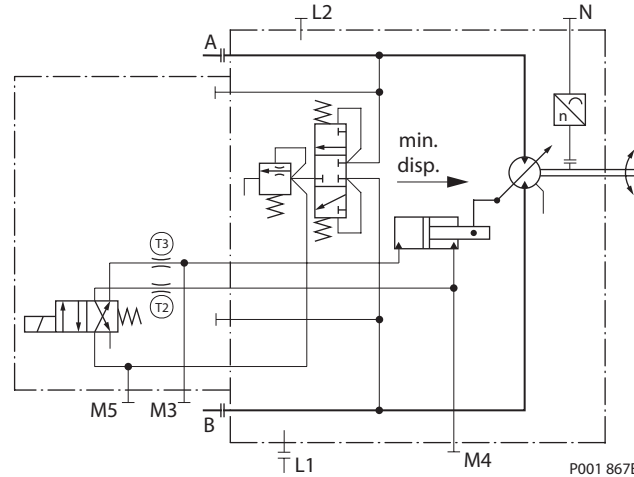

- Ports:
- A, B = Main pressure lines
 - L1, L2 = Drain lines
 - M3, M4 = Servo pressure port
 - M5 = Gage port
servo supply pressure,
internal
 - T2, T3 = Optional orifices
 - N = Speed sensor

Electrohydraulic Two-Position Control

Displacement can be changed electrohydraulically under load from maximum displacement to minimum displacement and vice versa, by using a built-in solenoid valve.

Options F1B1, F2B1

- Solenoid off = min. displacement
- Solenoid on = max. displacement

Pilot Pressure for Solenoid:

- internal = low pressure

The graph shows the necessary servo pressure (= low system pressure), which is needed to stroke the motor, depending on high system pressure and the pump or motor mode.

Control F1B1, F2B1 necessary low system pressure

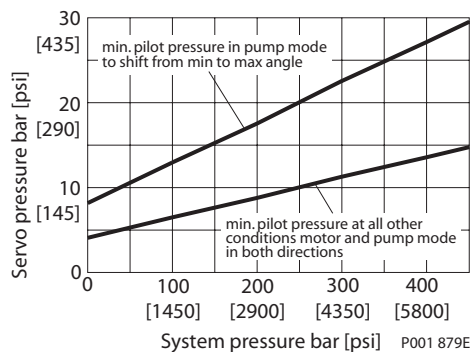

Control Operation F1B1, F2B1

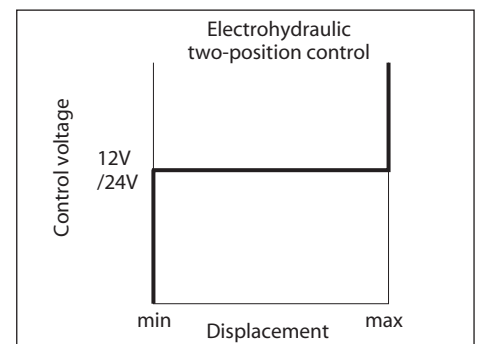

Not all control options are shown in this Technical Information.
 Contact your Sauer-Danfoss representative for special control functions.

**ELECTROHYDRAULIC
 TWO-POSITION
 CONTROL – OPTIONS**

F1B1, F2B1

FOR 51-1

**FRAME SIZE
 060, 080, 110
 (continued)**

Solenoid Connector

**Solenoid plug face
 for DIN 46350**
 (Supplied Connector)

Mating Connector
 No.: K09129
 Id.-No.: 514117

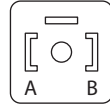

P001 752E

Solenoid Data			
Configuration	Voltage	Electric power	Connector
F1B1	12 V _{DC}	14.7 W	DIN 46350
F2B1	24 V _{DC}		

Not all control options are shown in this Technical Information.
 Contact your Sauer-Danfoss representative for special control functions.

**ELECTROHYDRAULIC
 TWO-POSITION
 CONTROL – OPTIONS**

F1A5, F2A5

FOR 51

**FRAME SIZE
 160, 250**

Circuit Diagram – Motor with Electrohydraulic Two-Position Control F1A5, F2A5

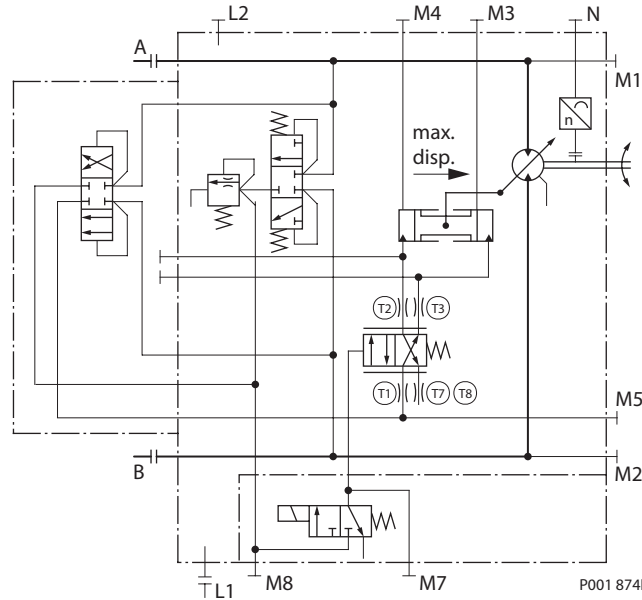

- Ports:
- A, B = Main pressure lines
 - L1, L2 = Drain lines
 - M1, M2 = Gage port for A and B
 - M3, M4 = Gage port servo pressure
 - M5 = Gage port servo supply pressure, internal
 - M7, M8 = Gage port control pressure, internal
 - T1, T2, T3, = Optional orifices
 - T7, T8 =
 - N = Speed sensor

Electrohydraulic Two-Position Control

Displacement can be changed electrohydraulically under load from maximum displacement to minimum displacement and vice versa, by using a built-in solenoid valve.

Options F1A5, F2A5

Solenoid off = min. displacement
 Solenoid on = max. displacement

Pilot Pressure for Solenoid:

internal = low pressure

Solenoid Connector

**Solenoid plug face
 for DIN 46350**
 (Supplied Connector)

Mating Connector
 No.: K09129
 Id.-No.: 514117

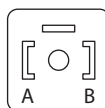

P001 752E

Control Operation F1A5, F2A5

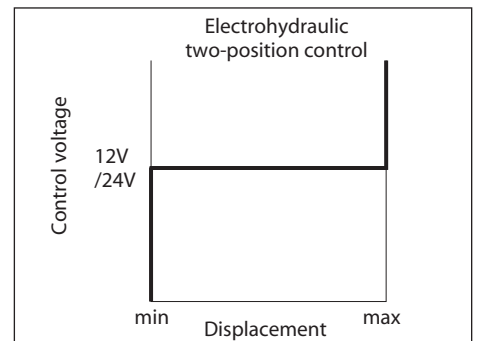

P001 871E

Solenoid Data			
Configuration	Voltage	Electric power	Connector
F1A5	12 V _{DC}	14.7 W	DIN 46350
F2A5	24 V _{DC}		

Not all control options are shown in this Technical Information.
 Contact your Sauer-Danfoss representative for special control functions.

**ELECTROHYDRAULIC
 TWO-POSITION
 CONTROL – OPTIONS**

T1, T2**, T7****

FOR 51-1

**FRAME SIZE
 060, 080, 110**

Circuit Diagram – Motor with Electrohydraulic Two-Position Control T1, T2**, T7****

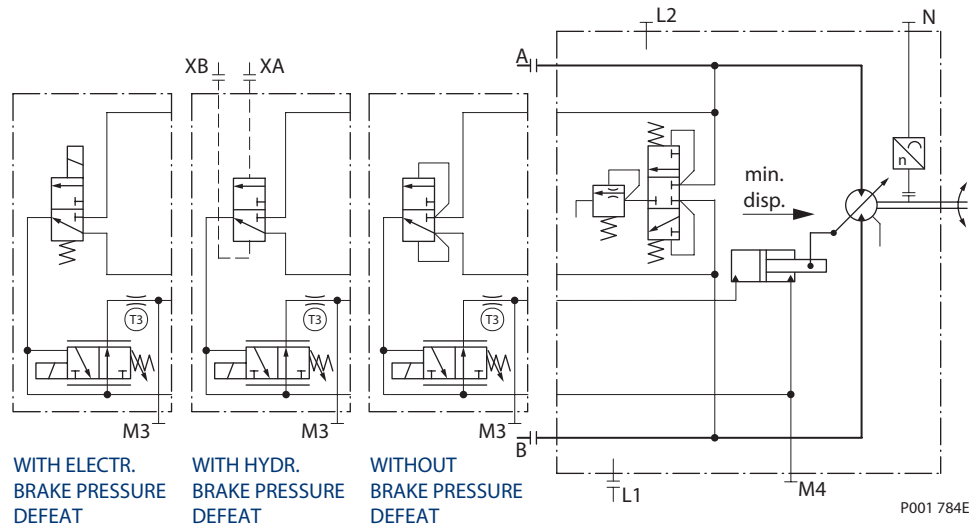

- Ports:
- A, B = Main pressure lines
 - L1, L2 = Drain lines
 - M3, M4 = Gage port servo pressure
 - XA, XB = Control pressure ports, brake pressure defeat
 - T3 = Optional orifices
 - N = Speed sensor

Electrohydraulic Two-Position Control T1, T2**, T7****

Displacement can be changed electrohydraulically under load from minimum displacement to maximum displacement and vice versa, by using a solenoid. When the solenoid is energized the motor has maximum displacement and the pressure compensator does not function.

- Solenoid not energized = minimum displacement
- Solenoid energized = maximum displacement

Pressure Compensator Override (PCOR)

The control can be overridden by PCOR using high loop pressure.

When the PCOR activates, the motor displacement increases toward maximum. Pressure ramp from PCOR start pressure (with motor at minimum displacement) until maximum displacement is reached is less than 10 bar [145 psi]. This ensures optimal power utilization throughout the entire displacement range of the motor.

PCOR start pressure is adjustable from 130 to 370 bar [1890 to 5370 psi].

Not all control options are shown in this Technical Information.
 Contact your Sauer-Danfoss representative for special control functions.

**ELECTROHYDRAULIC
 TWO-POSITION
 CONTROL – OPTIONS**

T1, T2**, T7****

FOR 51-1

**FRAME SIZE
 060, 080, 110
 (continued)**

Control Operation T1, T2**, T7****

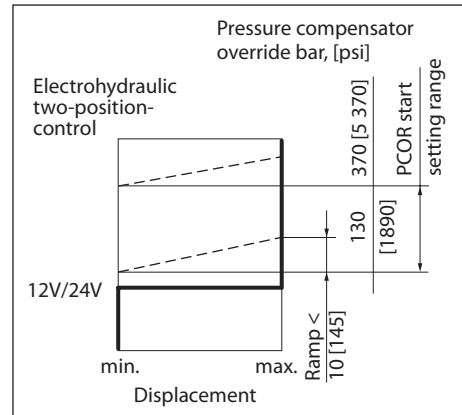

P001 872E

Pressure Compensator Configuration: T*CA with Hydraulic Brake Pressure Defeat

A shuttle valve ahead of the pressure compensator prevents operation in the deceleration direction (when motor is running in pump mode). This is designed to prevent rapid or uncontrolled deceleration while the vehicle/machine is slowing down.

The shuttle valve must be controlled by a 2-line external signal, based on direction of motor rotation, based on the following table.

Pressure Compensator Operation			
Rotation	High pressure port	Control pressure on port	PCOR-Function
CW	A	XA	yes
CW	A	XB	no
CCW	B	XA	no
CCW	B	XB	yes

Differential control pressure between port XA/XB

$$\Delta p_{\min} = 0.5 \text{ bar [7 psi]}$$

$$\Delta p_{\max} = 50 \text{ bar [725 psi]}$$

Pressure compensator override with brake pressure defeat is mainly used in systems with pumps having electric or hydraulic proportional controls or automotive controls.

Pressure Compensator Configuration: T*D1, T*D2, T* D7 with Electric Brake Pressure Defeat

A solenoid-switched valve ahead of the pressure compensator prevents operation in the deceleration direction (when motor is running in pump mode). This is designed to prevent rapid or uncontrolled deceleration while the vehicle/machine is slowing down.

The solenoid valve must be controlled by an external electric signal, based on direction of motor rotation, based on the following table.

Not all control options are shown in this Technical Information.

Contact your Sauer-Danfoss representative for special control functions.

**ELECTROHYDRAULIC
 TWO-POSITION
 CONTROL – OPTIONS**

T1, T2**, T7****

FOR 51-1

**FRAME SIZE
 060, 080, 110
 (continued)**

Pressure Compensator Operation			
Rotation	High pressure port	Solenoid	PCOR-Function
CW	A	energized	yes
CW	A	non energized	no
CCW	B	energized	no
CCW	B	non energized	yes

Solenoid Connectors

**Solenoid plug face
 for DIN 46350**
 (Supplied Connector)

Mating Connector
 No.: K09129
 Id.-No.: 514117

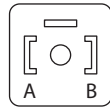

P001 752E

**AMP Junior Timer
 Two Pin Connector**
 (Supplied Connector)

Mating Connector
 No.: K19815
 Id.-No.: 508388

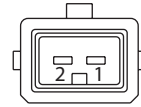

P001 751E

Solenoid Data			
Configuration	Voltage	Electric power	Connector
T1D1	12 V _{DC}	34 W	DIN 46350
T7D7	12 V _{DC}	34 W	AMP Junior Timer two pin connector
T2D2	24 V _{DC}	34 W	DIN 46350

Pressure Compensator Configuration: T*C2 without Brake Pressure Defeat

Pressure compensator functions when the motor is running in motor mode as well as in pump (deceleration) mode.

Pressure Compensator Options		
Configuration	High pressure at port	PCOR-Funktion
T*C2	A and B	yes

Not all control options are shown in this Technical Information.
 Contact your Sauer-Danfoss representative for special control functions.

**ELECTROHYDRAULIC
 TWO-POSITION
 CONTROL – OPTIONS**

T1, T2****

FOR 51

**FRAME SIZE
 160, 250**

Circuit Diagram – Motor with Electrohydraulic Two-Position Control T1, T2****

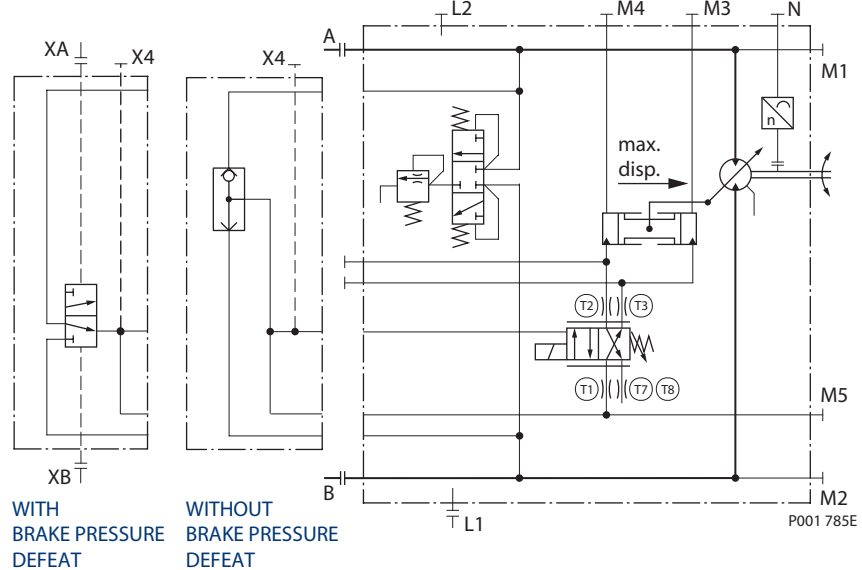

Ports:

- | | | | |
|--------|--|-------------|---|
| A, B | = Main pressure lines | XA, XB | = Control pressure ports, brake pressure defeat |
| L1, L2 | = Drain lines | T1, T2, T3, | = Optional orifices |
| M1, M2 | = Gage port for A and B | T7, T8 | |
| M3, M4 | = Gage port servo pressure | N | = Speed sensor |
| M5 | = Gage port servo supply pressure internal | | |

Electrohydraulic Two-Position Control T1, T2****

Displacement can be changed electrohydraulically under load from minimum displacement to maximum displacement and vice versa, by using a solenoid. When the solenoid is energized the motor has maximum displacement and the pressure compensator is overridden.

- Solenoid not energized = minimum displacement
- Solenoid energized = maximum displacement

Pressure Compensator Override (PCOR)

The control can be overridden by PCOR using high loop pressure.

When the PCOR activates, the motor displacement increases toward maximum. Pressure ramp from PCOR start pressure (with motor at minimum displacement) until maximum displacement is reached is less than 10 bar [145 psi]. This ensures optimal power utilization throughout the entire displacement range of the motor.

PCOR start pressure is adjustable from 130 to 370 bar [1890 to 5370 psi].

Not all control options are shown in this Technical Information.
 Contact your Sauer-Danfoss representative for special control functions.

**ELECTROHYDRAULIC
 TWO-POSITION
 CONTROL – OPTIONS**

T1, T2****

FOR 51

**FRAME SIZE
 160, 250
 (continued)**

Control Operation T1, T2****

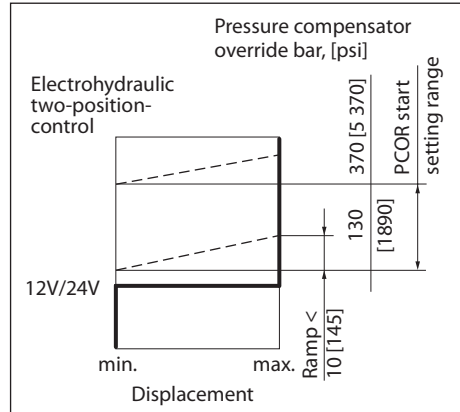

P001 872E

Pressure Compensator Configuration: T*C0 with Hydraulic Brake Pressure Defeat

A shuttle valve ahead of the pressure compensator prevents operation in the deceleration direction (when motor is running in pump mode). This is designed to prevent rapid or uncontrolled deceleration while the vehicle/machine is slowing down. The shuttle valve must be controlled by a 2-line external signal, based on direction of motor rotation, based on the following table.

Pressure Compensator Operation			
Rotation	High pressure port	Control pressure on port	PCOR-Function
CW	A	XA	no
CW	A	XB	yes
CCW	B	XA	yes
CCW	B	XB	no

Differential control pressure between port XA/XB

$$\Delta p_{\min} = 0.5 \text{ bar [7 psi]}$$

$$\Delta p_{\max} = 50 \text{ bar [725 psi]}$$

Pressure compensator override with brake pressure defeat is mainly used in systems with pumps having electric or hydraulic proportional controls or automotive controls.

Pressure Compensator Options		
Configuration	High pressure at port	PCOR-Funktion
T*C2	A and B	yes

Pressure Compensator Configuration: T*C2 without Brake Pressure Defeat

Pressure compensator functions when the motor is running in motor mode as well as in pump (deceleration) mode.

Not all control options are shown in this Technical Information.

Contact your Sauer-Danfoss representative for special control functions.

**ELECTROHYDRAULIC
 TWO-POSITION
 CONTROL – OPTIONS**

T1, T2****

FOR 51

**FRAME SIZE
 160, 250
 (continued)**

Solenoid Connector

**Solenoid plug face
 for DIN 46350**
 (Supplied Connector)

Mating Connector
 No.: K09129
 Id.-No.: 514117

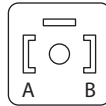

P001 752E

Solenoid Data			
Configuration	Voltage	Electric power	Connector
T1C2	12 V _{DC}	34 W	DIN 46350
T2C2	24 V _{DC}		

Not all control options are shown in this Technical Information.
 Contact your Sauer-Danfoss representative for special control functions.

**ELECTROHYDRAULIC
 PROPORTIONAL
 CONTROL – OPTIONS**

EP, EQ****

FOR 51

**FRAME SIZE
 060, 080, 110, 160, 250**

Circuit Diagram–Motor with Electrohydraulic Proportional Control EP, EQ****

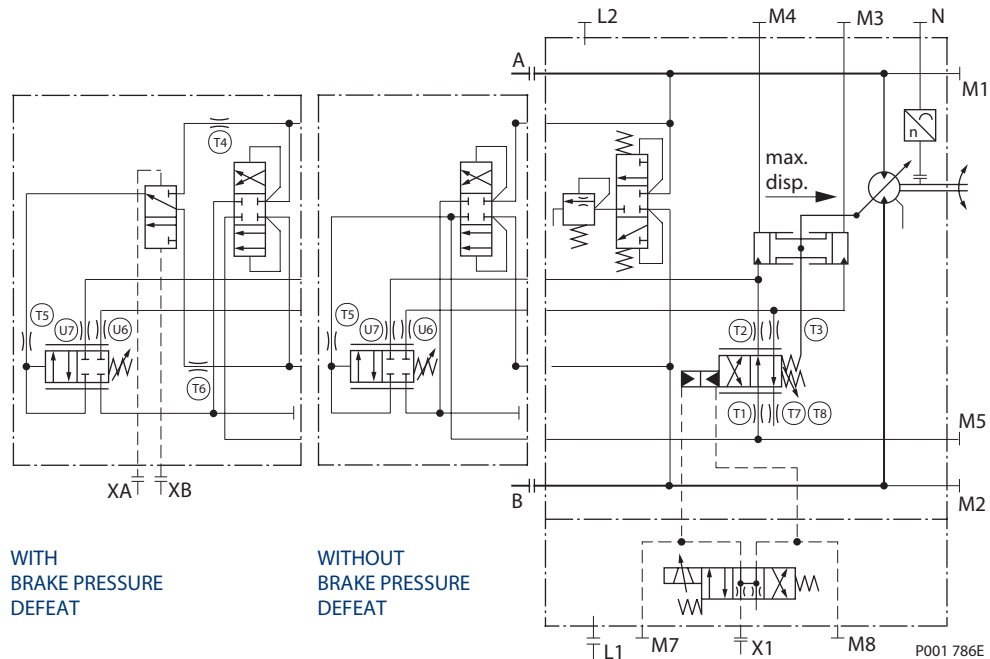

WITH
 BRAKE PRESSURE
 DEFEAT

WITHOUT
 BRAKE PRESSURE
 DEFEAT

Ports:

A, B = Main pressure lines

L1, L2 = Drain lines

M1, M2 = Gage port for A and B

M3, M4 = Gage port servo pressure

M5 = Gage port servo supply
 pressure internal

M7, M8 = Gage port control pressure internal

X1 = Port for control supply
 pressure external

XA, XB = Control pressure ports,
 brake pressure defeat

T1, T2, T3, T4, T5, = Optional orifices

T6, T7, T8, U6, U7

N = Speed sensor

Electrohydraulic Proportional Control EP, EQ****

Displacement can be changed under load in response to an electrical signal between maximum displacement and minimum displacement and vice versa.

Control start = maximum displacement

Control end = minimum displacement

Control Supply Pressure (Port X1):

p_{min} = 20 bar [290 psi]

p_{max} allowable = 70 bar [1015 psi]

Design Options		
Control supply	Connector	
	Packard	MS

Not all control options are shown in this Technical Information.

Contact your Sauer-Danfoss representative for special control functions.

**ELECTROHYDRAULIC
 PROPORTIONAL
 CONTROL – OPTIONS**

EP, EQ****

FOR 51

**FRAME SIZE
 060, 080, 110, 160, 250
 (continued)**

Control Operation EP, EQ****

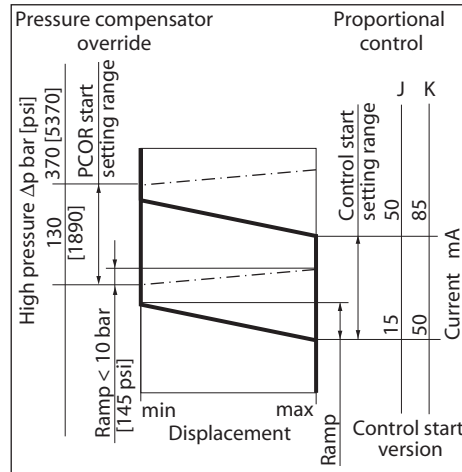

P001 172E

Control Setting Options				
Type	Start current (adjustable) mA	Ramp (max. to min. displ.) (Full stroke current) mA	Standard setting Control start	Coil wiring
JY	15 to 50	70	30 = 30 mA	Single coil
KY	50 to 85		70 = 70 mA	
JW	15 to 50	95	30 = 30 mA	
KW	50 to 85		70 = 70 mA	

Max. current = 250 mA

Coil resistance = 26 Ω

Wiring (maximum to minimum displacement)

Coil wiring	Positiv voltage on pin	Ground on pin
Single coil	B	A
Single coil (alt.)	D	C

Connectors

**MS Connector
 MS3102C-14S-2P**
 (Supplied Connector)

Mating Connector
 No.: K08106
 Id.-No.: 615062



P001 753E

**Packard Weather-Pack
 4 pin**
 (Supplied Connector)

Mating Connector
 No.: K03384
 Id.-No.: 712208

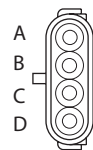

P001 759E

Not all control options are shown in this Technical Information.
 Contact your Sauer-Danfoss representative for special control functions.

**ELECTROHYDRAULIC
 PROPORTIONAL
 CONTROL – OPTIONS**

EP, EQ****

FOR 51

**FRAME SIZE
 060, 080, 110, 160, 250
 (continued)**

Pressure Compensator Override (PCOR)

The control can be overridden by PCOR using high loop pressure.

When the PCOR activates, the motor displacement increases to maximum. Pressure ramp from PCOR start pressure (with motor at minimum displacement) until maximum displacement is reached is less than 10 bar [145 psi]. This ensures optimal power utilization throughout the entire displacement range of the motor.

PCOR start pressure is adjustable from 130 to 370 bar [1890 to 5370 psi].

Configuration Options		
Configuration	PCOR at port	Brake pressure defeat
EPA1/EQA1	A + B	with
EPA2/EQA2	A + B	without

Pressure Compensator Override Configuration: EPA1, EQA1 with Brake Pressure Defeat

A shuttle valve ahead of the pressure compensator prevents operation in the deceleration direction (when motor is running in pump mode). This is designed to prevent rapid or uncontrolled deceleration while the vehicle/machine is slowing down.

The shuttle valve must be controlled by a 2-line external signal, based on direction of motor rotation, based on the following table.

Pressure compensator override with brake pressure defeat is mainly used in systems with pumps having electric or hydraulic proportional controls or automotive controls.

Pressure Compensator Operation			
Rotation	High pressure port	Control pressure on port	PCOR-Function
CW	A	XA	no
CW	A	XB	yes
CCW	B	XA	yes
CCW	B	XB	no

Differential control pressure between port XA/XB

$\Delta p_{min} = 0.5 \text{ bar [7 psi]}$

$\Delta p_{max} = 50 \text{ bar [725 psi]}$

Pressure Compensator Override Configuration: EPA2, EQA2 without Brake Pressure Defeat

The pressure compensator override functions when the motor is running in motor mode as well as in pump (deceleration) mode.

Not all control options are shown in this Technical Information.
 Contact your Sauer-Danfoss representative for special control functions.

ELECTROHYDRAULIC PROPORTIONAL CONTROL – OPTIONS

L1B1, L2B1, L7B1

FOR 51

**FRAME SIZE
 060, 080, 110, 160, 250**

Circuit Diagram – Motor with Electrohydraulic Proportional Control L1B1, L2B1, L7B1

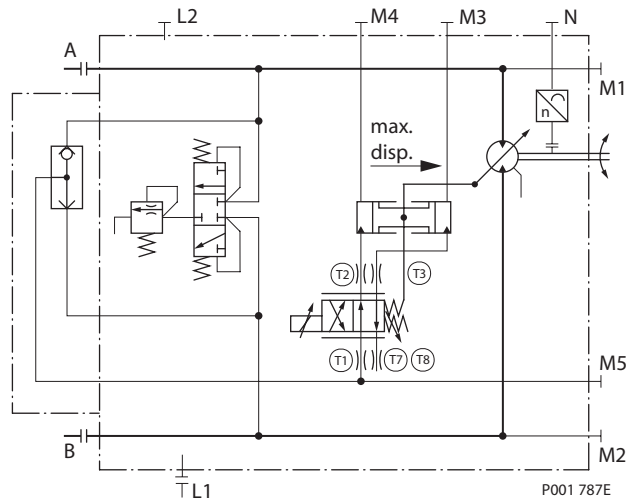

- Ports:
- A, B = Main pressure lines
 - L1, L2 = Drain lines
 - M1, M2 = Gage port for A and B
 - M3, M4 = Gage port servo pressure
 - M5 = Gage port servo supply pressure
 - T1, T2, T3, T7, T8 = Optional orifices
 - N = Speed sensor

Electrohydraulic Proportional Control L1, L2**, L7****

Displacement can be changed electrohydraulically under load in response to an electrical signal from minimum displacement to maximum displacement and vice versa. The displacement changes proportional to the electrical signal. The electrical signal must be a pulse-width modulated (PWM) signal, (f = 100...200 Hz).

Control start = maximum displacement
 Control end = minimum displacement

Control Operation L1, L2**, L7****

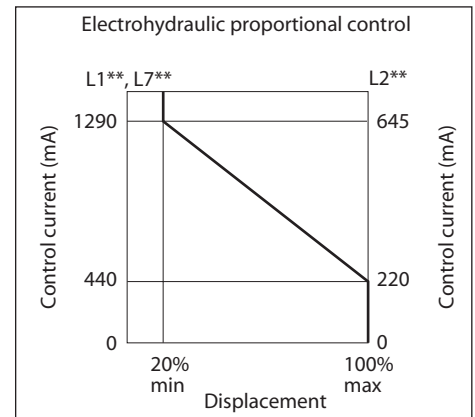

Solenoid Connectors

Solenoid plug face for DIN 46350
 (Supplied Connector)

Mating Connector
 No.: K09129
 Id.-No.: 514117

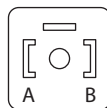

P001 752E

AMP Junior Timer Two Pin Connector
 (Supplied Connector)

Mating Connector
 No.: K19815
 Id.-No.: 508388

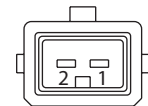

P001 751E

Solenoid Data

Configuration	Voltage	nominal resistance 20 °C	Control current			Connector
			Start	End	max.	
L1B1	12 V _{DC}	5.7 Ω	440 mA	1290 mA	1500 mA	DIN 46350
L7B1						AMP Junior Timer two pin connector
L2B1	24 V _{DC}	21.3 Ω	220 mA	645 mA	750 mA	DIN 46350

Not all control options are shown in this Technical Information.
 Contact your Sauer-Danfoss representative for special control functions.

**ELECTROHYDRAULIC
 PROPORTIONAL
 CONTROL – OPTIONS**

D7M1, D8M1

FOR 51

**FRAME SIZE
 060, 080, 110, 160, 250**

**Circuit Diagram–Motor with Electrohydraulic Proportional Control D7M1, D8M1
 with Pressure Compensator (PCOR) and Hydraulic Brake Pressure Defeat**

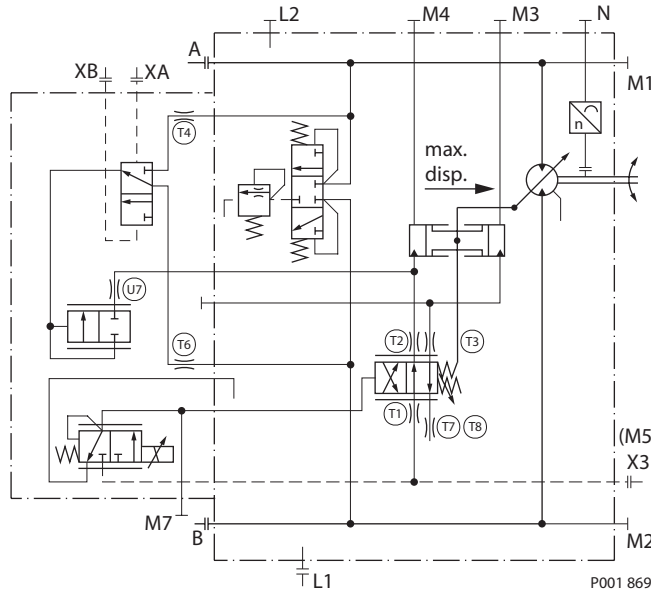

- Ports:
- A, B = Main pressure lines
 - L1, L2 = Drain lines
 - M1, M2 = Gage port for A and B
 - M3, M4 = Gage port servo pressure
 - X3 (M5) = Servo pressure supply
 - M7 = Gage port control pressure
 - XA, XB = Control pressure ports hydr. brake pressure defeat
 - T1, T2, T3, = Optional orifices
 - T4, T6, T7, T8, U7 = Speed sensor
 - N = Speed sensor

**Electrohydraulic Proportional Control
 D7M1, D8M1**

Displacement can be changed electrohydraulically under load in response to an electrical signal from minimum displacement to maximum displacement and vice versa. The displacement changes proportional to the electrical signal. The electrical signal must be a pulse-width modulated (PWM) signal, (f = 100...200 Hz).

Solenoid not energized = maximum displacement
 Solenoid energized = minimum displacement

Servo pressure supply = external pressure at X3

min. pressure = 25 bar [360 psi]
 max. pressure = 50 bar [725 psi]

Control Operation D7M1, D8M1

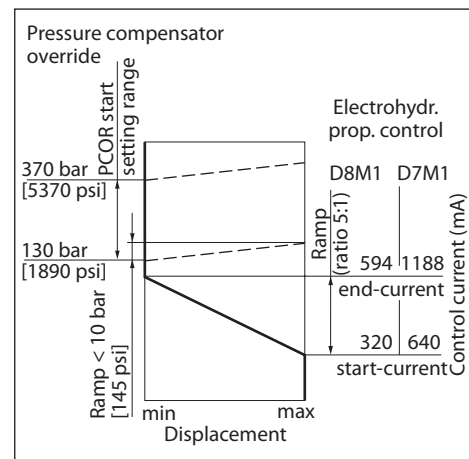

Not all control options are shown in this Technical Information.
 Contact your Sauer-Danfoss representative for special control functions.

**ELECTROHYDRAULIC
 PROPORTIONAL
 CONTROL – OPTIONS**

D7M1, D8M1

FOR 51

**FRAME SIZE
 060, 080, 110, 160, 250
 (continued)**

Pressure Compensator Override (PCOR)

The control can be overridden by PCOR using high loop pressure.

When the PCOR activates, the motor displacement increases to maximum. Pressure ramp from PCOR start pressure (with motor at minimum displacement) until maximum displacement is reached is less than 10 bar [145 psi]. This ensures optimal power utilization throughout the entire displacement range of the motor.

PCOR start pressure is adjustable from 130 to 370 bar [1890 to 5370 psi].

Pressure Compensator Configuration: D7M1, D8M1 with Hydraulic Brake Pressure Defeat

A shuttle valve ahead of the pressure compensator prevents operation in the deceleration direction (when motor is running in pump mode). This is designed to prevent rapid or uncontrolled deceleration while the vehicle/machine is slowing down.

The shuttle valve must be controlled by a 2-line external signal, based on direction of motor rotation, based on the following table.

Pressure compensator override with brake pressure defeat is mainly used in systems with pumps having electric or hydraulic proportional controls or automotive controls.

Pressure Compensator Operation			
Rotation	High pressure port	Control pressure on port	PCOR-Function
CW	A	XA	no
CW	A	XB	yes
CCW	B	XA	yes
CCW	B	XB	no

Differential control pressure between port XA/XB

$\Delta p_{\min} = 0.5 \text{ bar [7 psi]}$

$\Delta p_{\max} = 50 \text{ bar [725 psi]}$

Solenoid Connector

**AMP Junior Timer
 Two Pin Connector**
 (Supplied Connector)

Mating Connector
 No.: K19815
 Id.-No.: 508388

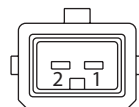

P001 751E

Solenoid Data						
Configuration	Voltage	nominal resistance 20 °C	Control current			Connector
			Start	End	max.	
D7M1	12 V _{DC}	5.7 Ω	640 mA	1188 mA	1500 mA	AMP Junior Timer two pin connector
D8M1	24 V _{DC}	21.2 Ω	320 mA	594 mA	750 mA	

Not all control options are shown in this Technical Information.

Contact your Sauer-Danfoss representative for special control functions.

**HYDRAULIC
 PROPORTIONAL
 CONTROL – OPTIONS**

HS**

FOR 51

**FRAME SIZE
 060, 080, 110, 160, 250**

Circuit Diagram – Motor with Hydraulic Proportional Control HS**

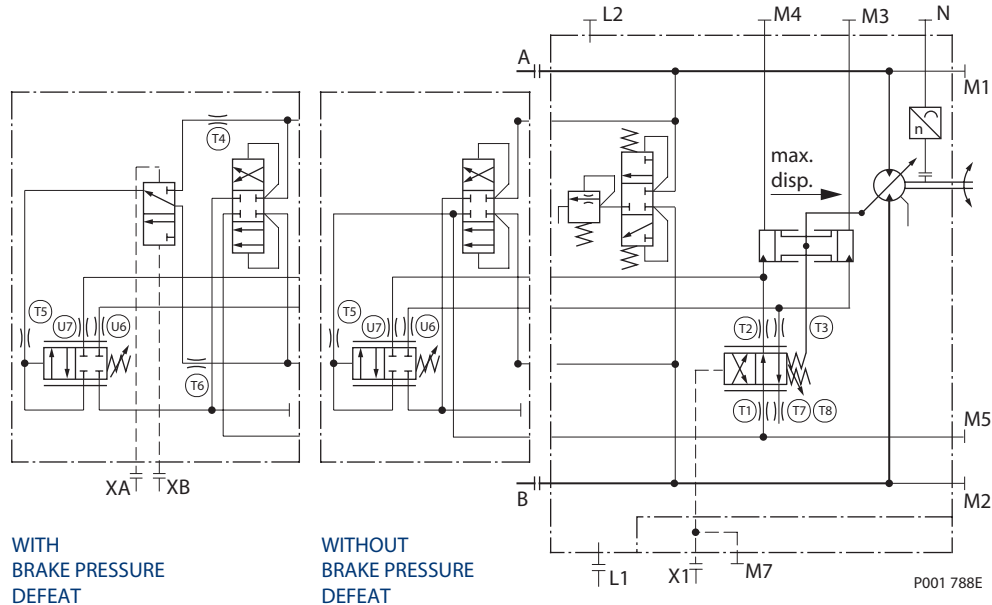

WITH
 BRAKE PRESSURE
 DEFEAT

WITHOUT
 BRAKE PRESSURE
 DEFEAT

Ports:

- A, B = Main pressure lines
- L1, L2 = Drain lines
- M1, M2 = Gage port or A and B
- M3, M4 = Gage port servo pressure
- M5 = Gage port
- servo supply pressure internal
- M7 = Gage port control pressure

- X1 = Control pressure port
- XA, XB = Control pressure ports
brake pressure defeat
- T1, T2, T3, T4, = Optional orifices
- T5, T6, T7, T8, U6, U7 =
- N = Speed sensor

Hydraulic Proportional Control HS**

Displacement can be changed in response to a hydraulic signal under load between maximum displacement and minimum displacement and vice versa.

Control start = maximum displacement
 Control end = minimum displacement

Control Pressure (Port X1):

External = Absolute pressure

Maximum allowable Control Pressure (Port X1):

$p_{\text{max allowable}} = \text{Control start pressure} + 50 \text{ bar [725 psi]}$

Control Operation HS**

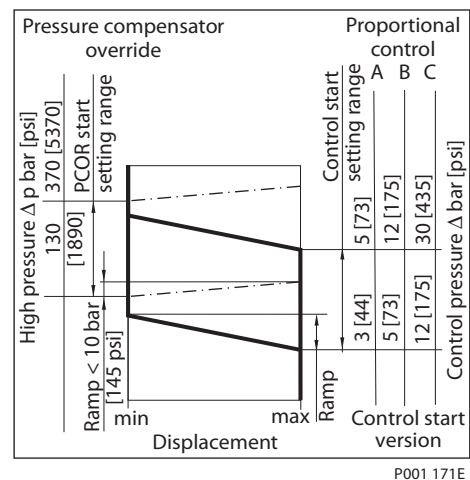

Not all control options are shown in this Technical Information.
 Contact your Sauer-Danfoss representative for special control functions.

**HYDRAULIC
 PROPORTIONAL
 CONTROL – OPTIONS**

HS**

FOR 51

**FRAME SIZE
 060, 080, 110, 160, 250
 (continued)**

Control Start	
Control start range (adjustable)	
bar	[psi]
3 to 5	[44 to 73]
5 to 12	[73 to 175]
12 to 30	[175 to 435]

Control Ramp	
Control ramp range from max. to min. displ. (control pressure rise)	
bar	[psi]
7	[102]
14	[206]

Pressure Compensator Override (PCOR)

The control can be overridden by PCOR using high loop pressure.

When the PCOR activates, the motor displacement increases to maximum. Pressure ramp from PCOR start pressure (with motor at minimum displacement) until maximum displacement is reached is less than 10 bar [145 psi]. This ensures optimal power utilization throughout the entire displacement range of the motor.

PCOR start pressure is adjustable from 130 to 370 bar [1890 to 5370 psi].

Configuration Options		
Configuration	PCOR at port	Brake pressure defeat
HSA1	A + B	with
HSA2	A + B	without

Pressure Compensator Override Configuration: HSA1 with Brake Pressure Defeat

A shuttle valve ahead of the pressure compensator prevents operation in the deceleration direction (when motor is running in pump mode). This is designed to prevent rapid or uncontrolled deceleration while the vehicle/machine is slowing down.

The shuttle valve must be controlled by a 2-line external signal, based on direction of motor rotation, based on the following table.

Pressure compensator override with brake pressure defeat is mainly used in systems with pumps having electric or hydraulic proportional controls or automotive controls.

Pressure Compensator Operation			
Rotation	High pressure port	Control pressure on port	PCOR-Function
CW	A	XA	no
CW	A	XB	yes
CCW	B	XA	yes
CCW	B	XB	no

Differential control pressure between port XA/XB

$$\Delta p_{\min} = 0.5 \text{ bar [7 psi]}$$

$$\Delta p_{\max} = 50 \text{ bar [725 psi]}$$

Pressure Compensator Override Configuration: HSA2 without Brake Pressure Defeat

The pressure compensator override functions when the motor is running in motor mode as well as in pump (deceleration) mode.

Not all control options are shown in this Technical Information.

Contact your Sauer-Danfoss representative for special control functions.

**HYDRAULIC
 PROPORTIONAL
 CONTROL – OPTION**

HZB1

FOR 51

**FRAME SIZE
 060, 080, 110, 160, 250**

Circuit Diagram – Motor with Hydraulic Proportional Control HZB1

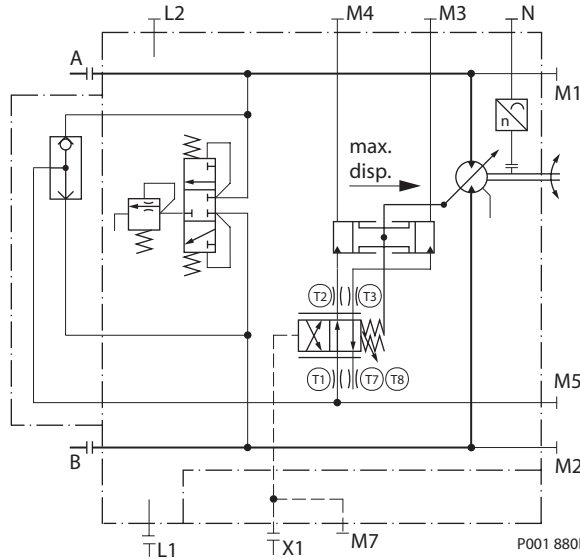

- Ports:
- A, B = Main pressure lines
 - L1, L2 = Drain lines
 - M1, M2 = Gage port for A and B
 - M3, M4 = Servo pressure port
 - M5 = Gage port
servo supply pressure
internal
 - M7 = Gage port control pressure
 - X1 = Control pressure port
 - T1, T2, T3, = Optional orifices
 - T7, T8
 - N = Speed sensor

Hydraulic Proportional Control HZB1

Displacement can be changed in response to a hydraulic signal under load between maximum displacement and minimum displacement and vice versa.

Control start = maximum displacement
 Control end = minimum displacement

Control Pressure (Port X1):
 External = Absolute pressure

Maximum allowable Control Pressure (Port X1):

$$p_{\text{max allowable}} = \text{Control start pressure} + 50 \text{ bar [725 psi]}$$

Control Operation HZB1

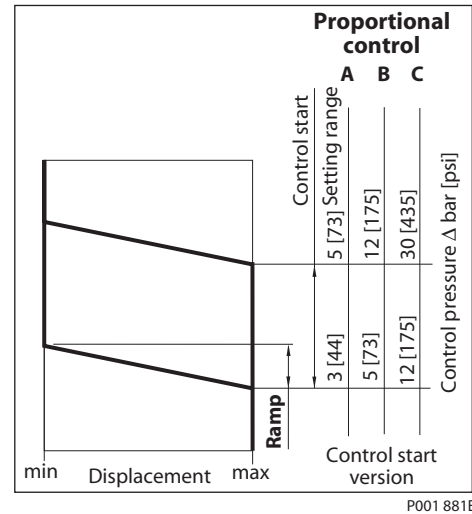

Control Start	
Control start range (adjustable)	
bar	[psi]
3 to 5	[44 to 73]
5 to 12	[73 to 175]
12 to 30	[175 to 435]

Control Ramp	
Control ramp range from max. to min. displ. (control pressure rise)	
bar	[psi]
7	[102]
14	[206]

Two-position control, option HZB1 see page 29.

Not all control options are shown in this Technical Information.
 Contact your Sauer-Danfoss representative for special control functions.



Series 51 and 51-1 Bent Axis Variable Displacement Motors
Technical Information
Notes

**SAE FLANGE DESIGN
 PER ISO 3019/1**

51V060-1 Two Position Control, N1NN

mm
 [in]

Side Port

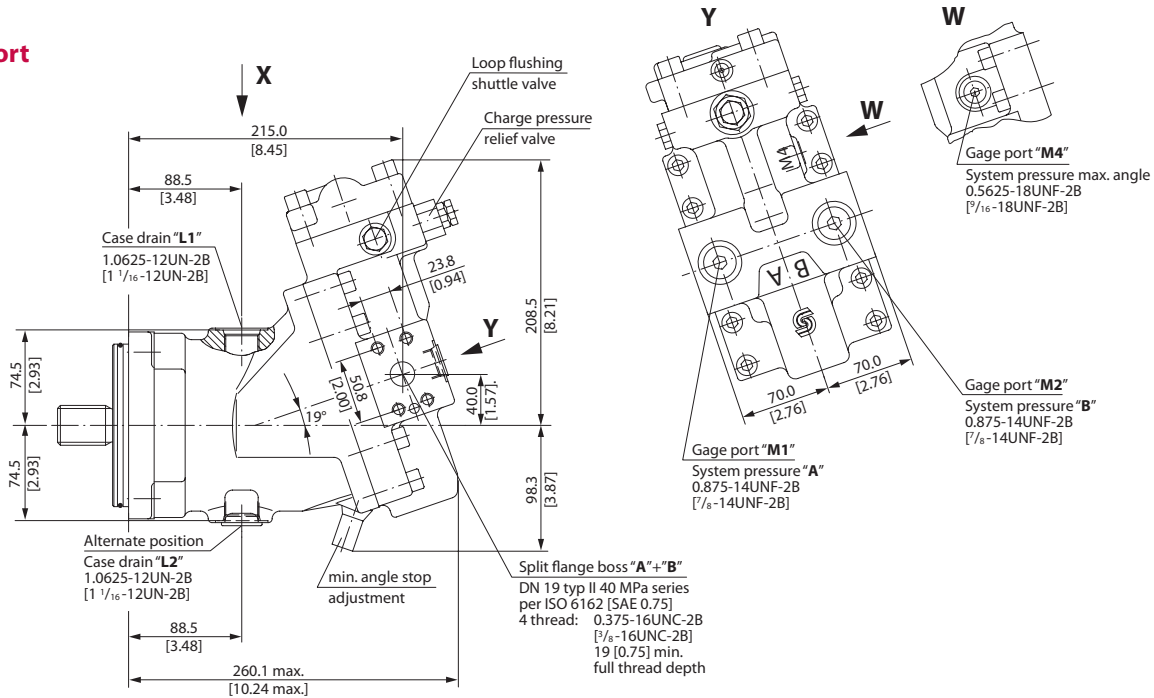

Axial Port

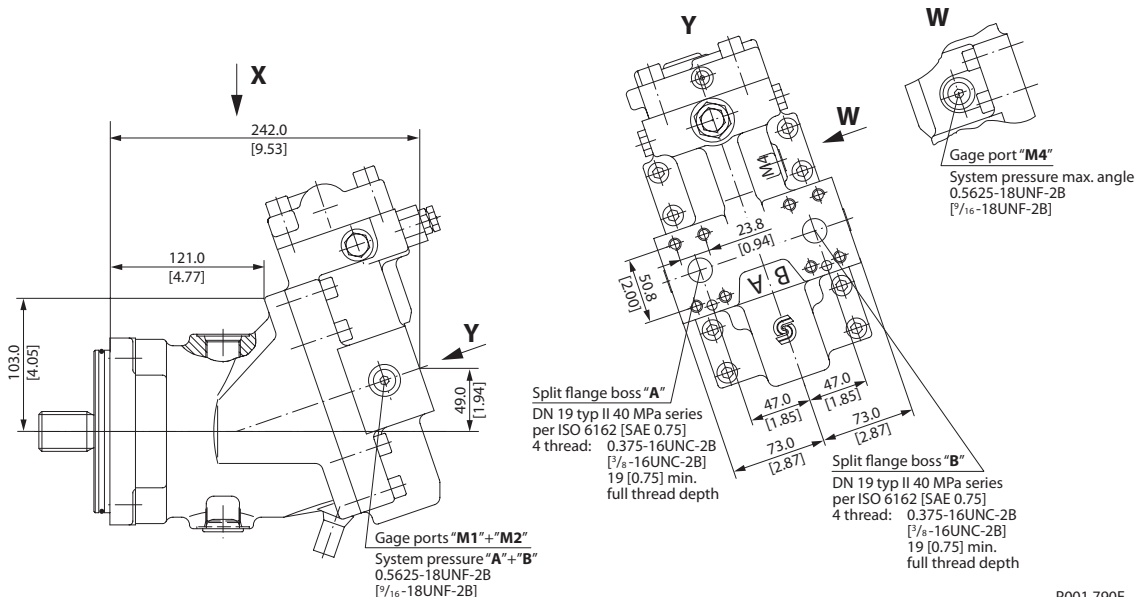

P001 790E

**SAE FLANGE DESIGN
 PER ISO 3019/1
 (continued)**

51V060 Proportional and Two Position Control, HZB1

mm
 [in]

Side Port

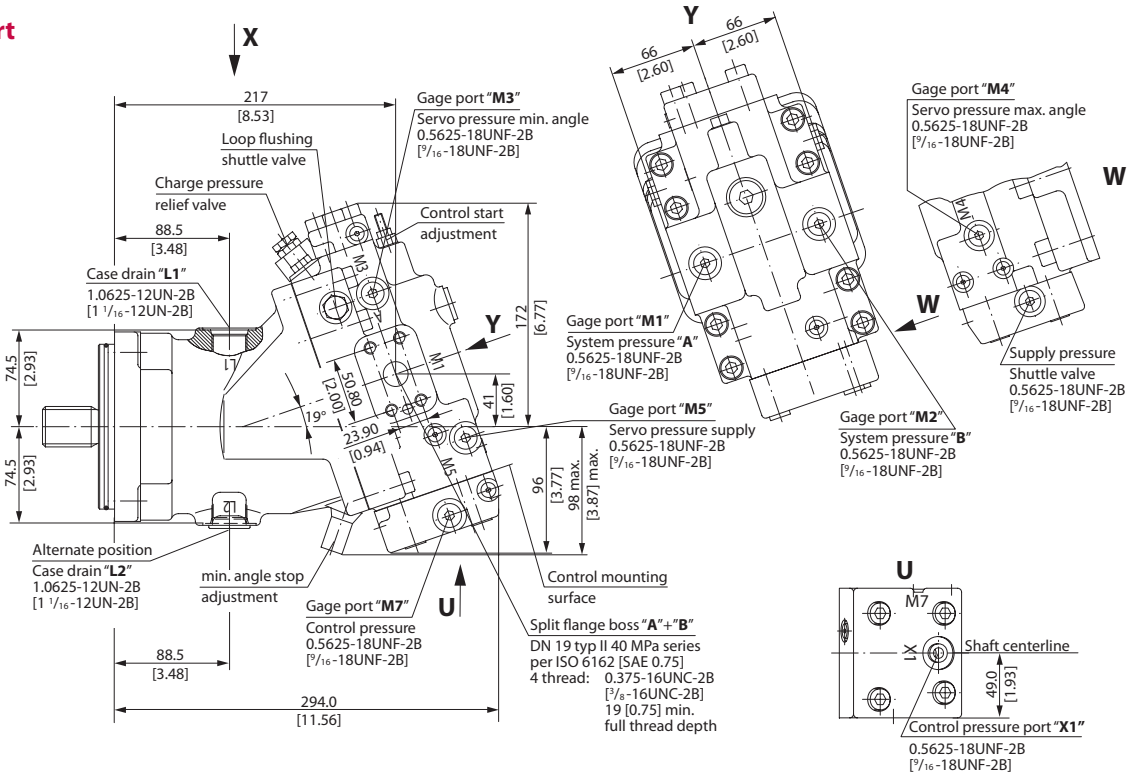

Axial Port

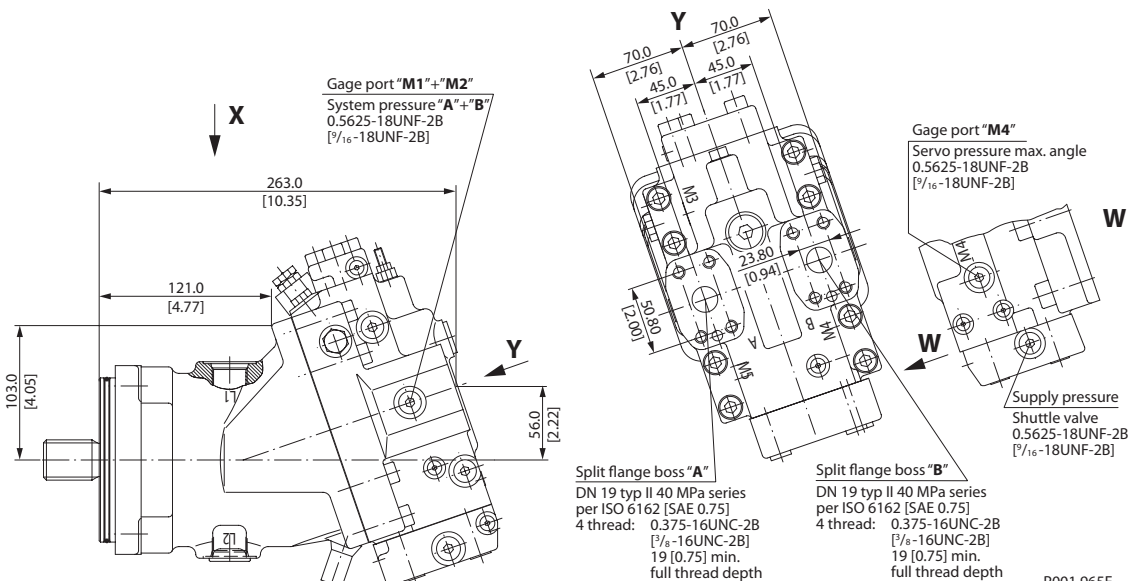

P001 965E

SAE FLANGE DESIGN
 PER ISO 3019/1
 (continued)

Shaft Options – 51V060-1 and 51V060

mm
 [in]

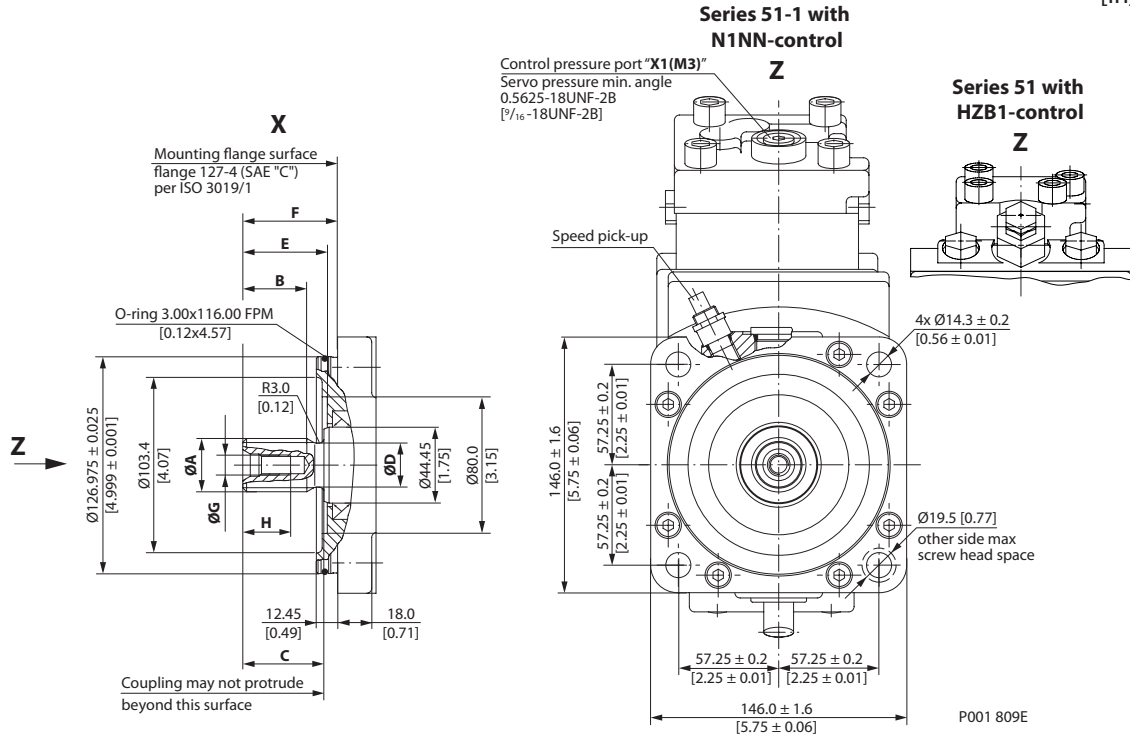

Shaft Spline Data				
Shaft option	S1		C6	
	mm	[in]	mm	[in]
Number of teeth	14		21	
Pitch	12/24		16/32	
Pressure angle	30°			
Spline	ANSI B92.1-1970 class 5 flat root side fit			
Pitch dia	29.633	[1.167]	33.337	[1.312]
Ø A	31.15	[1.23]	34.43	[1.36]
B	37.50	[1.48]	37.50	[1.48]
C	47.50±0.5	[1.87]	47.50±0.5	[1.87]
Ø D	25.80	[1.02]	30.00	[1.18]
E	50.30±1.2	[1.98]	50.30±1.2	[1.98]
F	55.50±0.7	[2.19]	55.50±0.7	[2.19]
Ø G	0.4375-14UNC-2B [7/16-14UNC-2B] allowed torque in thread max. 91 Nm [805 lbf·in]			
H	28.00	[1.10]	28.00	[1.10]

Flow into port **A** results in **CW** rotation of output shaft.
 Flow into port **B** results in **CCW** rotation of output shaft.
 Shaft rotation is determined by viewing from shaft end.
 Ports with O-ring seal and inch threads shall be in accordance with ISO 11926/1.
 Splite flange boss A and B per ISO 6162 is identical with high pressure series SAE J518 code 62 (6000 psi).
 Contact your Sauer-Danfoss representative for specific installation drawings.

**DIN FLANGE DESIGN
 PER ISO 3019/2**

51D060-1 Two Position Control, N1NN

mm
 [in]

Side Port

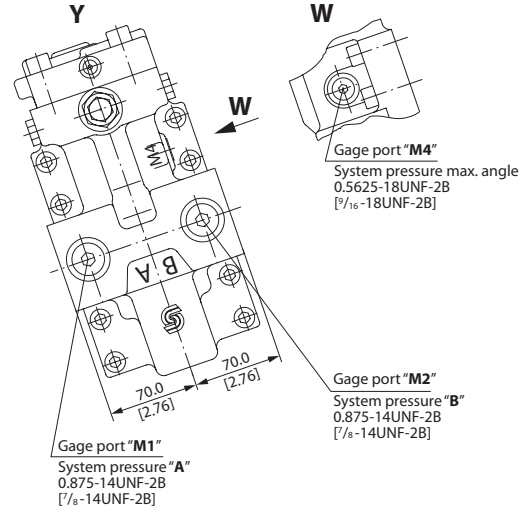
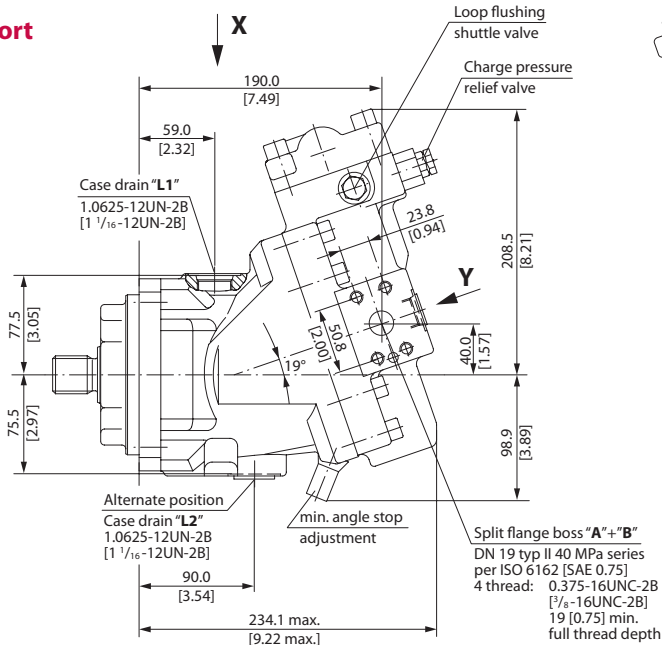

Axial Port

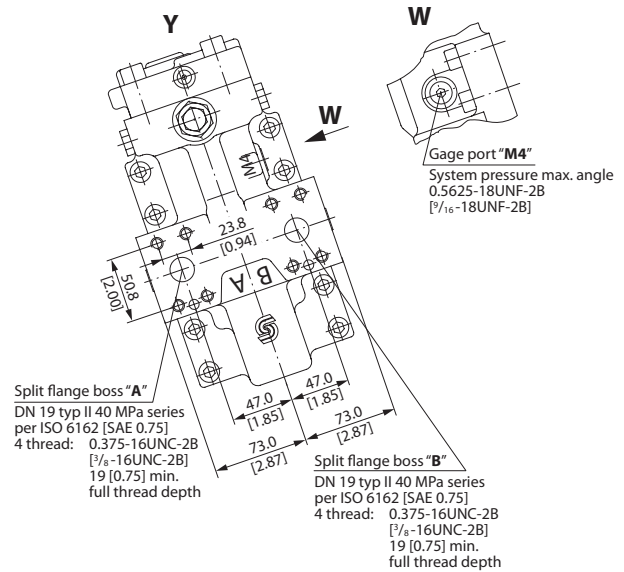
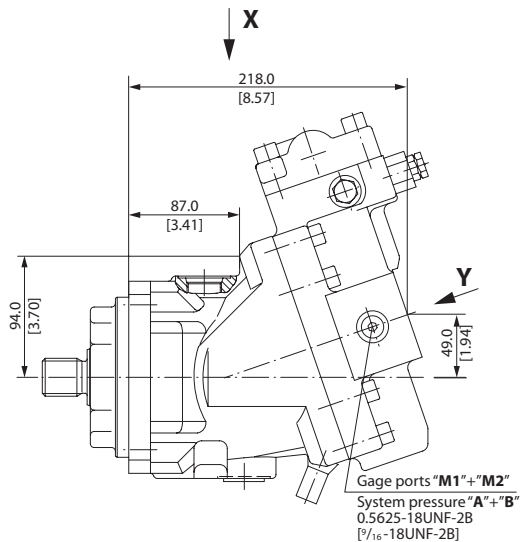

**DIN FLANGE DESIGN
 PER ISO 3019/2
 (continued)**

51D060 Proportional and Two Position Control, HZB1

mm
 [in]

Side Port

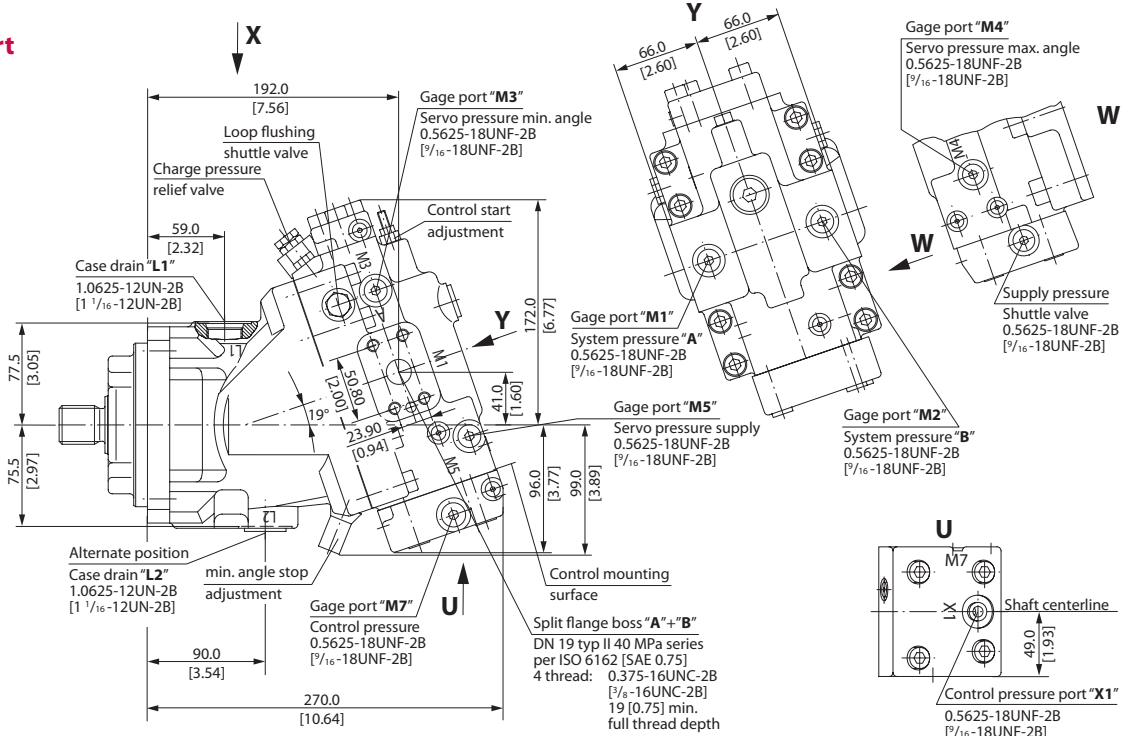

Axial Port

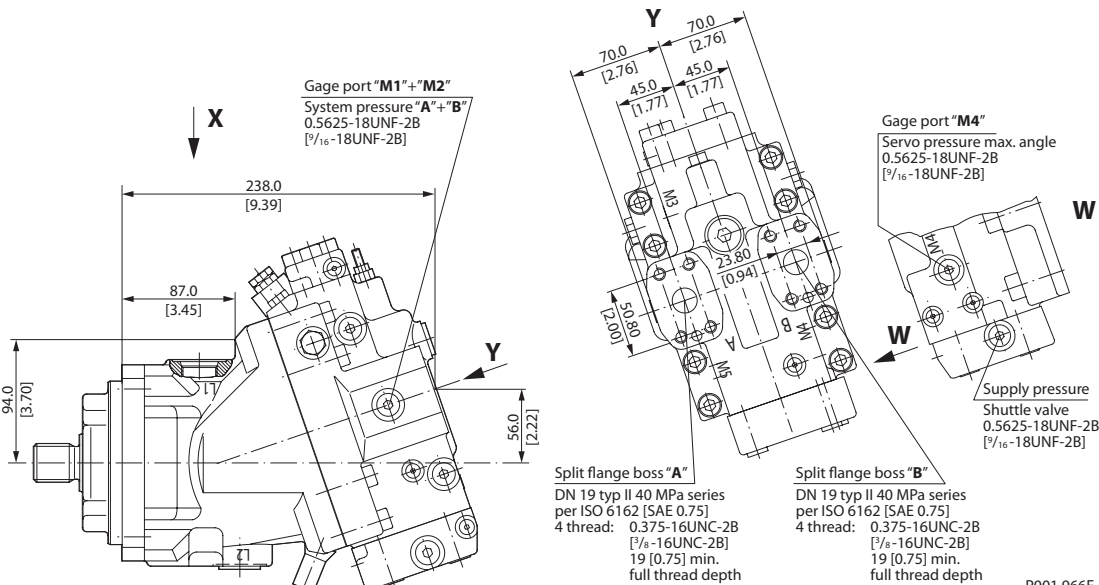

P001 966E

**DIN FLANGE DESIGN
 PER ISO 3019/2
 (continued)**

Shaft Options – 51D060-1 and 51D060

mm
 [in]

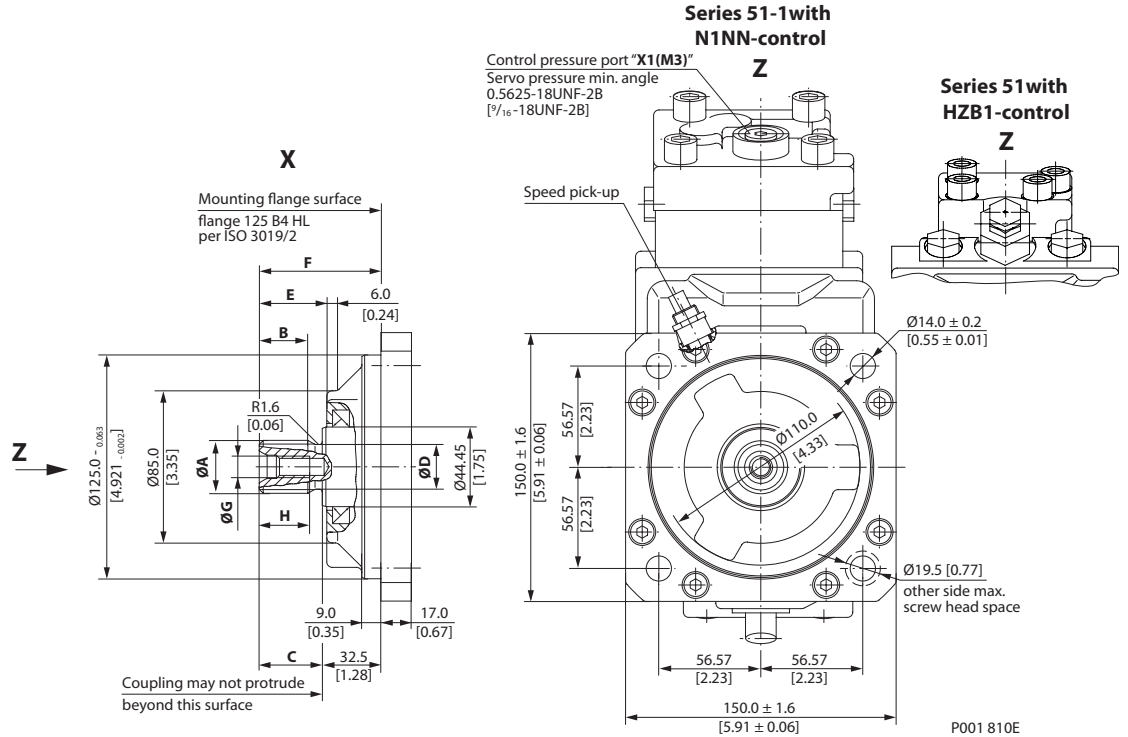

Shaft Spline Data				
Shaft option	D1		D2	
Dimension	mm	[in]	mm	[in]
Number of teeth	14		16	
Spline	W30x2x30x14x9g side fit DIN 5480		W35x2x30x16x9g side fit DIN 5480	
Pitch dia	28.000	[1.102]	32.000	[1.260]
Ø A	29.60	[1.17]	34.60	[1.36]
B	27.00	[1.06]	32.00	[1.28]
C	35.00±0.5	[1.38]	40.00±0.5	[1.58]
Ø D	25.00	[0.98]	30.00	[1.18]
E	37.50±1.1	[1.48]	42.50±1.1	[1.67]
F	67.50±0.6	[2.66]	72.50±0.6	[2.85]
Ø G	M10x1.5 allowed torque in thread max. 67 Nm [593 lbf·in]			
H	25.00	[0.98]	25.00	[0.98]

Flow into port **A** results in **CW** rotation of output shaft.
 Flow into port **B** results in **CCW** rotation of output shaft.
 Shaft rotation is determined by viewing from shaft end.
 Ports with O-ring seal and inch threads shall be in accordance with ISO 11926/1.
 Splite flange boss A and B per ISO 6162 is identical with high pressure series SAE J518 code 62 (6000 psi).
 Contact your Sauer-Danfoss representative for specific installation drawings.

CARTRIDGE FLANGE

51C060-1 Two Position Control, N1NN

mm
[in]

Side Port

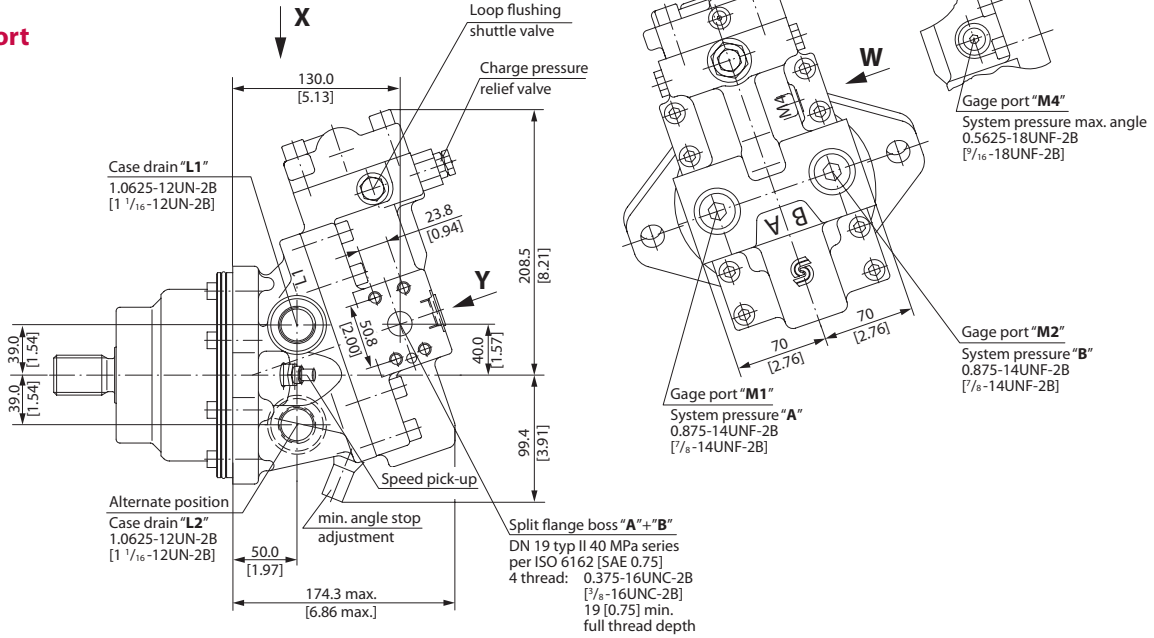

Axial Port

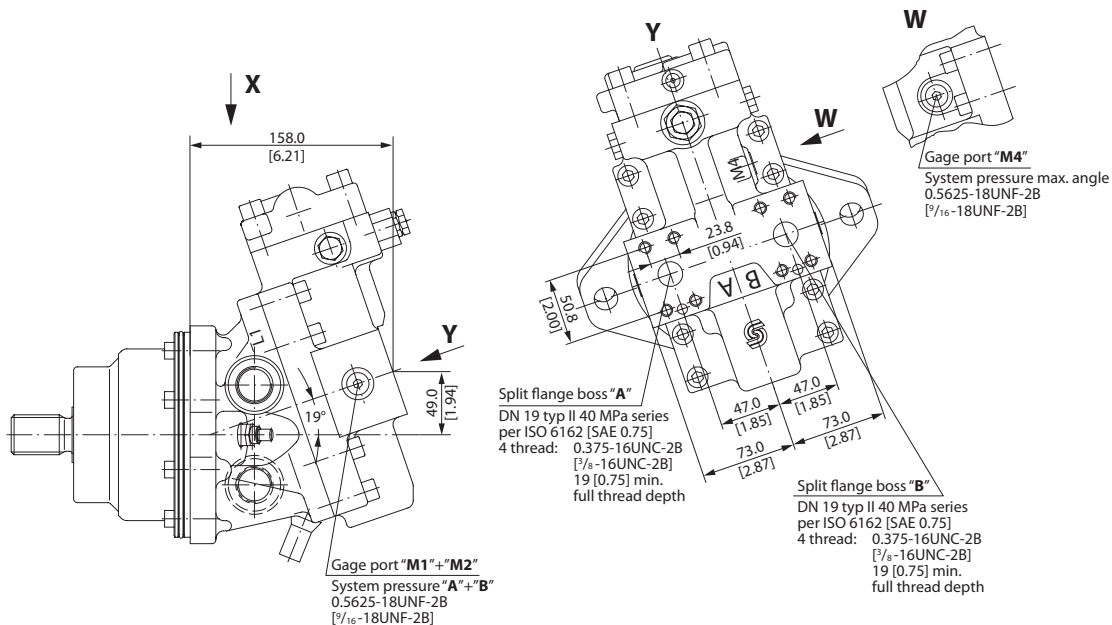

P001 792E

CARTRIDGE FLANGE
(continued)

51C060 Proportional and Two Position Control, HZB1

mm
[in]

Side Port

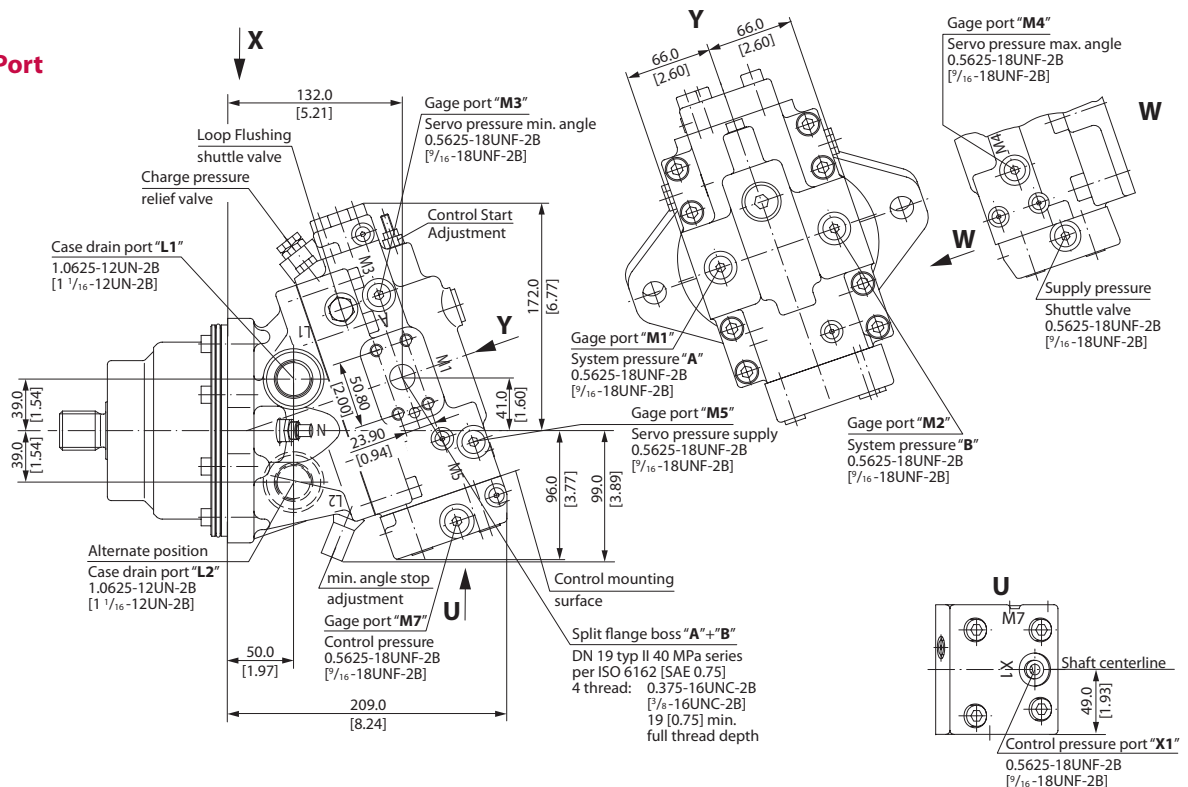

Axial Port

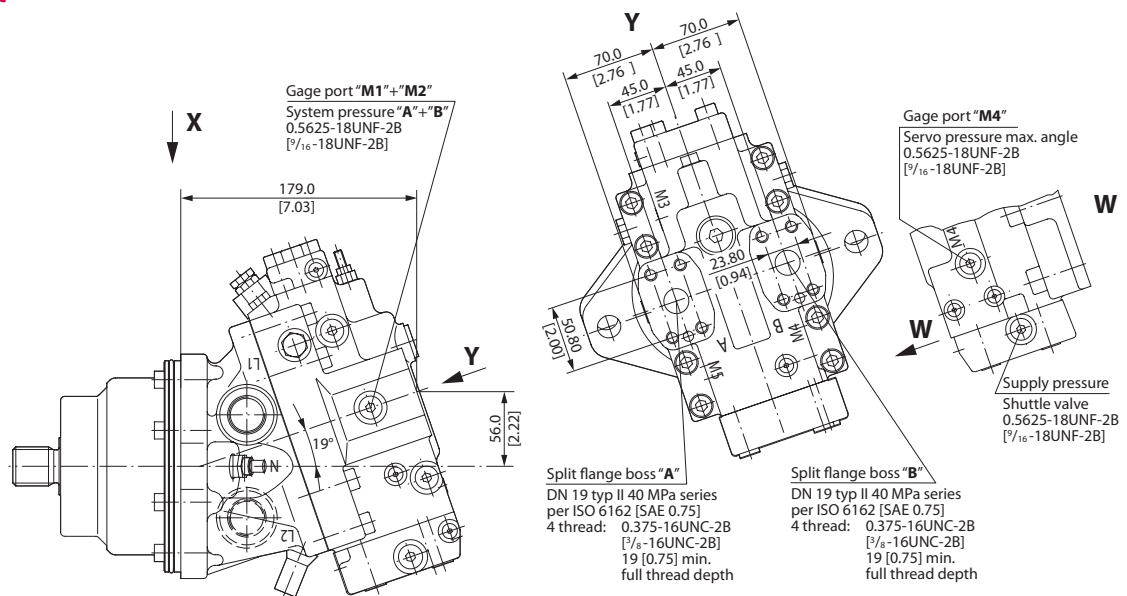

P001 967E

CARTRIDGE FLANGE
 (continued)

Shaft Options – 51C060-1 and 51C060

mm
 [in]

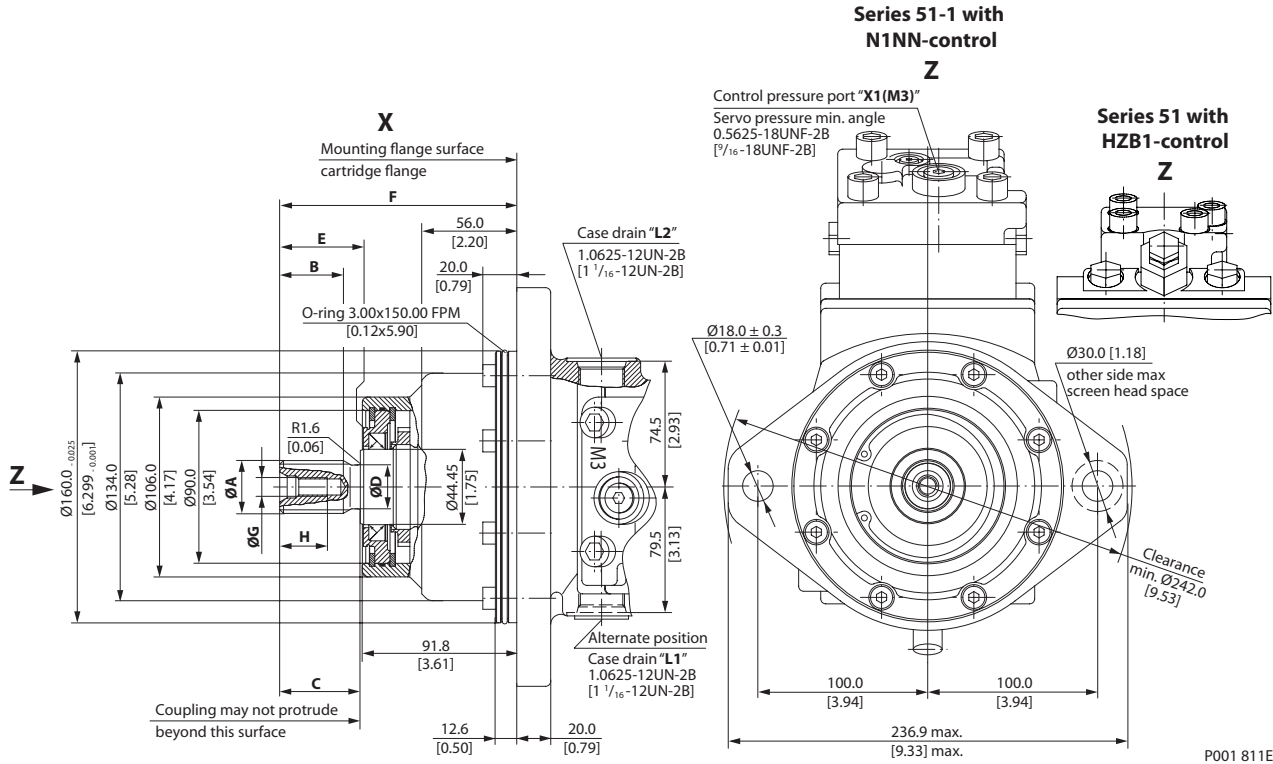

P001 811E

Shaft Spline Data				
Shaft option	D1		D2	
Dimension	mm	[in]	mm	[in]
Number of teeth	14		16	
Spline	W30x2x30x14x9g side fit DIN 5480		W35x2x30x16x9g side fit DIN 5480	
Pitch dia	28.000	[1.102]	32.000	[1.260]
Ø A	29.60	[1.17]	34.60	[1.36]
B	27.00	[1.06]	32.00	[1.28]
C	35.00±0.5	[1.38]	40.00±0.5	[1.58]
Ø D	25.00	[0.98]	30.00	[1.18]
E	36.80±1.4	[1.45]	41.80±1.4	[1.65]
F	127.20±0.6	[5.00]	132.20±0.6	[5.21]
Ø G	M10x1.5 allowed torque in thread max. 67 Nm [593 lbf·in]			
H	25.00	[0.98]	25.00	[0.98]

Flow into port **A** results in **CW** rotation of output shaft.
 Flow into port **B** results in **CCW** rotation of output shaft.
 Shaft rotation is determined by viewing from shaft end.
 Ports with O-ring seal and inch threads shall be in accordance with ISO 11926/1.
 Splite flange boss A and B per ISO 6162 is identical with high pressure series SAER J518 code 62 (6000 psi).
 Contact your Sauer-Danfoss representative for specific installation drawings.

**SAE FLANGE DESIGN
 PER ISO 3019/1**

51V080-1 Two Position Control, N1NN

mm
 [in]

Side Port

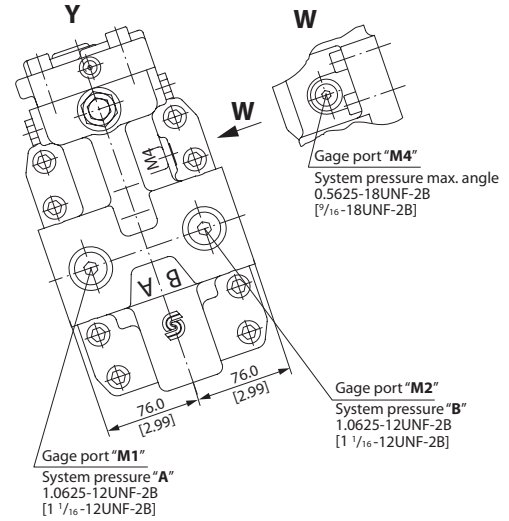
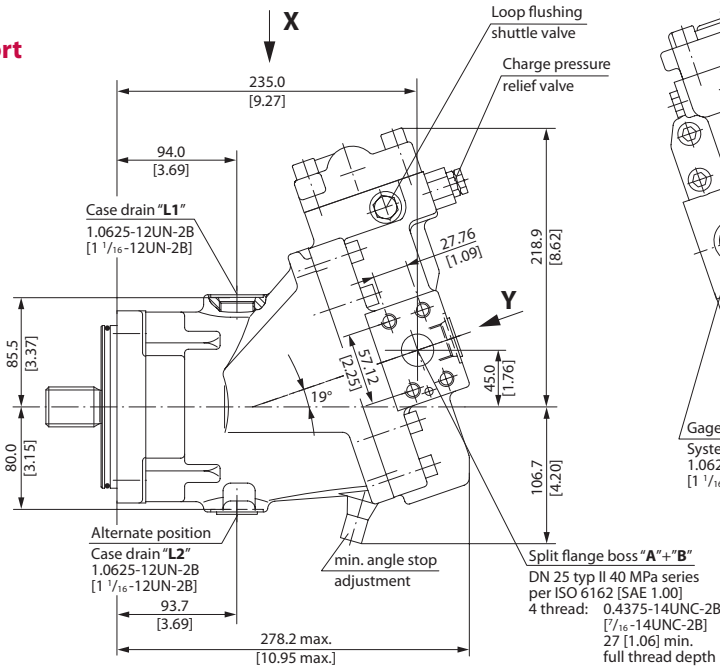

Axial Port

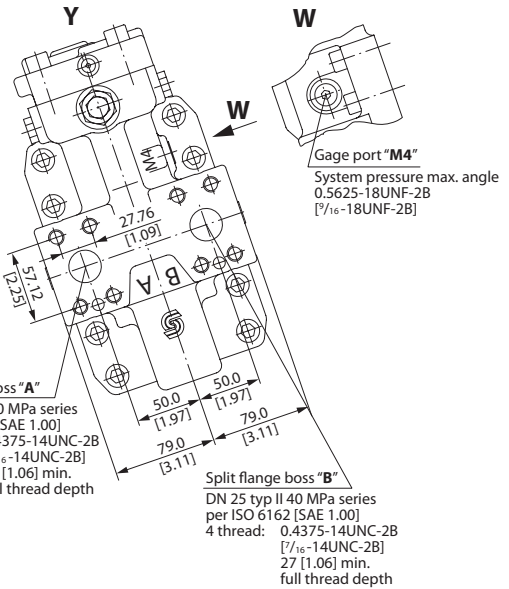
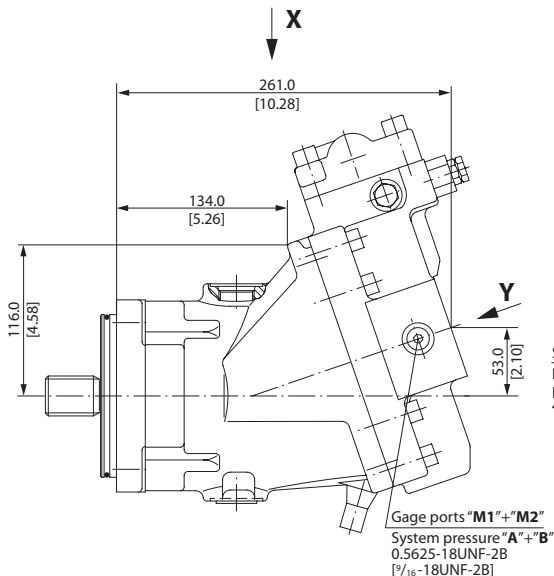

P001 793E

**SAE FLANGE DESIGN
 PER ISO 3019/1
 (continued)**

51V080 Proportional and Two-Position Control, HZB1

mm
 [in]

Side Port

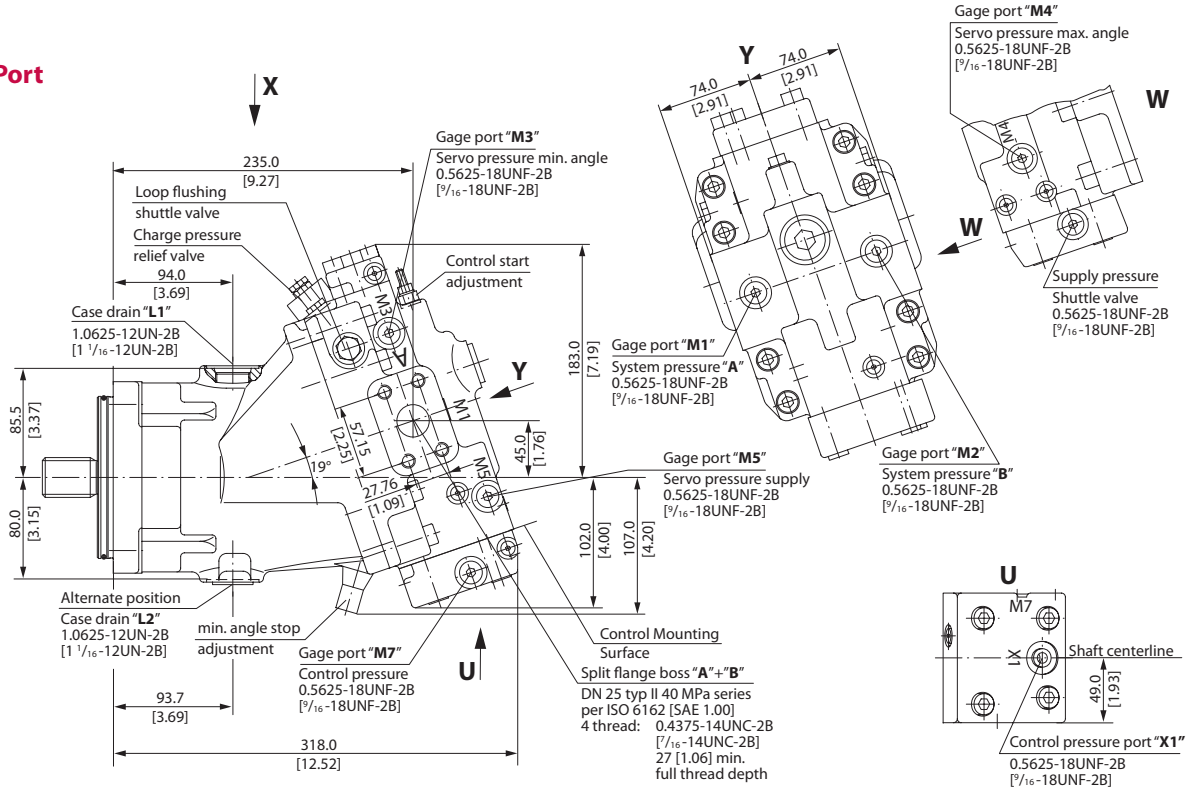

Axial Port

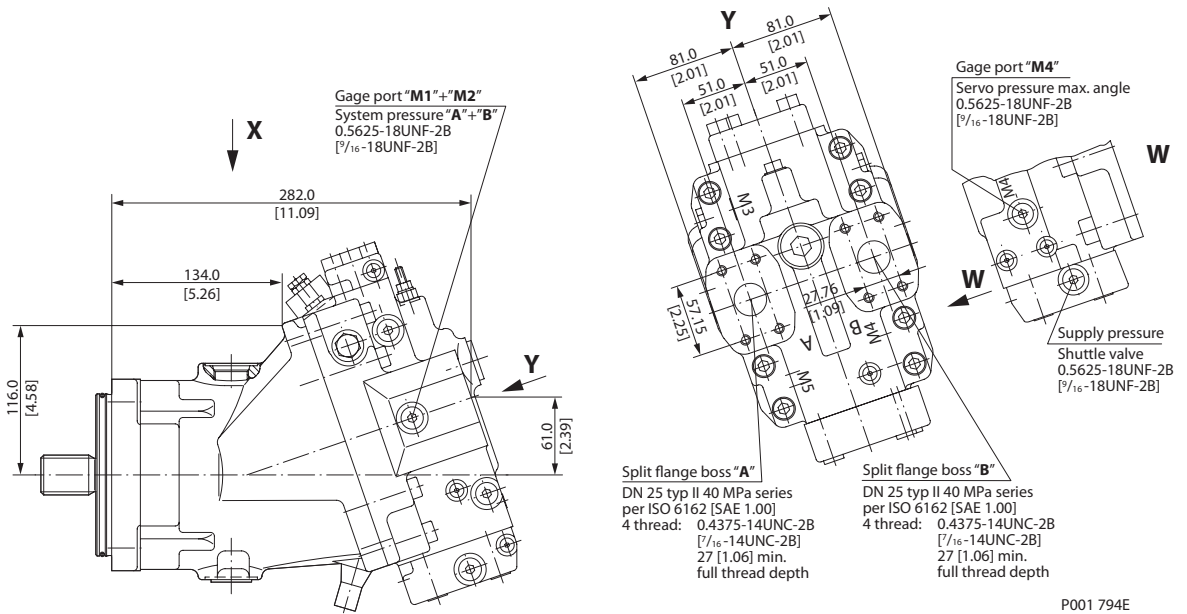

P001 794E

SAE FLANGE DESIGN
 PER ISO 3019/1
 (continued)

Shaft Options – 51V080-1 and 51V080

mm
 [in]

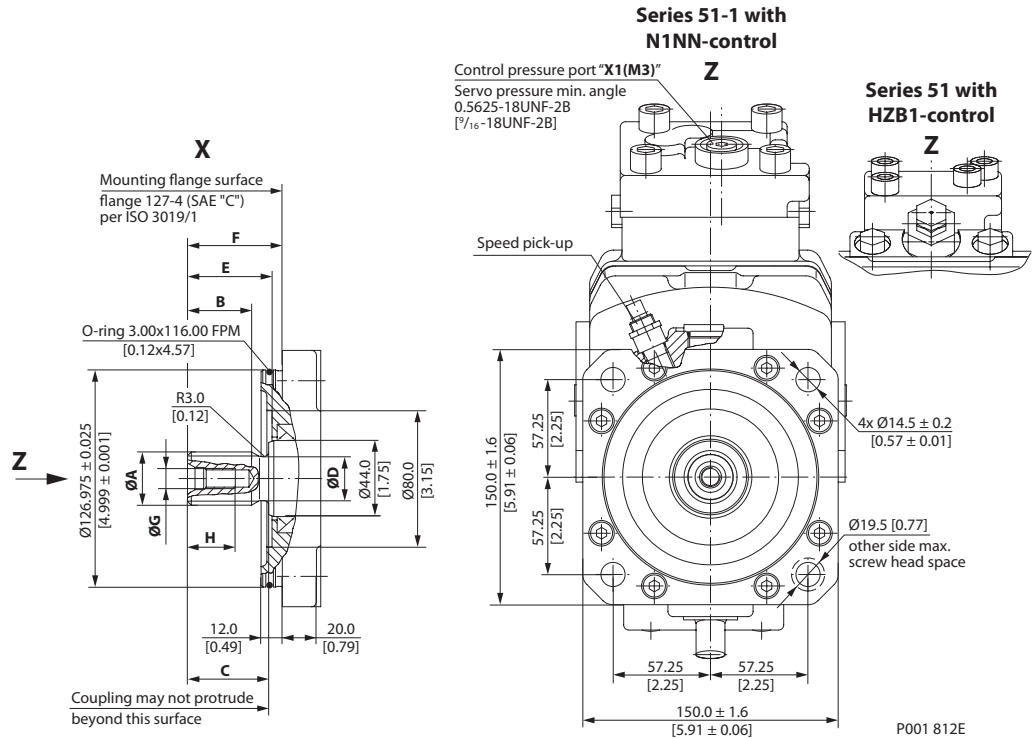

Shaft Spline Data				
Shaft option	S1		C7	
Dimension	mm	[in]	mm	[in]
Number of teeth	14		23	
Pitch	12/24		16/32	
Pressure angle	30°			
Spline	ANSI B92.1-1970 class 5 flat root side fit			
Pitch dia	29.633	[1.167]	36.513	[1.438]
\varnothing A	31.15	[1.23]	37.61	[1.48]
B	37.50	[1.48]	37.50	[1.48]
C	47.50 \pm 0.5	[1.87]	47.50 \pm 0.5	[1.87]
\varnothing D	25.80	[1.02]	32.00	[1.26]
E	49.50 \pm 1.1	[1.95]	49.50 \pm 1.1	[1.95]
F	55.50 \pm 0.7	[2.19]	55.50 \pm 0.7	[2.19]
\varnothing G	0.4375-14UNC-2B [7/16-14UNC-2B] allowed torque in thread max. 91 Nm [805 lbf·in]			
H	28.00	[1.10]	28.00	[1.10]

Flow into port **A** results in **CW** rotation of output shaft.
 Flow into port **B** results in **CCW** rotation of output shaft.
 Shaft rotation is determined by viewing from shaft end.
 Ports with O-ring seal and inch threads shall be in accordance with ISO 11926/1.
 Split flange boss A and B per ISO 6162 is identical with high pressure series SAE J518 code 62 (6000 psi).
 Contact your Sauer-Danfoss representative for specific installation drawings.

**DIN FLANGE DESIGN
 PER ISO 3019/2**

51D080-1 Two Position Control, N1NN

mm
 [in]

Side Port

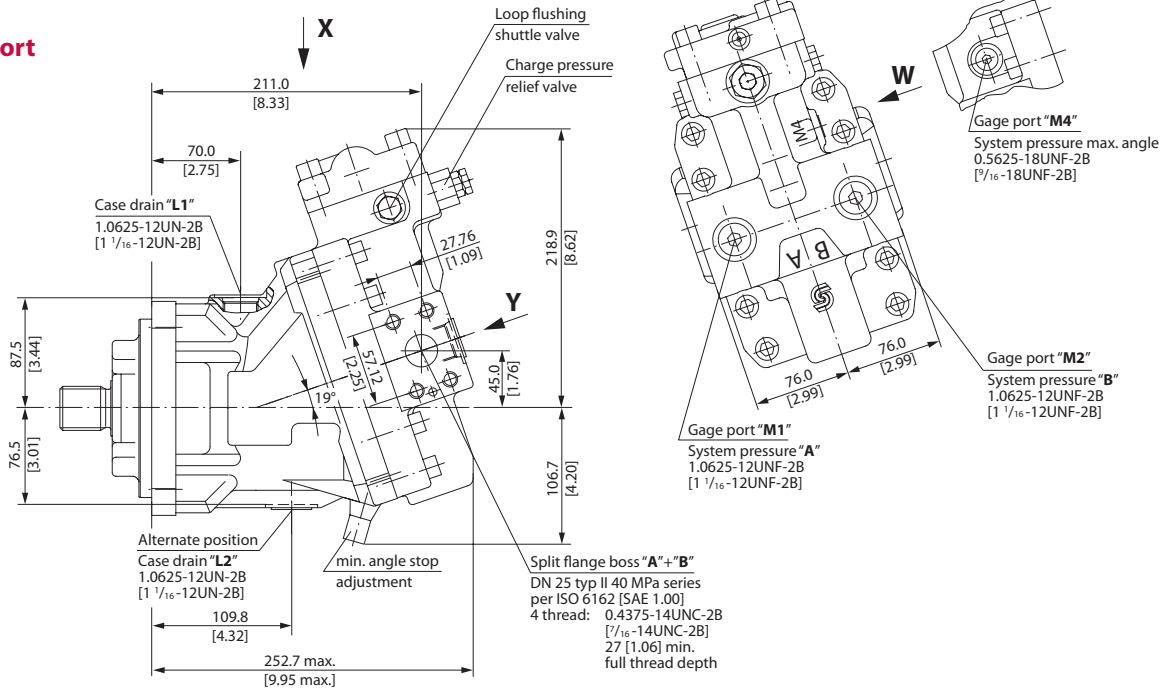

Axial Port

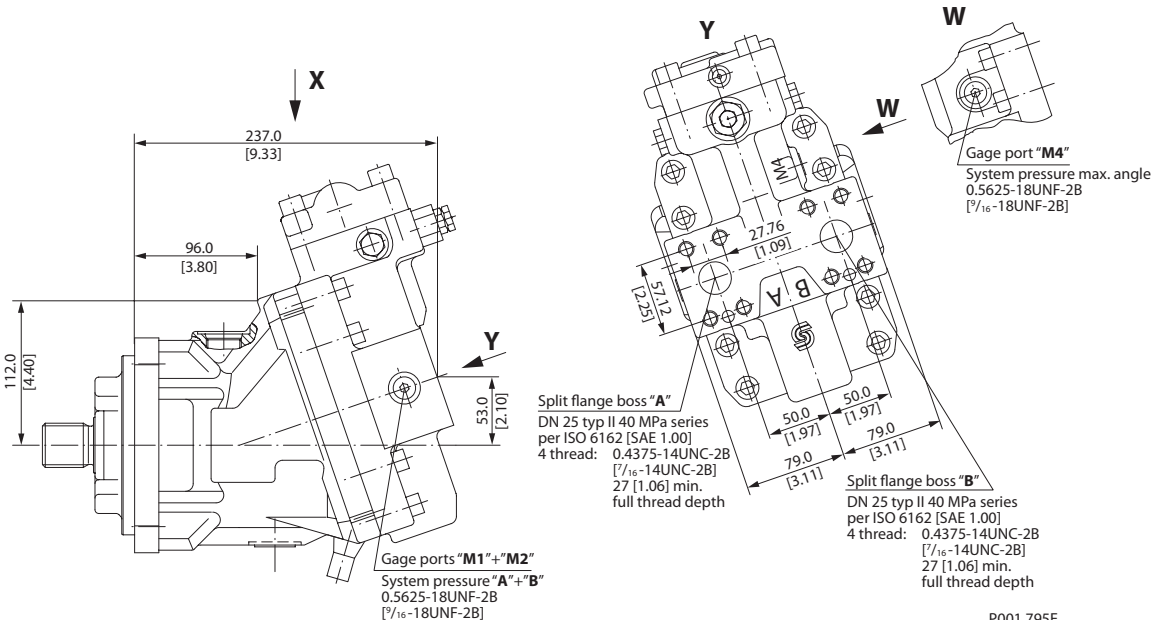

P001 795E

DIN FLANGE DESIGN
PER ISO 3019/2
(continued)

51D080 Proportional and Two-Position Control, HZB1

mm
 [in]

Side Port

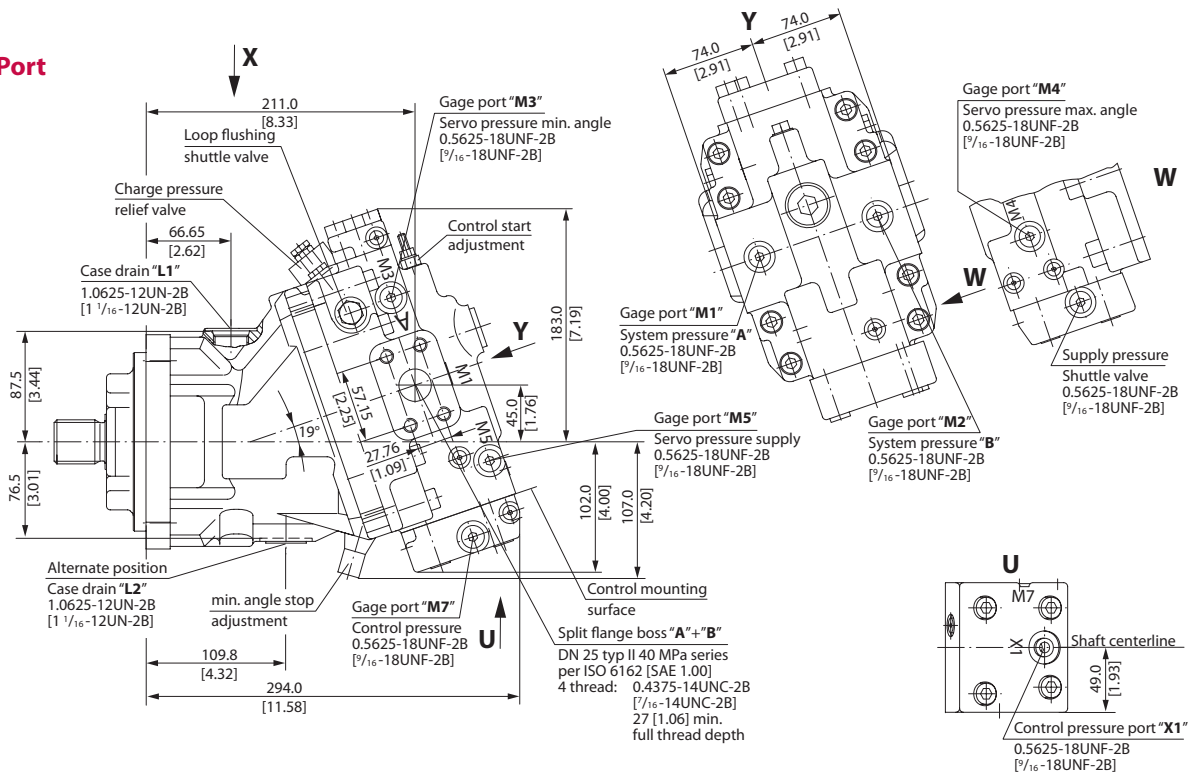

Axial Port

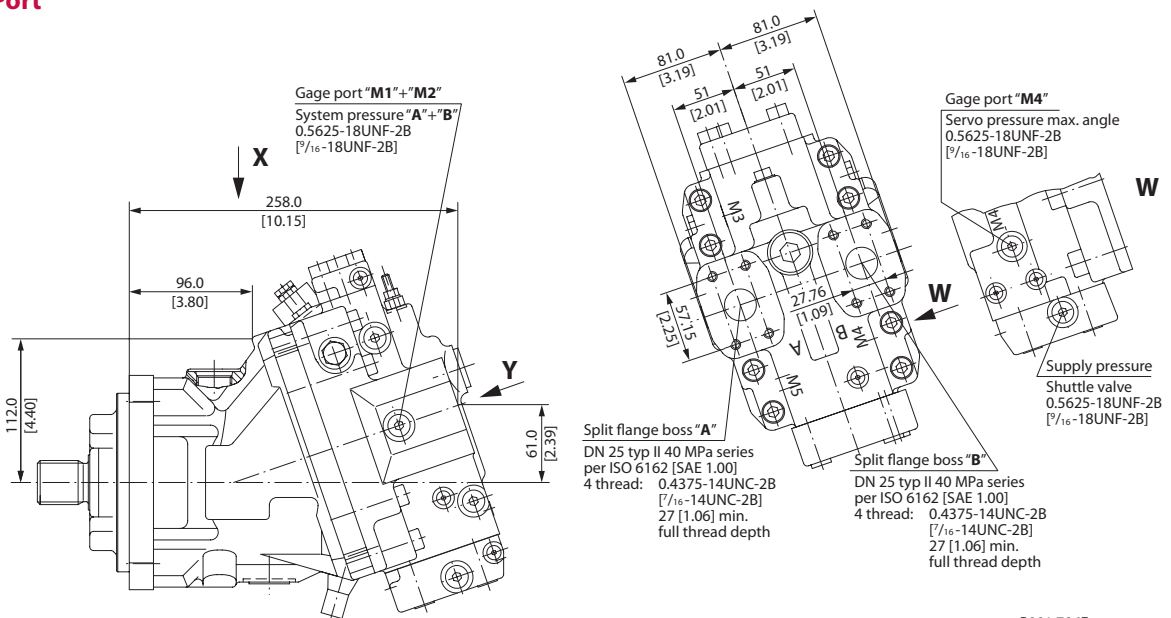

P001 796E

DIN FLANGE DESIGN
 PER ISO 3019/2
 (continued)

Shaft Options – 51D080-1 and 51D080

mm
 [in]

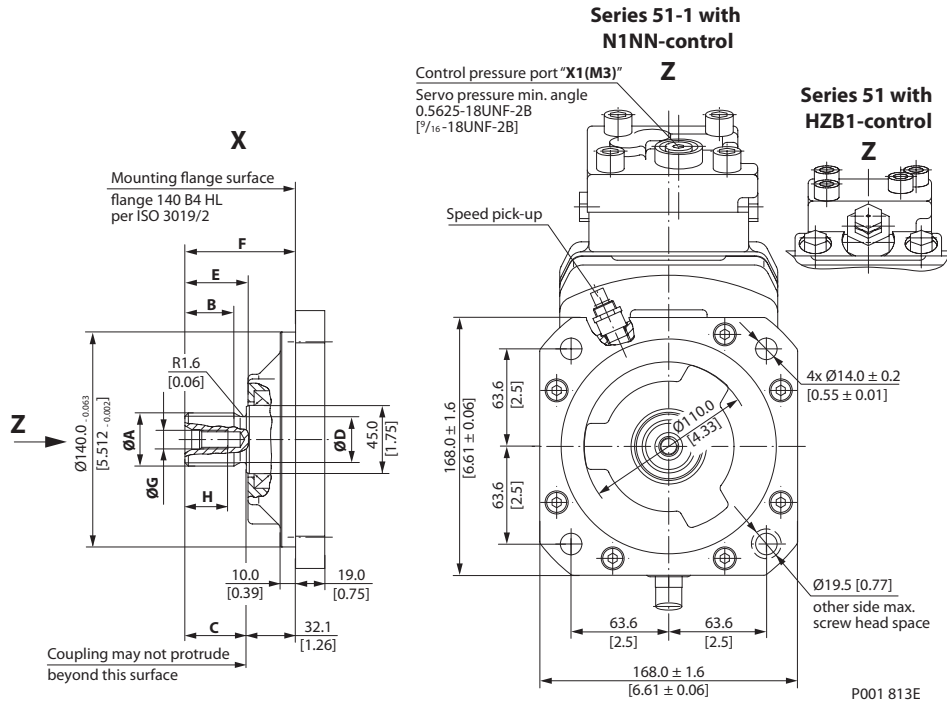

Shaft Spline Data			
Shaft option	D2		D3
Dimension	mm	[in]	mm [in]
Number of teeth	16		18
Spline	W35x2x30x16x9g side fit DIN 5480		W40x2x30x18x9g side fit DIN 5480
Pitch dia	32.000	[1.260]	36.000 [1.417]
Ø A	34.60	[1.36]	39.60 [1.56]
B	32.00	[1.28]	37.00 [1.46]
C	40.00±0.5	[1.58]	45.00±0.5 [1.77]
Ø D	30.00	[1.18]	35.00 [1.38]
E	41.10±1.1	[1.62]	45.10±1.1 [1.82]
F	72.10±0.6	[2.84]	77.10±0.6 [3.04]
Ø G	M10x1.5 allowed torque in thread max. 67 Nm [593 lbf·in]		
H	25.00	[0.98]	25.00 [0.98]

Flow into port **A** results in **CW** rotation of output shaft.
 Flow into port **B** results in **CCW** rotation of output shaft.
 Shaft rotation is determined by viewing from shaft end.
 Ports with O-ring seal and inch threads shall be in accordance with ISO 11926/1.
 Splite flange boss A and B per ISO 6162 is identical with high pressure series SAE J518 code 62 (6000 psi).
 Contact your Sauer-Danfoss representative for specific installation drawings.

CARTRIDGE FLANGE

51C080-1 Two Position Control, N1NN

mm
[in]

Side Port

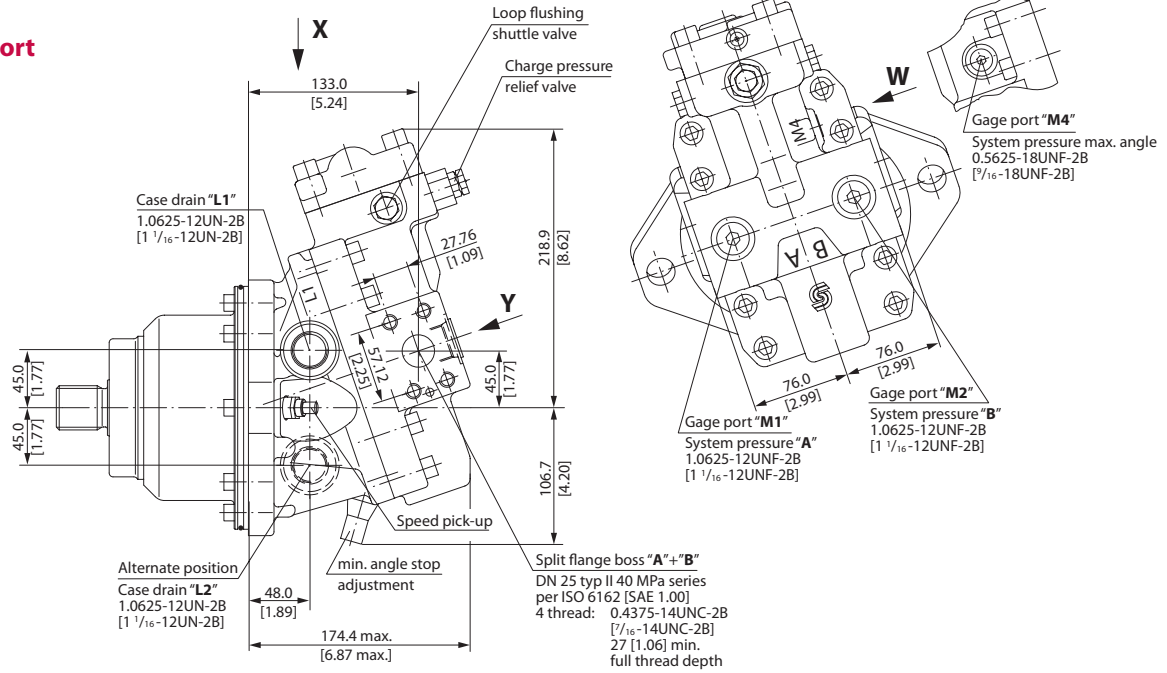

Axial Port

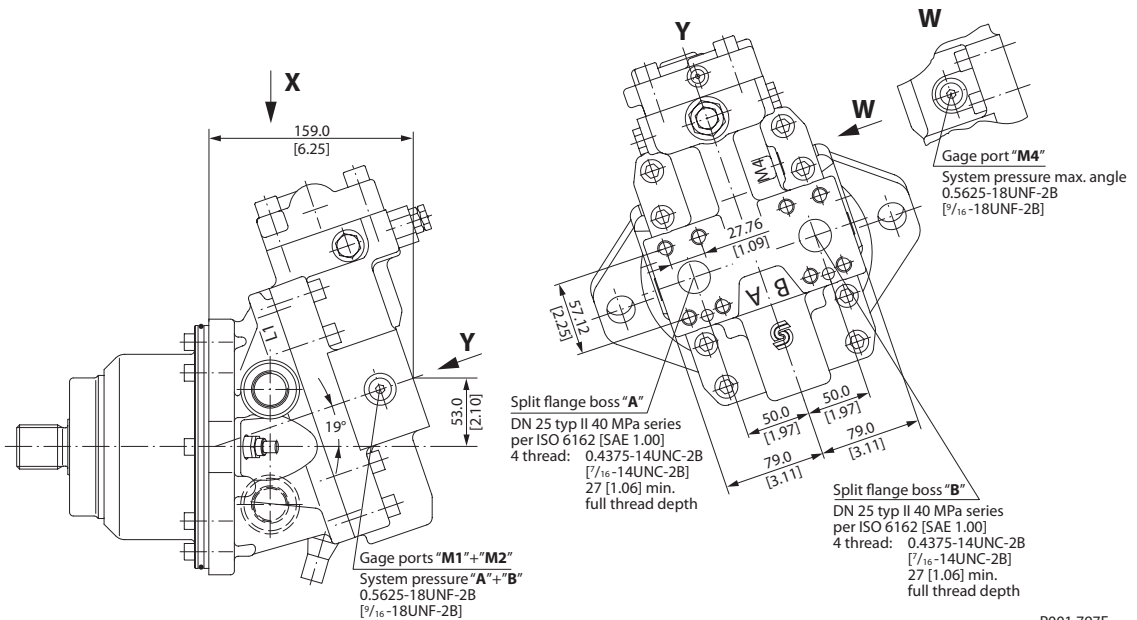

P001 797E

CARTRIDGE FLANGE
 (continued)

51C080 Proportional and Two-Position Control, HZB1

mm
 [in]

Side Port

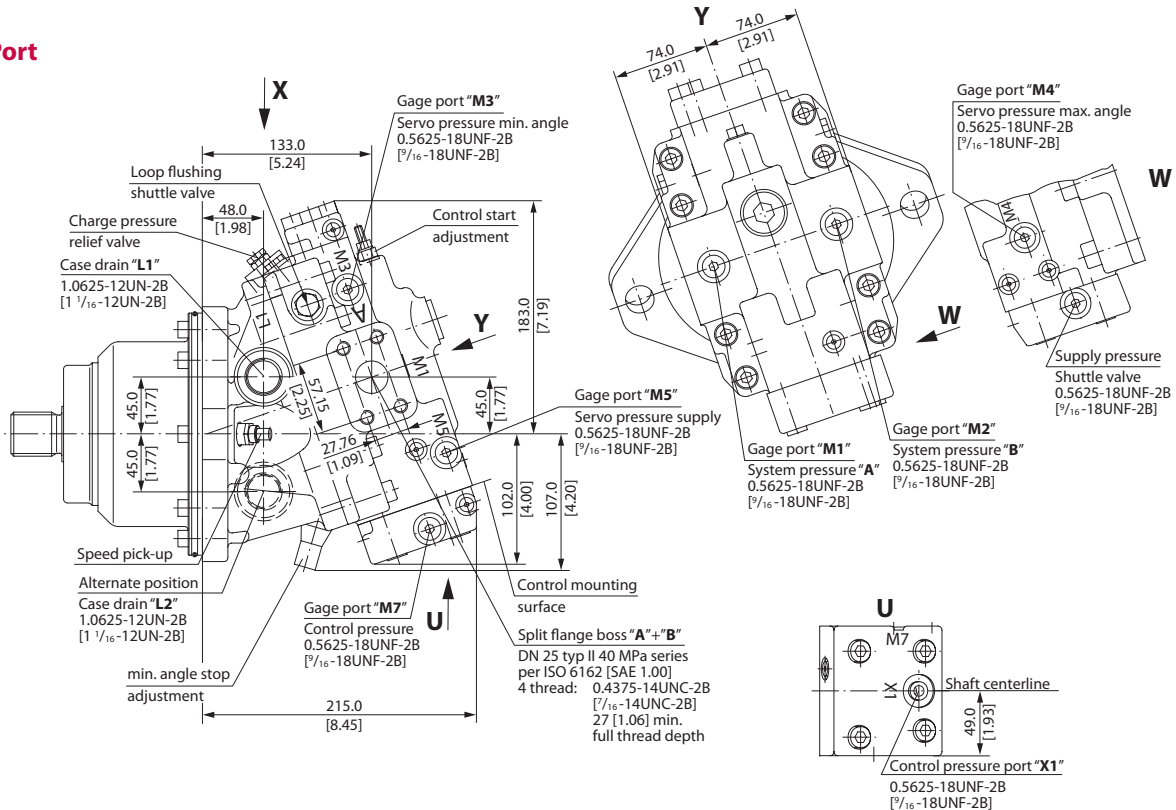

Axial Port

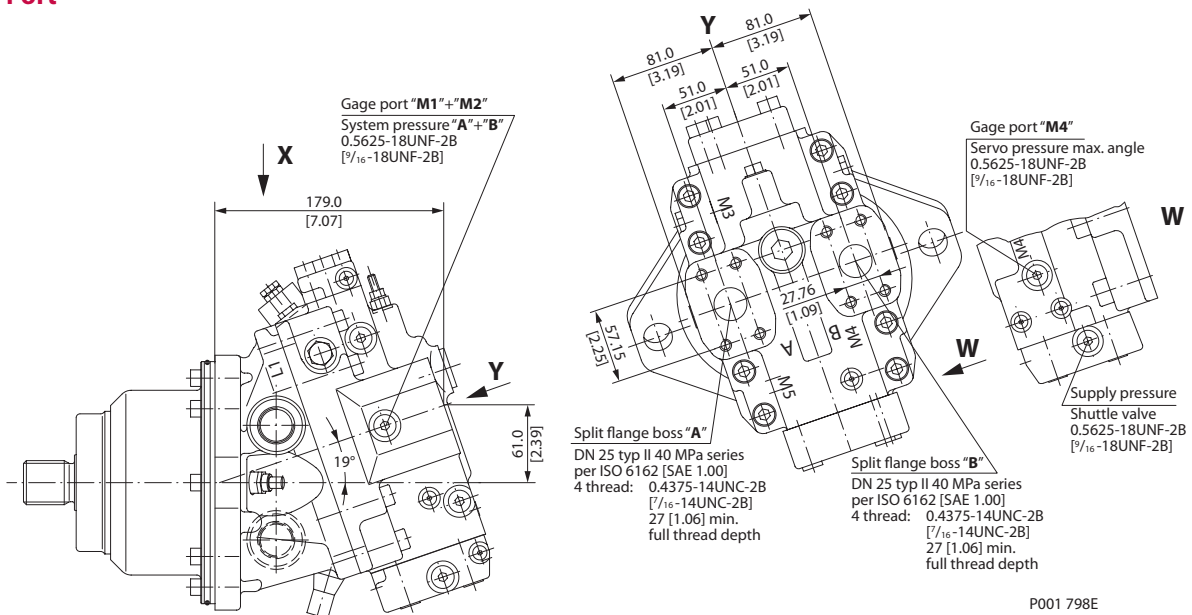

P001 798E

CARTRIDGE FLANGE
 (continued)

Shaft Options – 51C080-1 and 51C080

mm
 [in]

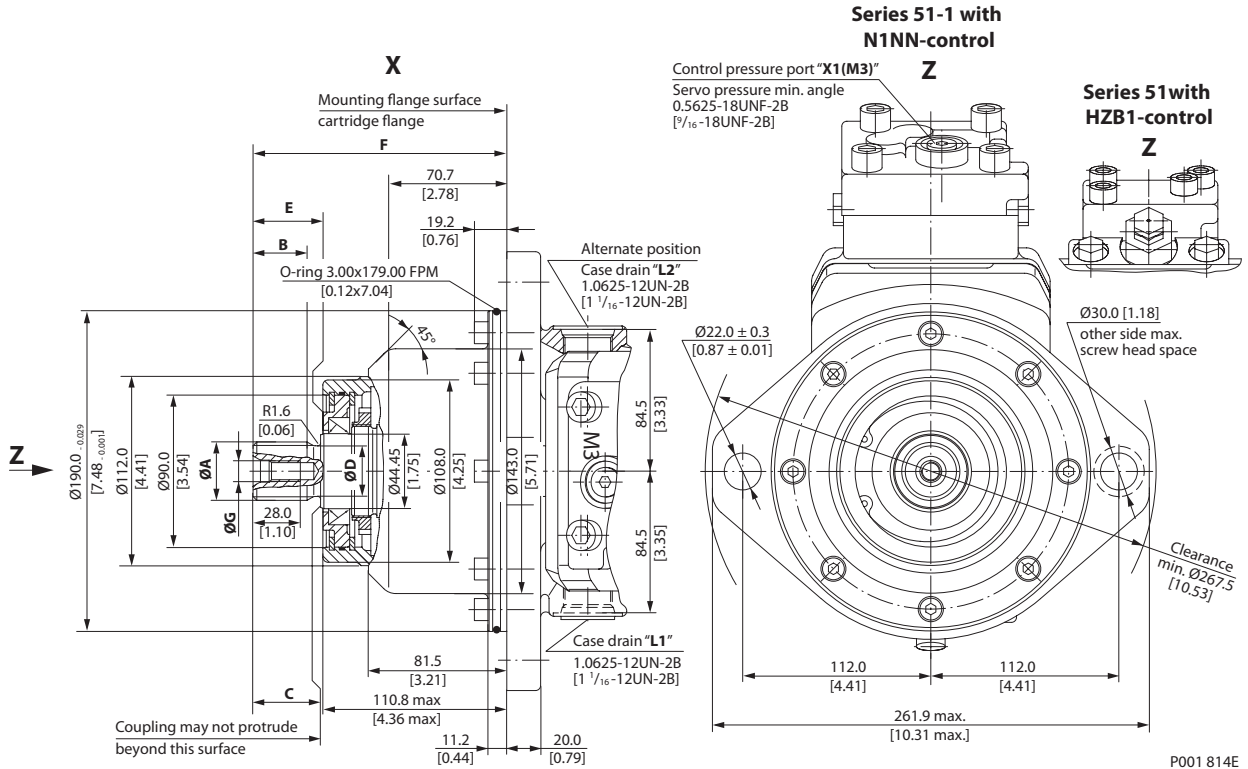

P001 814E

Shaft Spline Data				
Shaft option	D2		D3	
Dimension	mm	[in]	mm	[in]
Number of teeth	16		18	
Spline	W35x2x30x16x9g side fit DIN 5480		W40x2x30x18x9g side fit DIN 5480	
Pitch dia	32.000	[1.260]	36.000	[1.417]
Ø A	34.60	[1.36]	39.60	[1.56]
B	32.00	[1.28]	37.00	[1.46]
C	40.00±0.5	[1.58]	45.00±0.5	[1.77]
Ø D	30.00	[1.18]	35.00	[1.38]
E	41.55±1.4	[1.64]	46.55±1.4	[1.83]
F	150.40±0.6	[5.92]	155.40±0.6	[6.12]
Ø G	M10x1.5 allowed torque in thread max. 67 Nm [593 lbf·in]			
H	25.00	[0.98]	25.00	[0.98]

Flow into port **A** results in **CW** rotation of output shaft.
 Flow into port **B** results in **CCW** rotation of output shaft.
 Shaft rotation is determined by viewing from shaft end.
 Ports with O-ring seal and inch threads shall be in accordance with ISO 11926/1.
 Split flange boss A and B per ISO 6162 is identical with high pressure series SAE J518 code 62 (6000 psi).
 Contact your Sauer-Danfoss representative for specific installation drawings.

**SAE FLANGE DESIGN
 PER ISO 3019/1**

51V110-1 Two Position Control, N1NN

mm
 [in]

Side Port

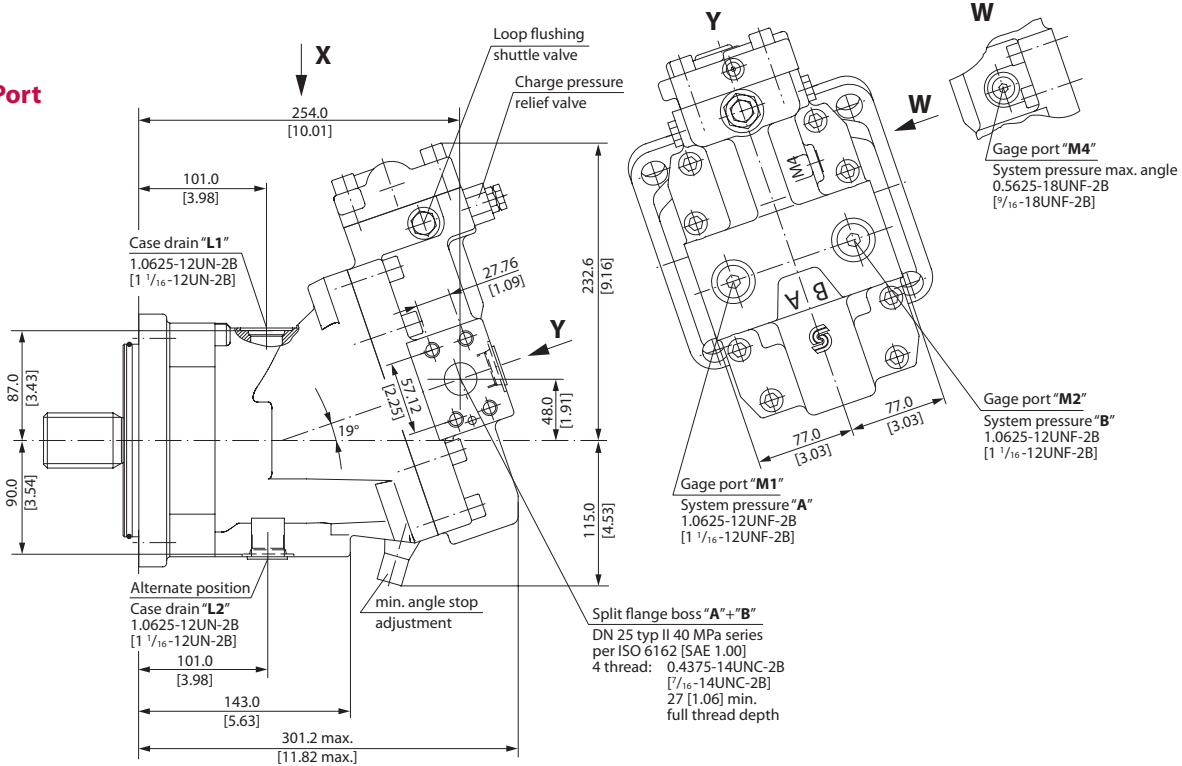

Axial Port

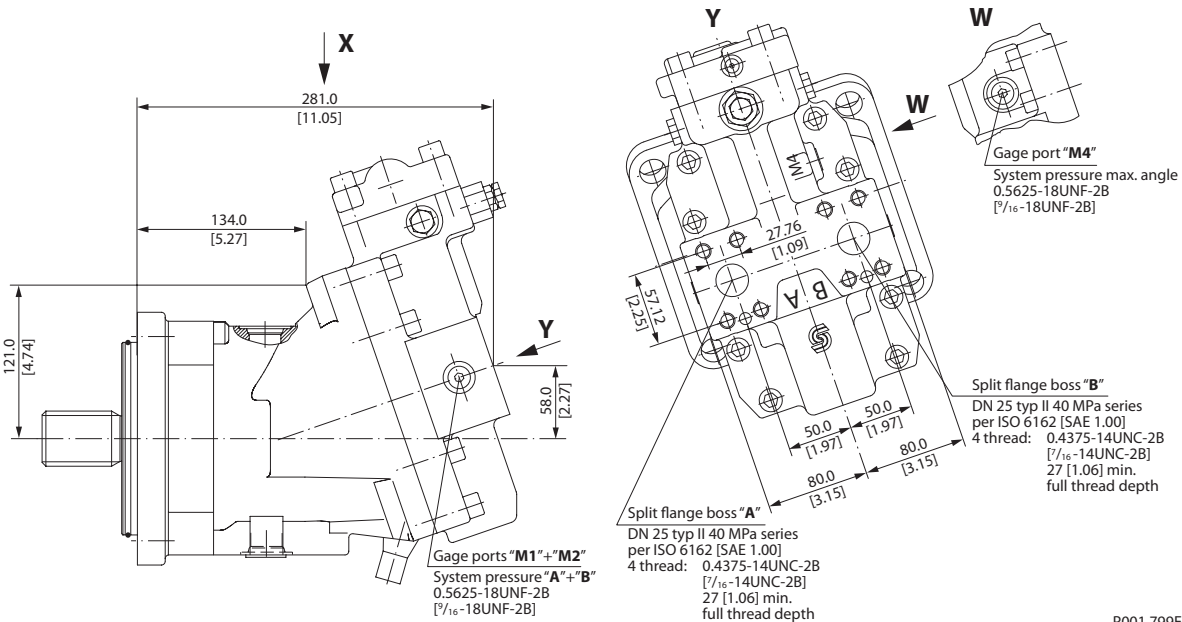

**SAE FLANGE DESIGN
 PER ISO 3019/1
 (continued)**

51V110 Proportional and Two-Position Control, HZB1

mm
 [in]

Side Port

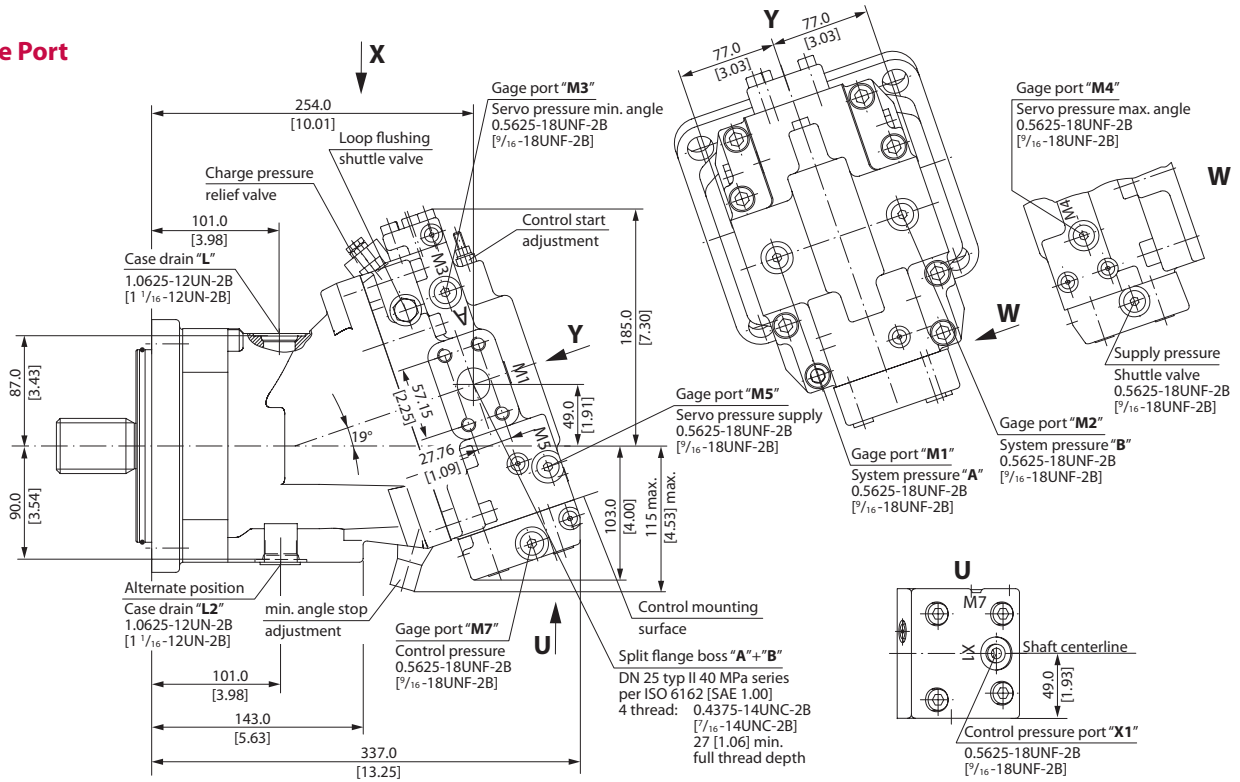

Axial Port

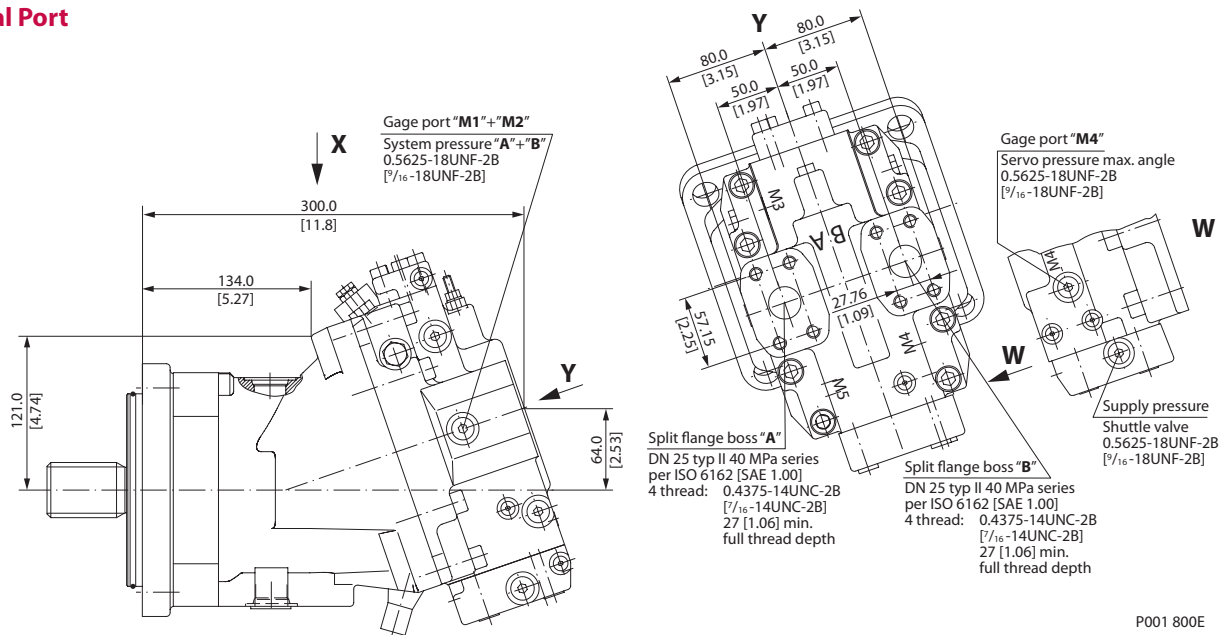

P001 800E

SAE FLANGE DESIGN
 PER ISO 3019/1
 (continued)

Shaft Options – 51V110-1 and 51V110

mm
 [in]

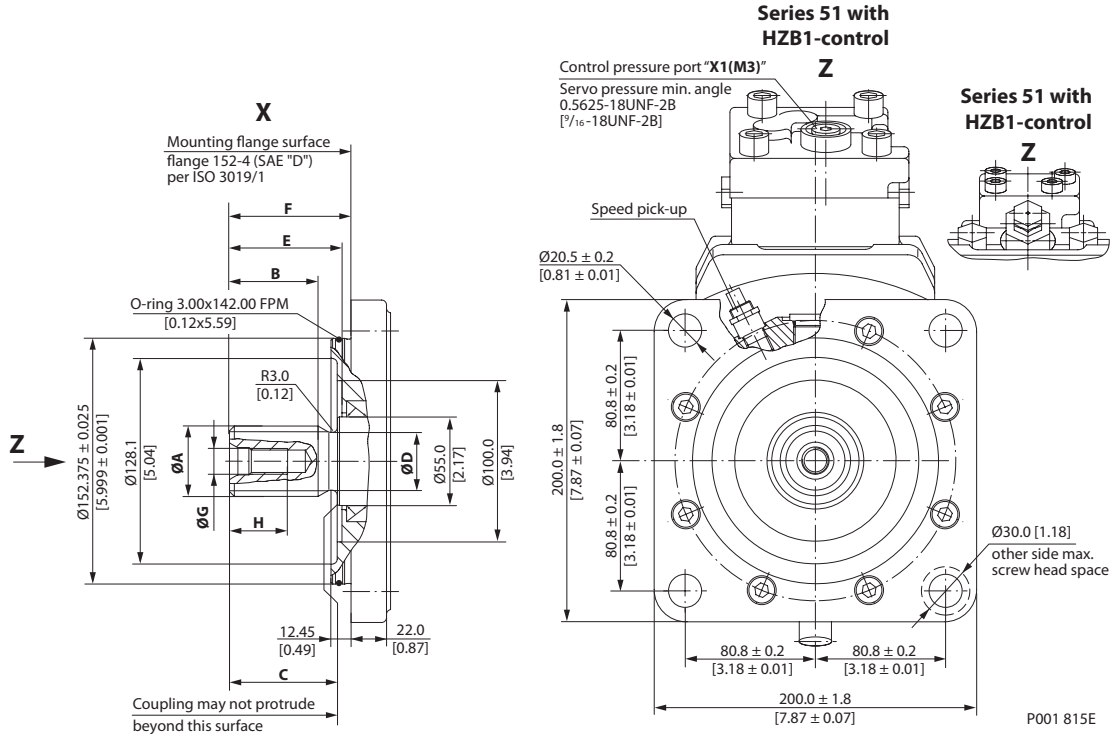

Shaft Spline Data				
Shaft option	F1		C8	
Dimension	mm	[in]	mm	[in]
Number of teeth	13		27	
Pitch	8/16		16/32	
Pressure angle	30°			
Spline	ANSI B92.1-1970 class 5 flat root side fit			
Pitch dia	41.275	[1.625]	42.862	[1.688]
∅ A	43.64	[1.72]	43.96	[1.73]
B	55.00	[2.17]	55.00	[2.17]
C	67.00±0.5	[2.64]	67.00±0.5	[2.64]
∅ D	36.00	[1.42]	39.60	[1.56]
E	69.80±1.1	[2.75]	69.80±1.1	[2.75]
F	75.40±0.7	[2.97]	75.40±0.7	[2.97]
∅ G	0.625-11UNC-2B [5/8-11UNC-2B] allowed torque in thread max. 200 Nm [1770 lbf·in]			
H	36.00	[1.42]	36.00	[1.42]

Flow into port **A** results in **CW** rotation of output shaft.
 Flow into port **B** results in **CCW** rotation of output shaft.
 Shaft rotation is determined by viewing from shaft end.
 Ports with O-ring seal and inch threads shall be in accordance with ISO 11926/1.
 Splite flange boss A and B per ISO 6162 is identical with high pressure series SAE J518 code 62 (6000 psi).
 Contact your Sauer-Danfoss representative for specific installation drawings.

**DIN FLANGE DESIGN
 PER ISO 3019/2**

51D110-1 Two Position Control, N1NN

mm
 [in]

Side Port

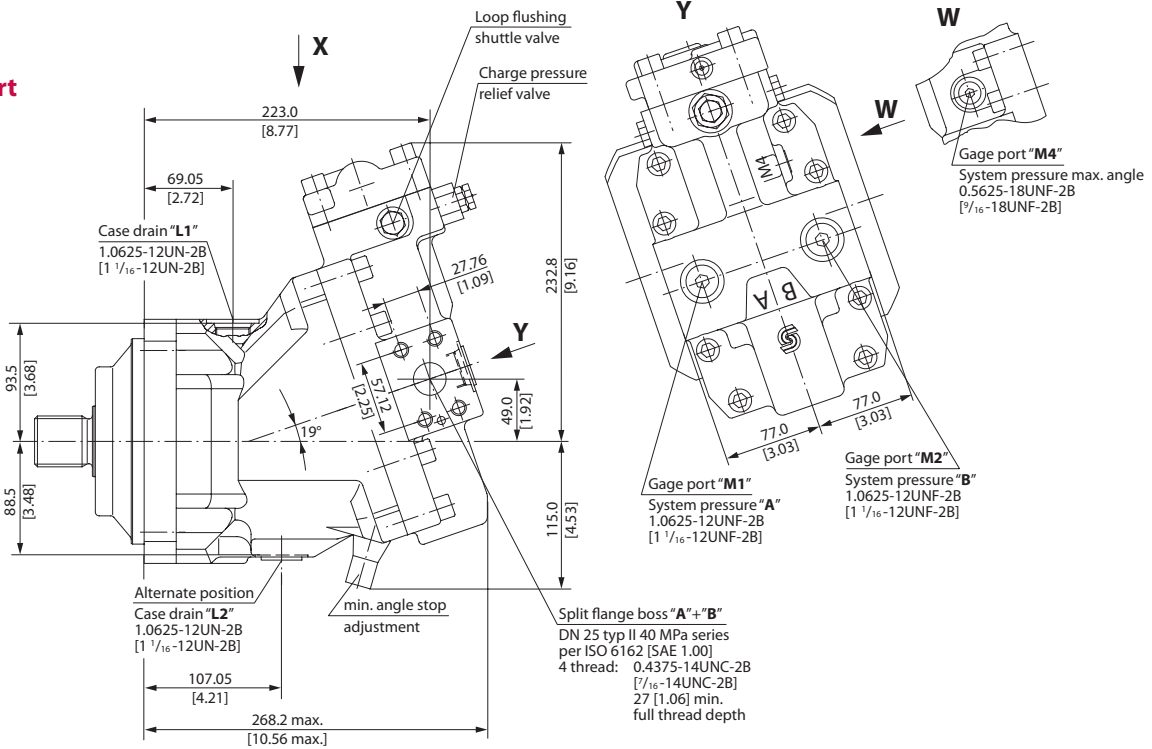

Axial Port

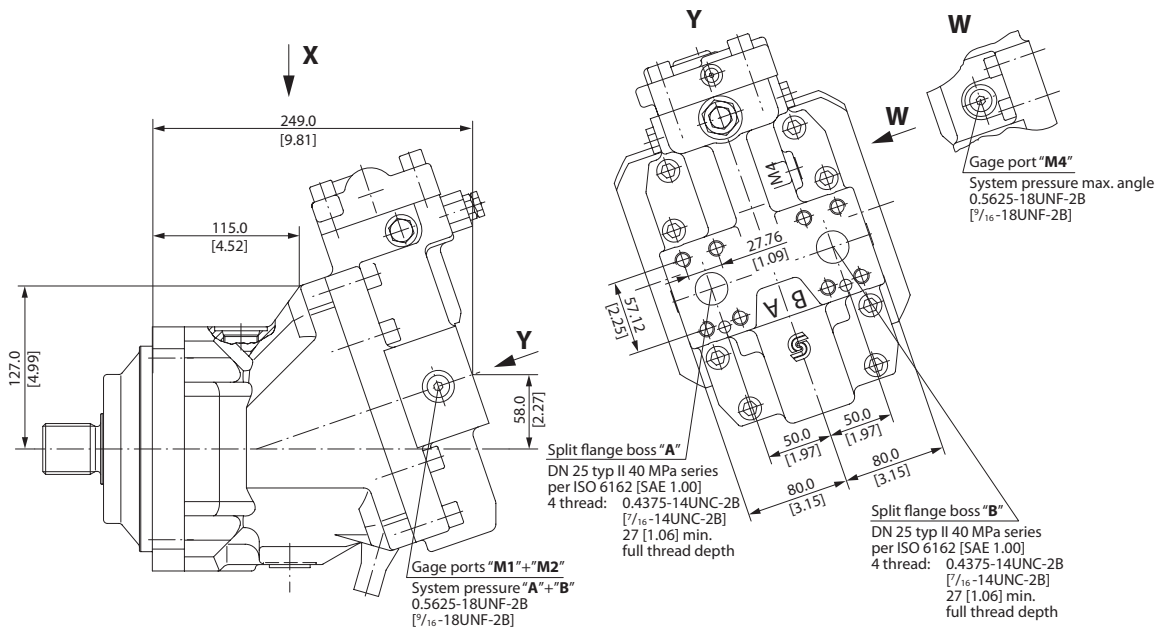

P001 801E

DIN FLANGE DESIGN
PER ISO 3019/2
(continued)

51D110 Proportional and Two-Position Control, HZB1

mm
 [in]

Side Port

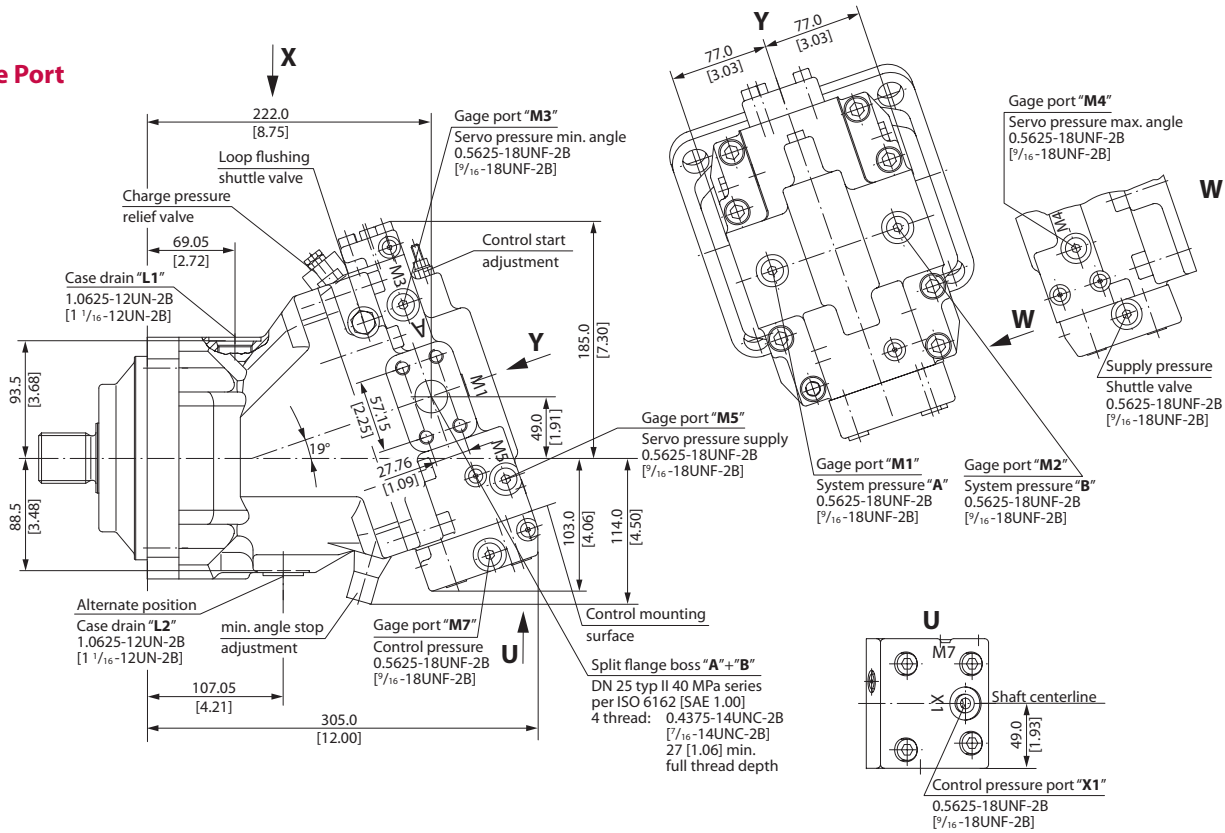

Axial Port

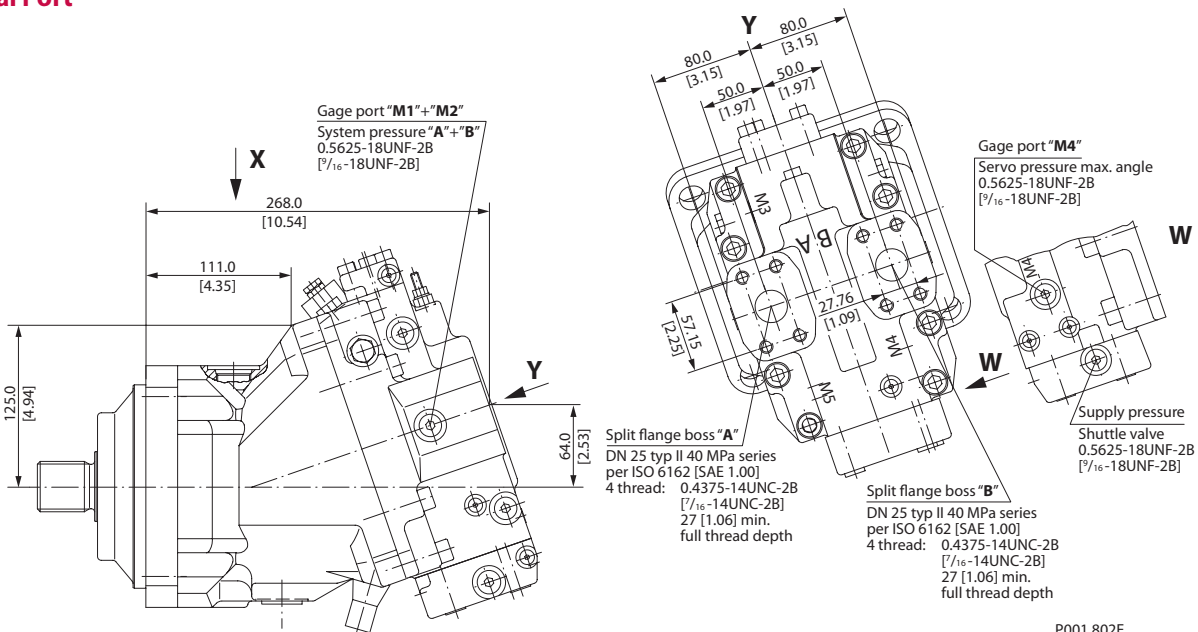

P001 802E

**DIN FLANGE DESIGN
 PER ISO 3019/2
 (continued)**

Shaft Options – 51D110-1 and 51D110

mm
 [in]

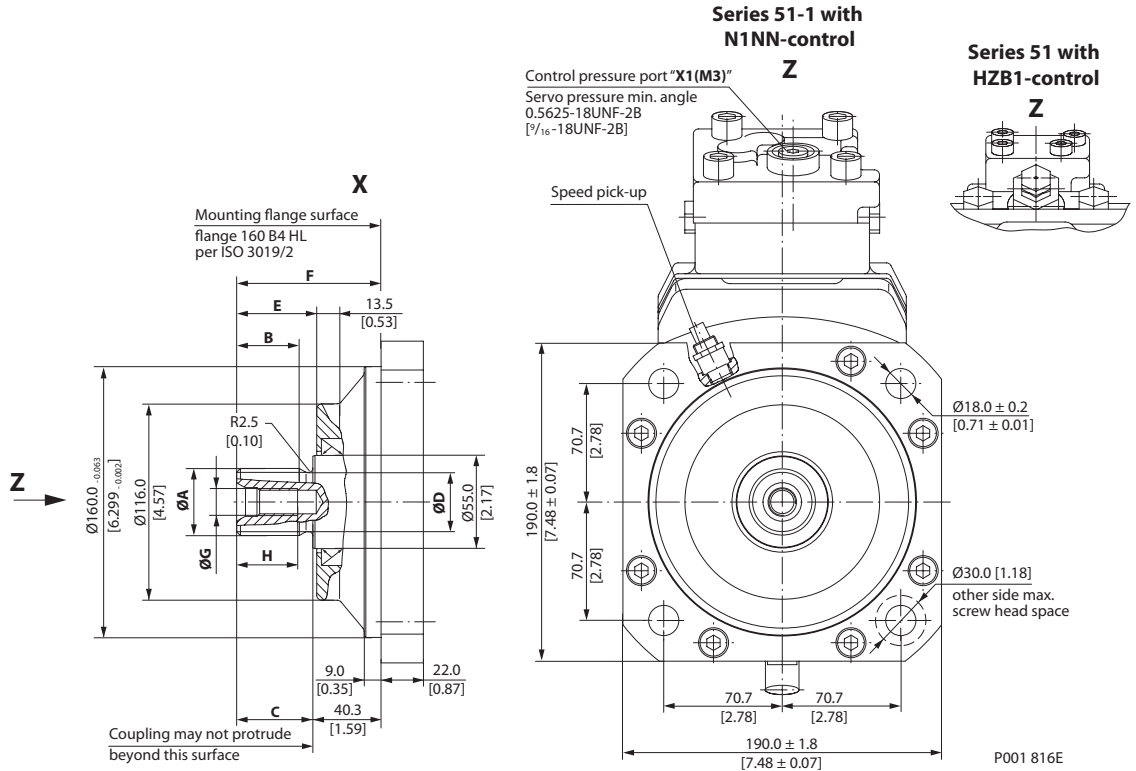

Shaft Spline Data				
Shaft option	D3		D4	
Dimension	mm	[in]	mm	[in]
Number of teeth	18		21	
Spline	W40x2x30x18x9g side fit DIN 5480		W45x2x30x21x9g side fit DIN 5480	
Pitch dia	36.000	[1.417]	42.000	[1.654]
Ø A	39.60	[1.56]	44.60	[1.76]
B	37.00	[1.46]	42.00	[1.65]
C	45.00±0.5	[1.77]	50.00±0.5	[1.97]
Ø D	35.00	[1.38]	40.00	[1.57]
E	47.30±1.1	[1.86]	52.30±1.1	[2.06]
F	85.30±0.6	[3.36]	90.30±0.6	[3.56]
Ø G	M12x1.75 allowed torque in thread max. 115 Nm [1018 lbf·in]			
H	30.00	[1.18]	30.00	[1.18]

Flow into port **A** results in **CW** rotation of output shaft.
 Flow into port **B** results in **CCW** rotation of output shaft.
 Shaft rotation is determined by viewing from shaft end.
 Ports with O-ring seal and inch threads shall be in accordance with ISO 11926/1.
 Split flange boss A and B per ISO 6162 is identical with high pressure series SAE J518 code 62 (6000 psi).
 Contact your Sauer-Danfoss representative for specific installation drawings.

CARTRIDGE FLANGE

51C110-1 Two Position Control, N1NN

mm
[in]

Side Port

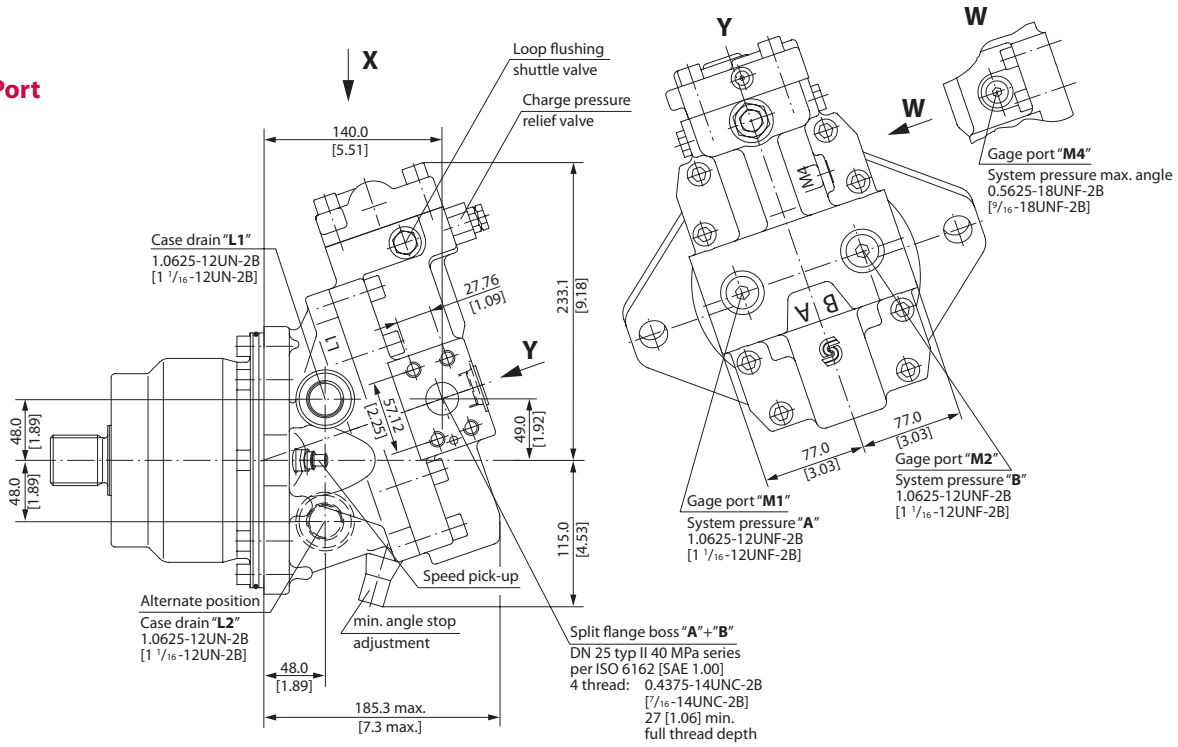

Axial Port

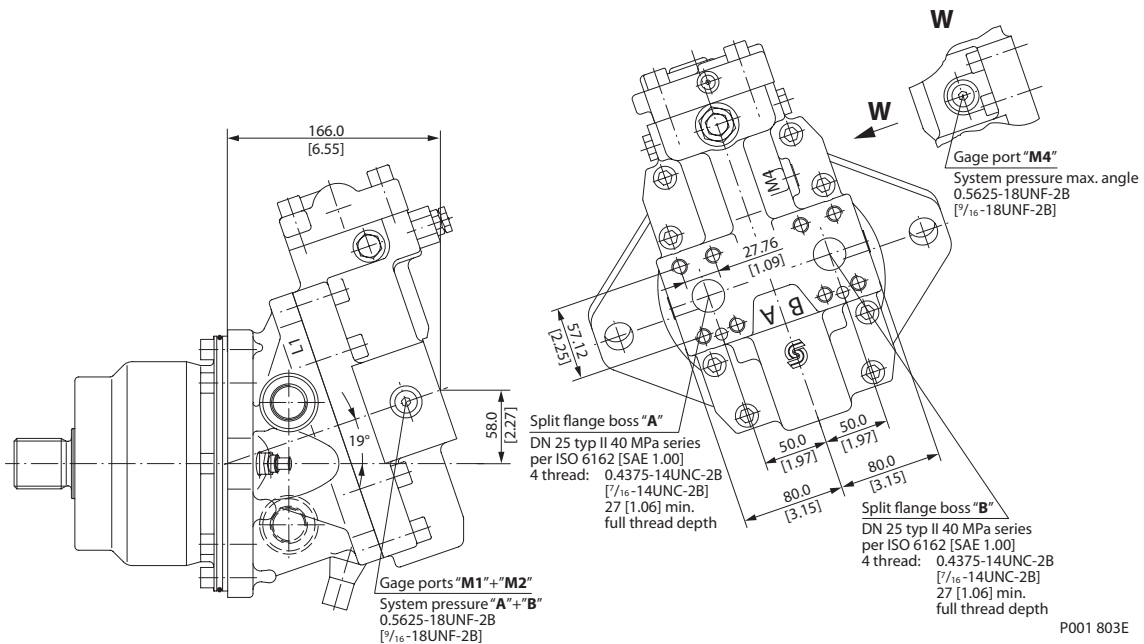

**CARTRIDGE FLANGE
 (continued)**

51C110 Proportional and Two-Position Control, HZB1

mm
 [in]

Side Port

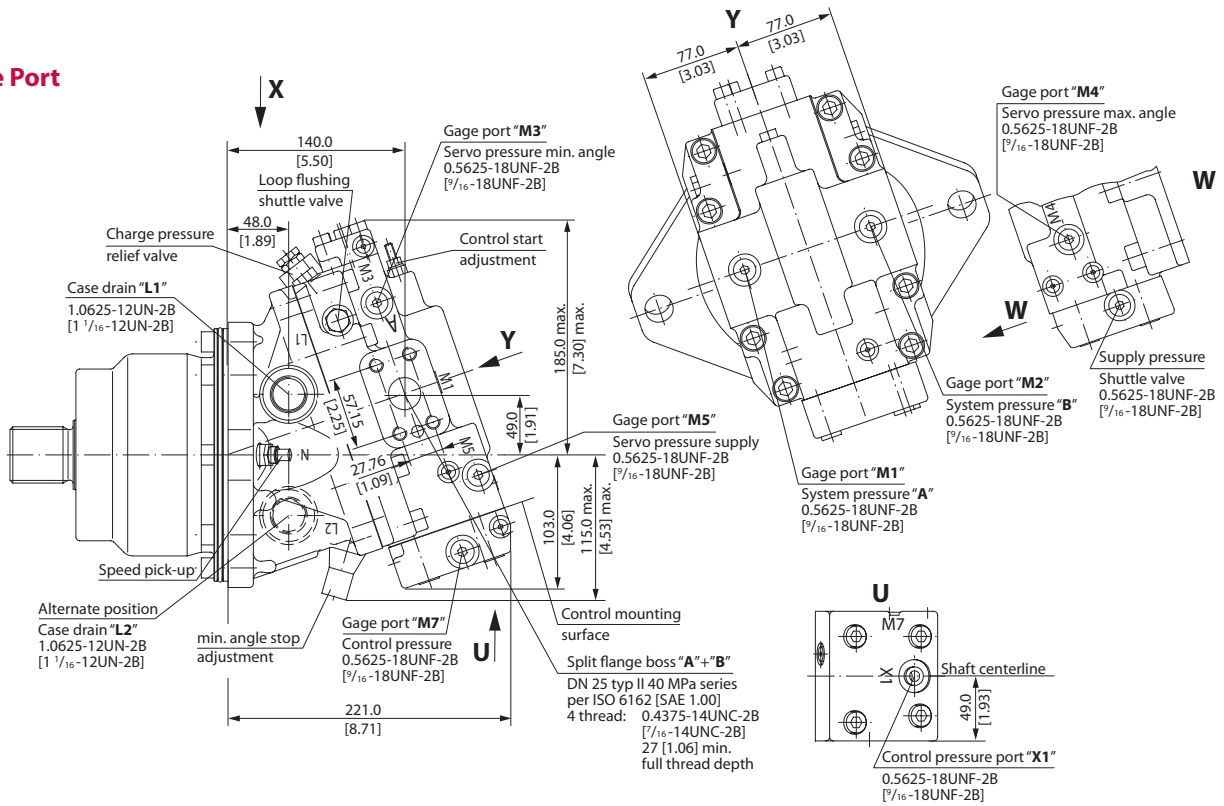

Axial Port

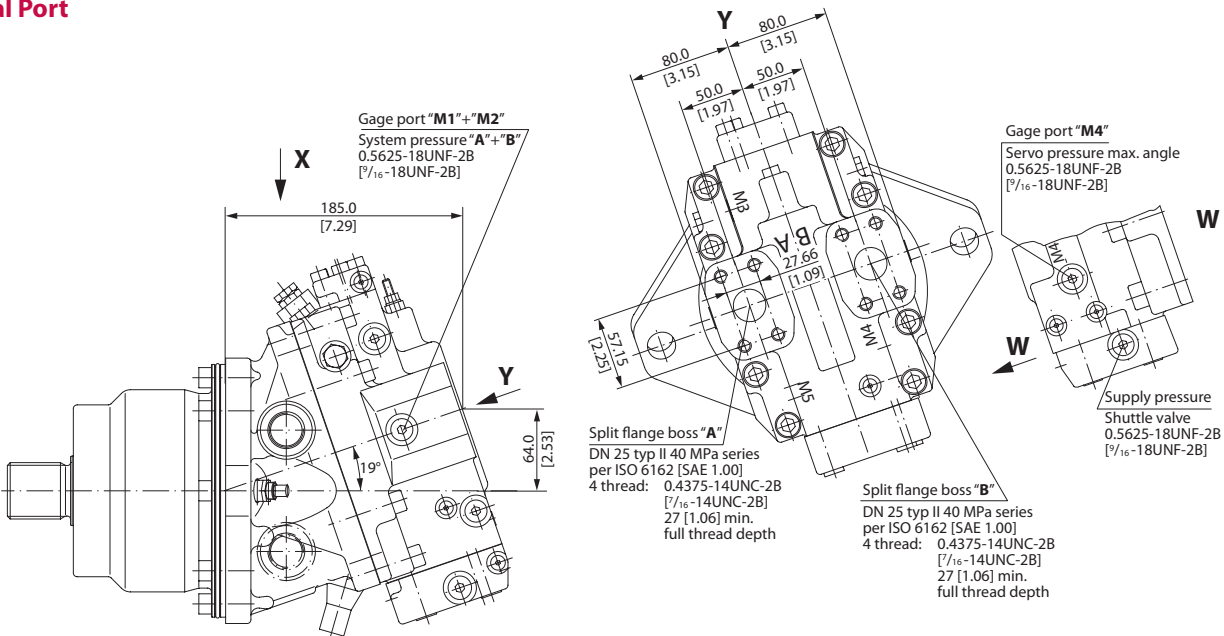

P001 804E

CARTRIDGE FLANGE
 (continued)

Shaft Options – 51C110-1 and 51C110

mm
 [in]

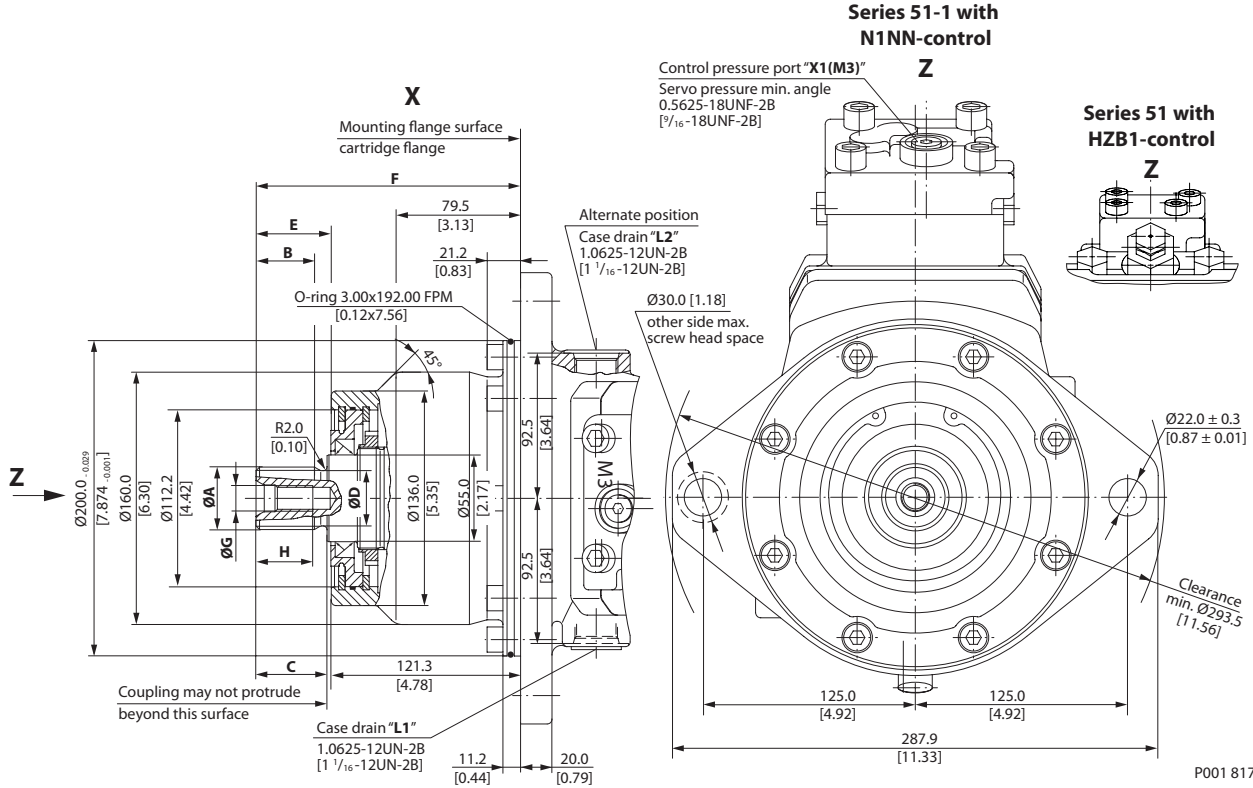

Shaft Spine Data				
Shaft option	D3		D4	
	mm	[in]	mm	[in]
Dimension				
Number of teeth	18		21	
Spline	W40x2x30x18x9g side fit DIN 5480		W45x2x30x21x9g side fit DIN 5480	
Pitch dia	36.000	[1.417]	42.000	[1.654]
Ø A	39.60	[1.56]	44.60	[1.76]
B	37.00	[1.46]	42.00	[1.65]
C	45.00±0.5	[1.77]	50.00±0.5	[1.97]
Ø D	35.00	[1.38]	40.00	[1.57]
E	47.40±1.1	[1.87]	52.40±1.4	[2.06]
F	167.70±0.6	[6.60]	172.70±0.6	[6.80]
Ø G	M12x1.75 allowed torque in thread max. 115 Nm [1018 lbf·in]			
H	30.00	[1.18]	30.00	[1.18]

Flow into port **A** results in **CW** rotation of output shaft.
 Flow into port **B** results in **CCW** rotation of output shaft.
 Shaft rotation is determined by viewing from shaft end.
 Ports with O-ring seal and inch threads shall be in accordance with ISO 11926/1.
 Split flange boss A and B per ISO 6162 is identical with high pressure series SA E J518 code 62 (6000 psi).
 Contact your Sauer-Danfoss representative for specific installation drawings.



Series 51 and 51-1 Bent Axis Variable Displacement Motors
Technical Information
Notes

**SAE FLANGE DESIGN
 PER ISO 3019/1**

51V160 Proportional and Two-Position Control, HZB1

mm
 [in]

Side Port

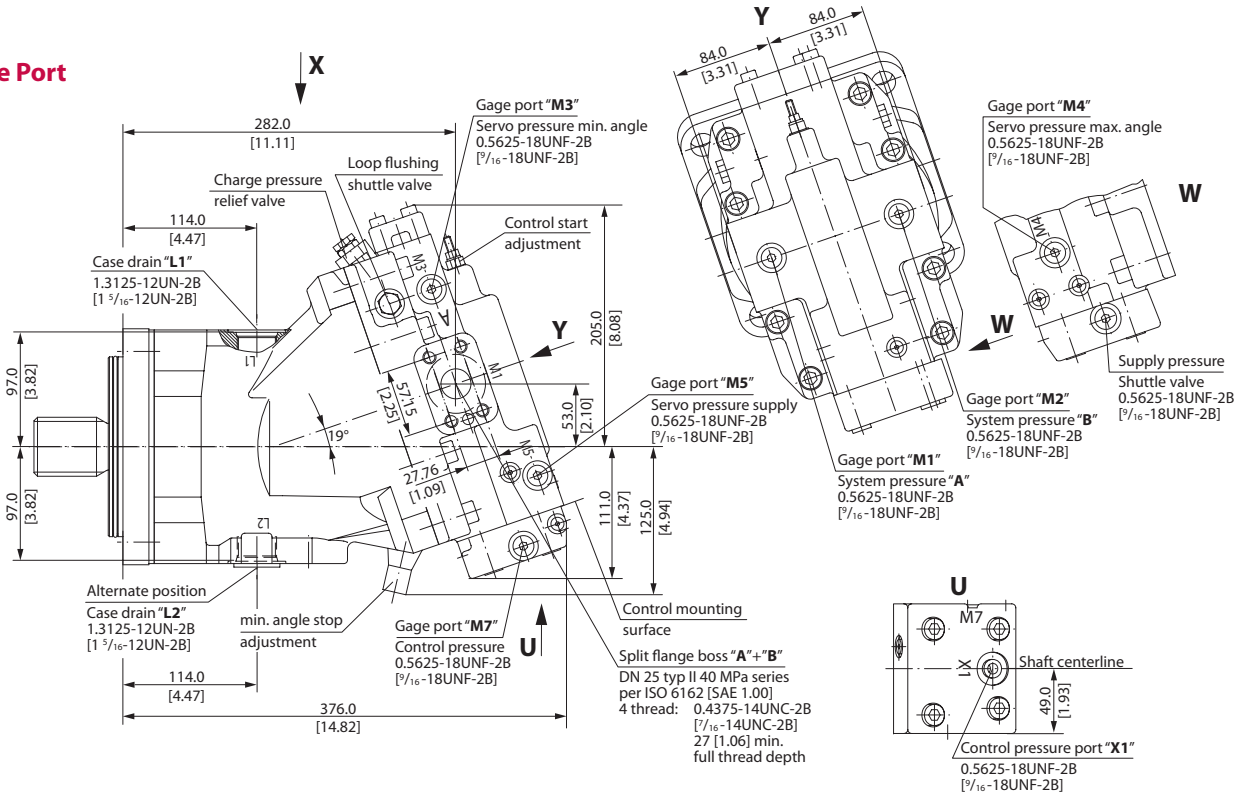

Axial Port

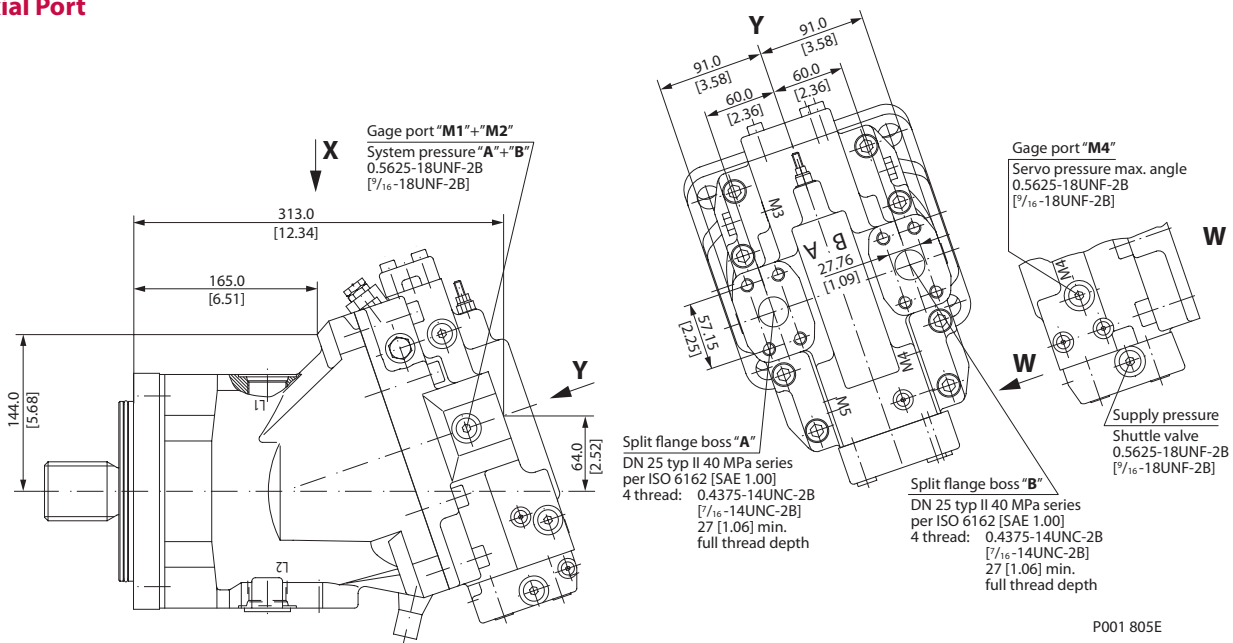

P001 805E

SAE FLANGE DESIGN
 PER ISO 3019/1
 (continued)

Shaft Options – 51V160

mm
 [in]

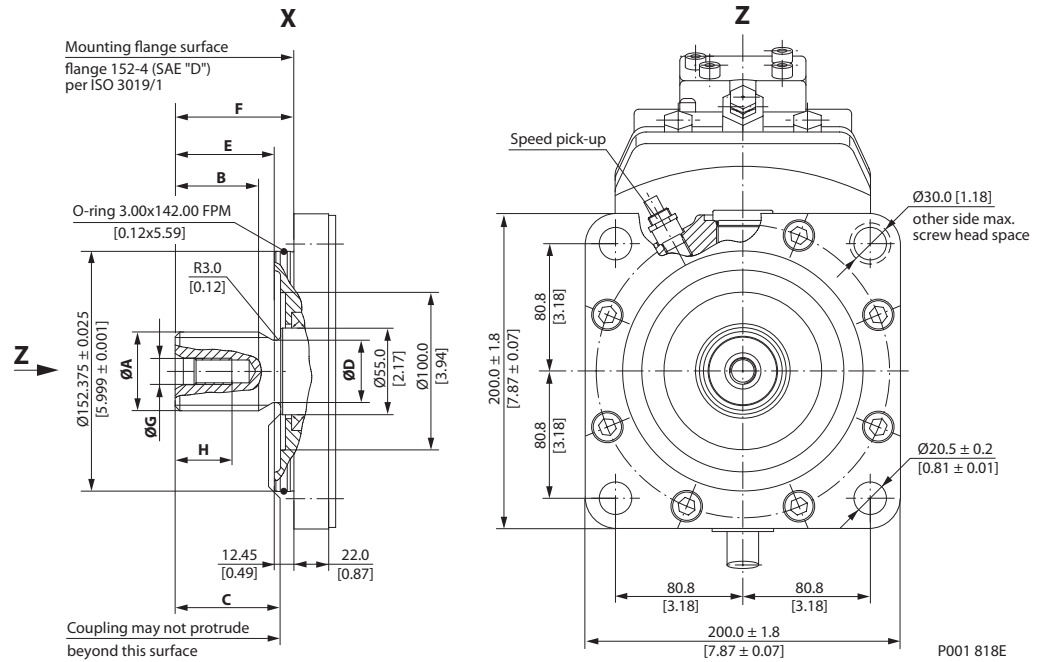

Shaft Spline Data					
Shaft option	F1		F2		C8
Dimension	mm	[in]	mm	[in]	mm [in]
Number of teeth	13		15		27
Pitch	8/16		8/16		16/32
Pressure angle	30°				
Spline	ANSI B92.1-1970 class 5 flat root side fit				
Pitch dia	41.275	[1.625]	47.625	[1.875]	42.862 [1.688]
Ø A	43.64	[1.72]	49.99	[1.97]	43.96 [1.73]
B	55.00	[2.17]	53.00	[2.09]	55.00 [2.17]
C	67.00±0.5	[2.64]	67.00±0.5	[2.64]	67.00±0.5 [2.64]
Ø D	36.00	[1.42]	42.20	[1.66]	39.60 [1.56]
E	70.00±1.1	[2.76]	70.00±1.1	[2.76]	70.00±1.1 [2.76]
F	75.40±0.7	[2.97]	75.40±0.7	[2.97]	75.40±0.7 [2.97]
Ø G	0.625-11UNC-2B [5/8-11UNC-2B] allowed torque in thread max. 200 Nm [1770 lbf·in]				
H	36.00	[1.42]	36.00	[1.42]	36.00 [1.42]

Flow into port **A** results in **CW** rotation of output shaft.
 Flow into port **B** results in **CCW** rotation of output shaft.
 Shaft rotation is determined by viewing from shaft end.
 Ports with O-ring seal and inch threads shall be in accordance with ISO 11926/1.
 Splite flange boss A and B per ISO 6162 is identical with high pressure series SAE J518 code 62 (6000 psi).
 Contact your Sauer-Danfoss representative for specific installation drawings.

**DIN FLANGE DESIGN
 PER ISO 3019/2**

51D160 Proportional and Two-Position Control, HZB1

mm
 [in]

Side Port

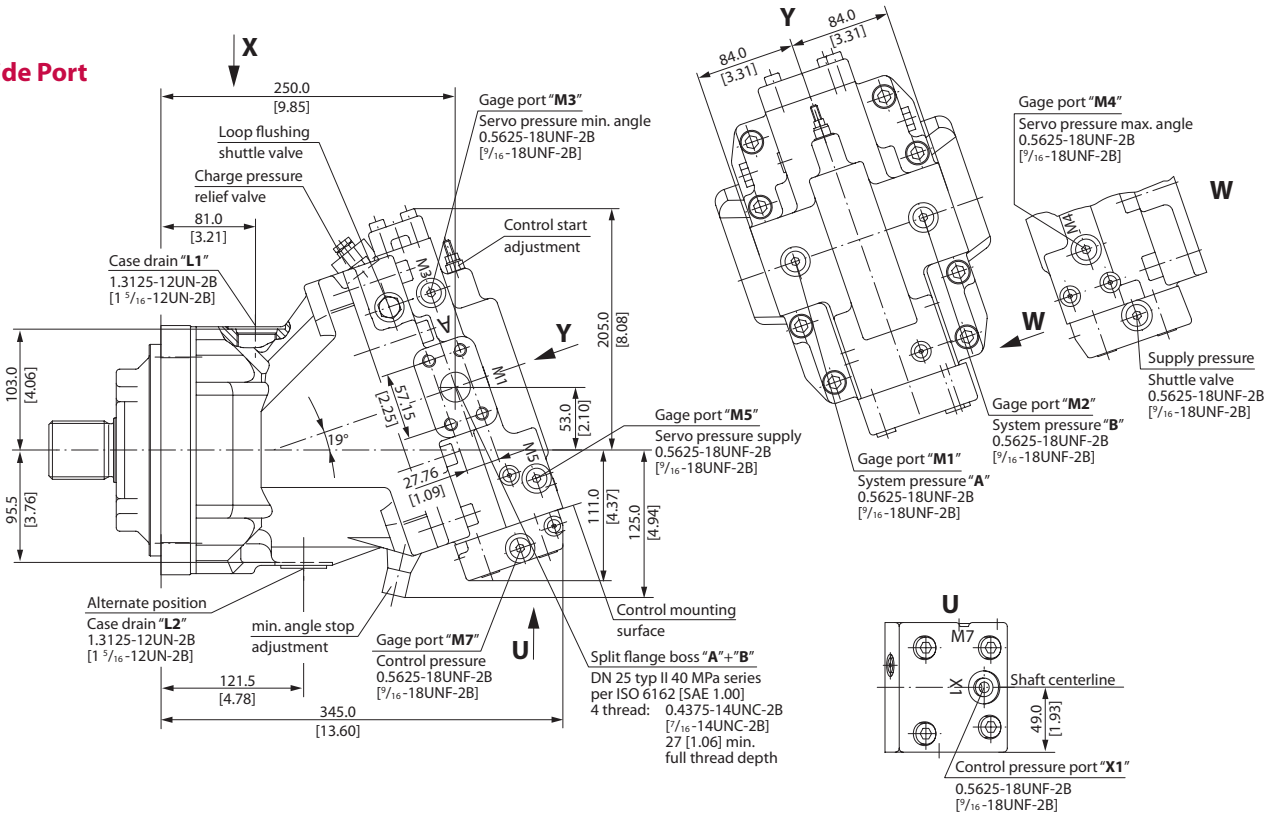

Axial Port

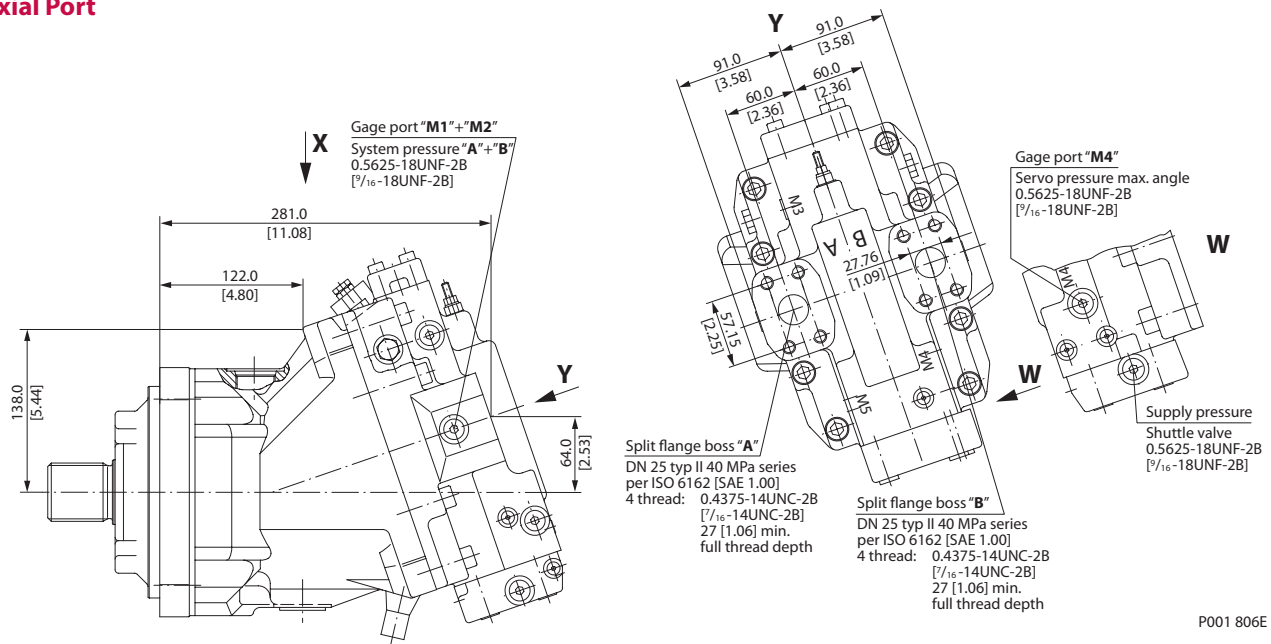

P001 806E

**DIN FLANGE DESIGN
 PER ISO 3019/2
 (continued)**

Shaft Options – 51D160

mm
 [in]

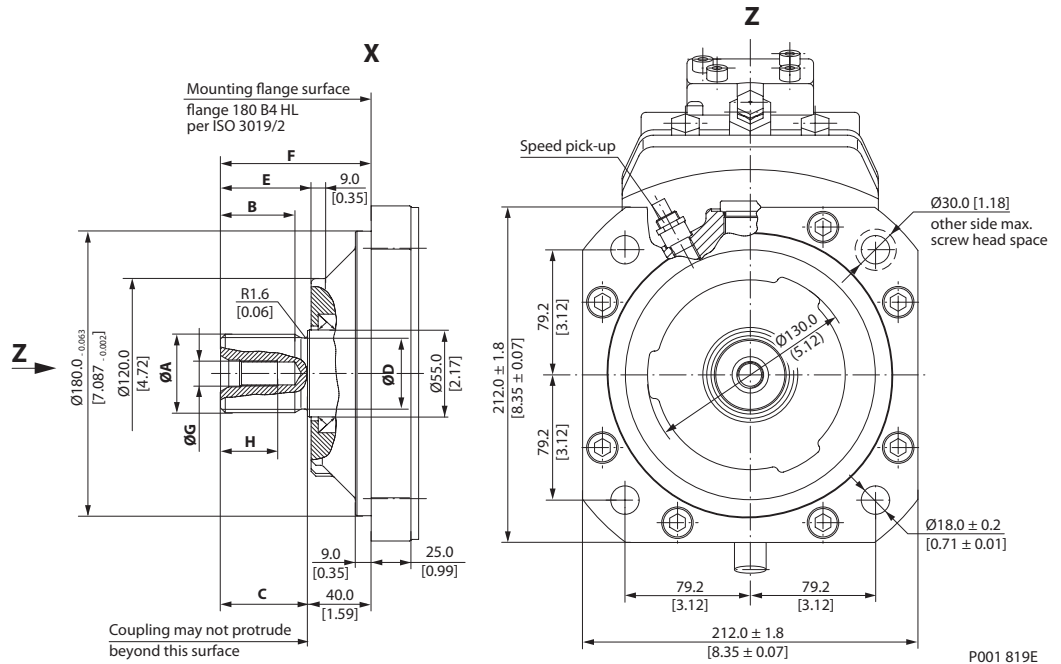

Shaft Spline Data				
Shaft option	D4		D5	
Dimension	mm	[in]	mm	[in]
Number of teeth	21		24	
Spline	W45x2x30x21x9g side fit DIN 5480		W50x2x30x24x9g side fit DIN 5480	
Pitch dia	42.000	[1.654]	48.000	[1.890]
Ø A	44.60	[1.76]	49.60	[1.95]
B	42.00	[1.65]	47.00	[1.85]
C	50.00±0.5	[1.97]	55.00±0.5	[2.17]
Ø D	40.00	[1.57]	45.00	[1.77]
E	52.30±1.1	[2.06]	57.30±1.1	[2.26]
F	90.30±0.6	[3.56]	95.30±0.6	[3.75]
Ø G	M12x1.75 allowed torque in thread max. 115 Nm [1018 lbf·in]			
H	30.00	[1.18]	30.00	[1.18]

Flow into port **A** results in **CW** rotation of output shaft.
 Flow into port **B** results in **CCW** rotation of output shaft.
 Shaft rotation is determined by viewing from shaft end.
 Ports with O-ring seal and inch threads shall be in accordance with ISO 11926/1.
 Split flange boss A and B per ISO 6162 is identical with high pressure series SAE J518 code 62 (6000 psi).
 Contact your Sauer-Danfoss representative for specific installation drawings.

CARTRIDGE FLANGE

51C160 Proportional and Two-Position Control, HZB1

mm
[in]

Side Port

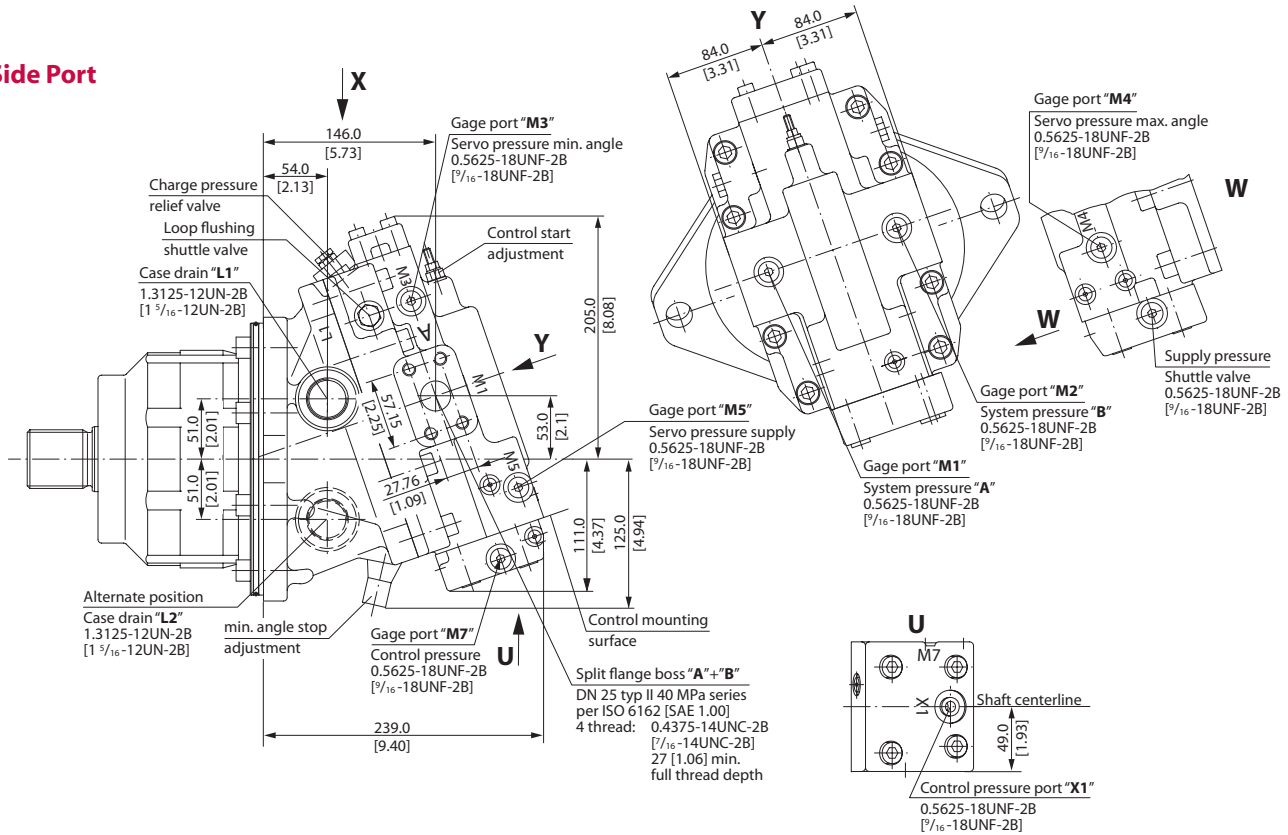

Axial Port

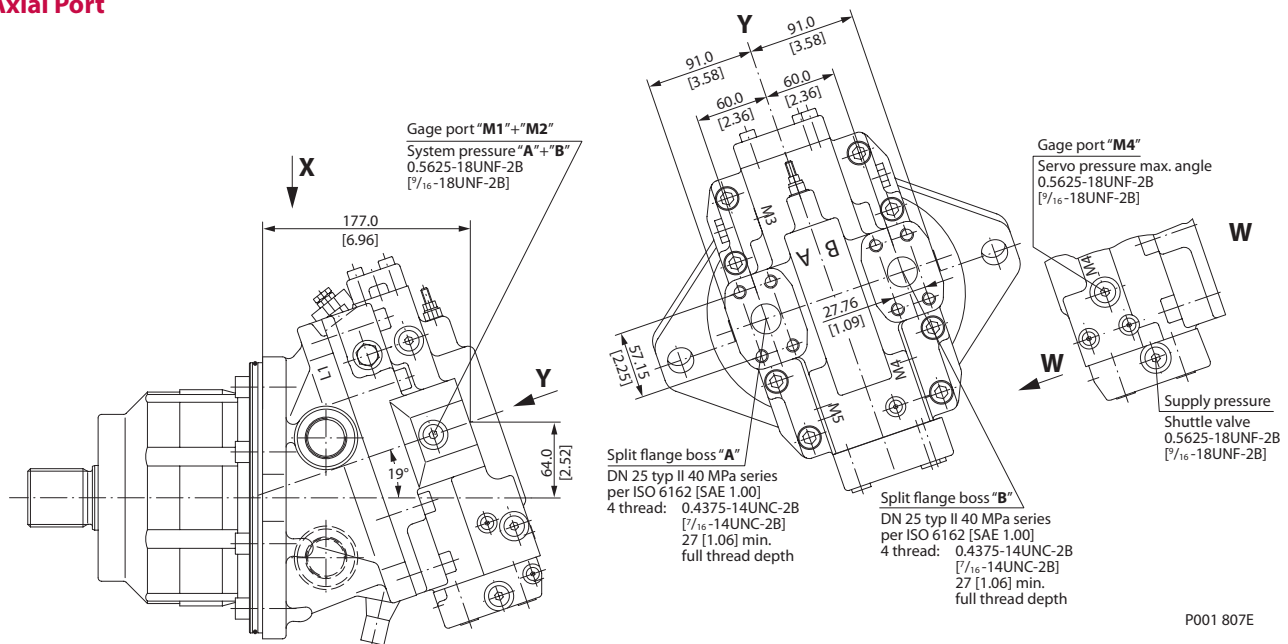

P001 807E

CARTRIDGE FLANGE
 (continued)

Shaft Options – 51C160

mm
 [in]

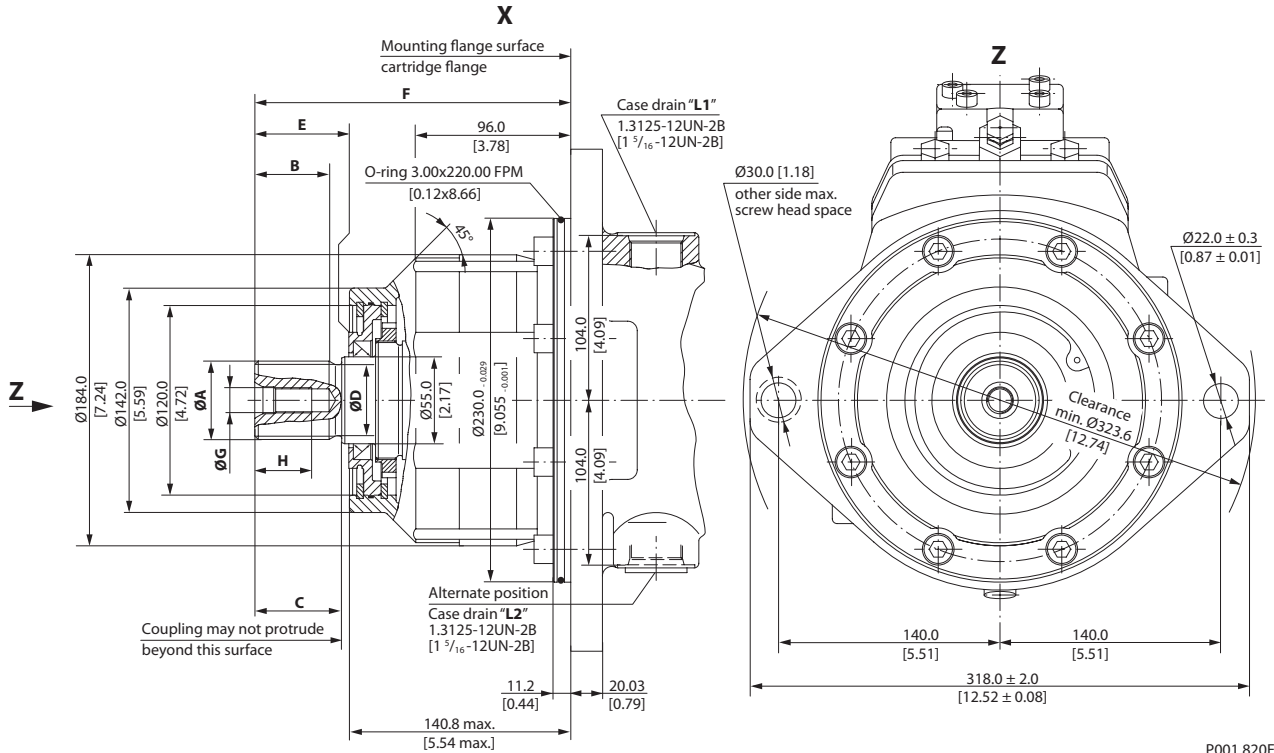

P001 820E

Shaft Spline Data				
Shaft option	D4		D5	
Dimension	mm	[in]	mm	[in]
Number of teeth	21		24	
Spline	W45x2x30x21x9g side fit DIN 5480		W50x2x30x24x9g side fit DIN 5480	
Pitch dia	42.000	[1.654]	48.000	[1.890]
Ø A	44.60	[1.76]	49.60	[1.95]
B	42.00	[1.65]	47.00	[1.85]
C	50.00±0.5	[1.97]	55.00±0.5	[2.17]
Ø D	40.00	[1.57]	45.00	[1.77]
E	54.50±1.4	[2.15]	59.50±1.4	[2.34]
F	194.90±0.6	[7.67]	199.90±0.6	[7.87]
Ø G	M12x1.75 allowed torque in thread max. 115 Nm [1018 lbf·in]			
H	30.00	[1.18]	30.00	[1.18]

Flow into port **A** results in **CW** rotation of output shaft.
 Flow into port **B** results in **CCW** rotation of output shaft.
 Shaft rotation is determined by viewing from shaft end.
 Ports with O-ring seal and inch threads shall be in accordance with ISO 11926/1.
 Split flange boss A and B per ISO 6162 is identical with high pressure series SAE J518 code 62 (6000 psi).
 Contact your Sauer-Danfoss representative for specific installation drawings.

**SAE FLANGE DESIGN
 PER ISO 3019/1**

51V250 Proportional and Two-Position Control, HZB1

mm
 [in]

Side Port

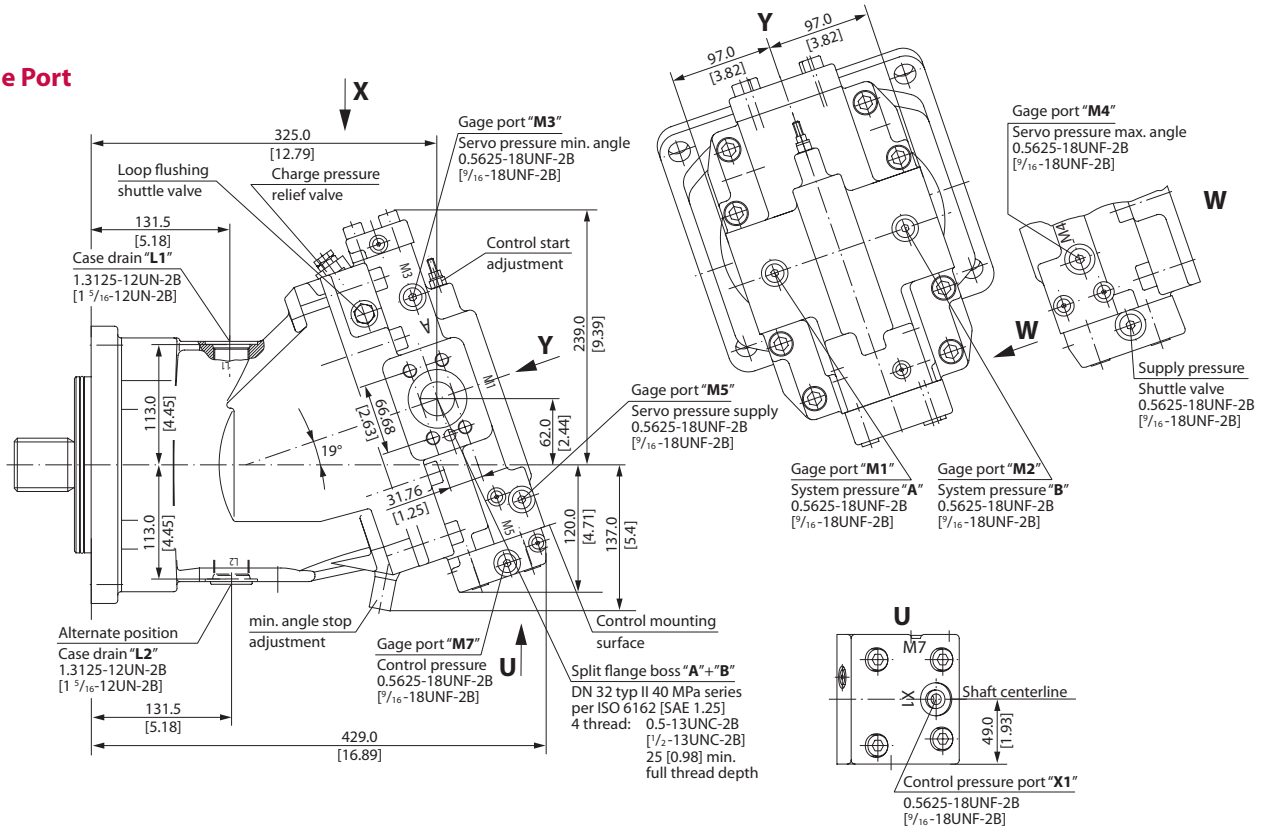

Axial Port

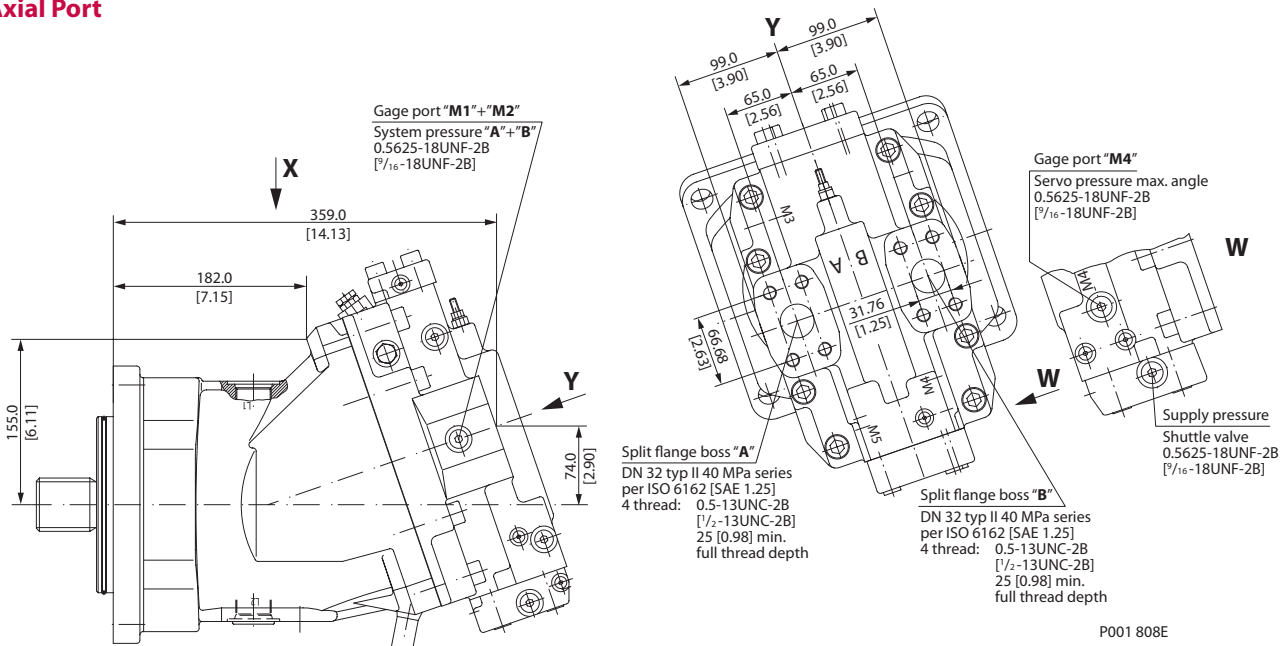

P001 808E

SAE FLANGE DESIGN
 PER ISO 3019/1
 (continued)

Shaft Options – 51V250

mm
 [in]

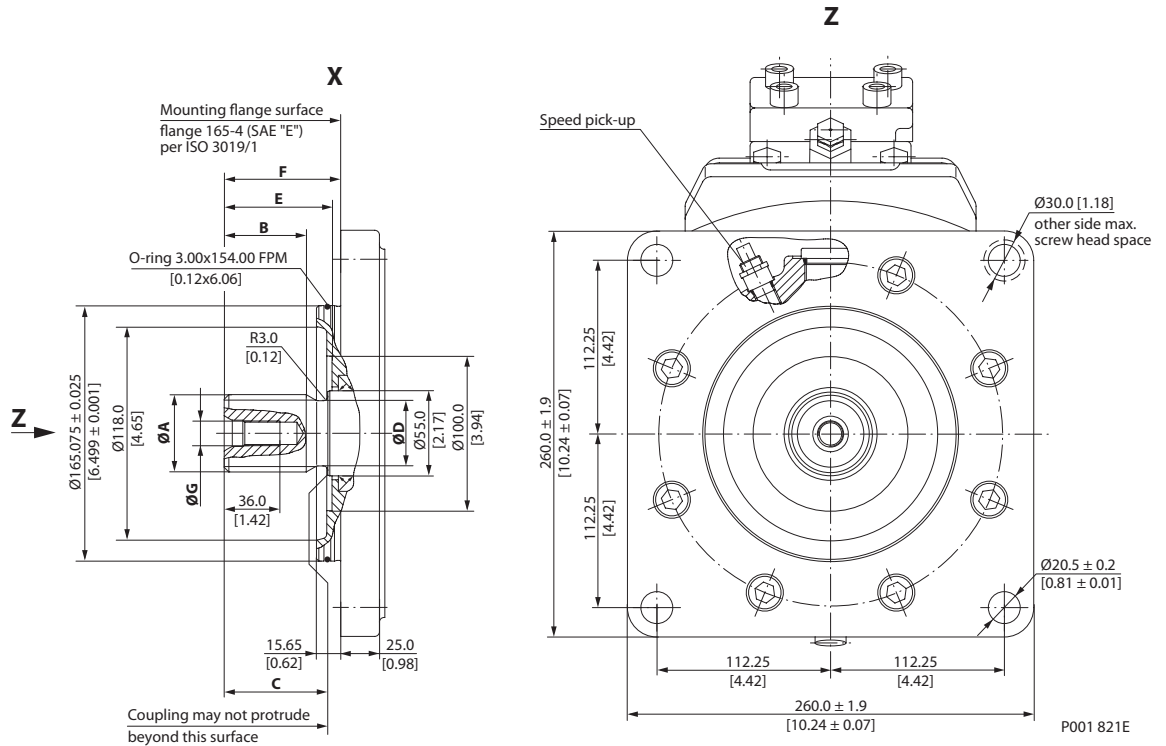

Shaft Spline Data				
Shaft option	F2		C8	
Dimension	mm	[in]	mm	[in]
Number of teeth	15		27	
Pitch	8/16		16/32	
Pressure angle	30°			
Spline	ANSI B92.1-1970 class 5 flat root side fit			
Pitch dia	47.625	[1.875]	42.862	[1.688]
Ø A	49.99	[1.97]	43.96	[1.73]
B	53.00	[2.09]	55.00	[2.17]
C	67.00±0.5	[2.64]	67.00±0.5	[2.64]
Ø D	42.20	[1.66]	39.60	[1.56]
E	70.00±1.1	[2.76]	70.00±1.1	[2.76]
F	75.40±0.7	[2.97]	75.40±0.7	[2.97]
Ø G	0.625-11UNC-2B [5/8-11UNC-2B] allowed torque in thread max. 200 Nm [1770 lbf·in]			

Flow into port **A** results in **CW** rotation of output shaft.
 Flow into port **B** results in **CCW** rotation of output shaft.
 Shaft rotation is determined by viewing from shaft end.
 Ports with O-ring seal and inch threads shall be in accordance with ISO 11926/1.
 Splite flange boss A and B per ISO 6162 is identical with high pressure series SAE J518 code 62 (6000 psi).
 Contact your Sauer-Danfoss representative for specific installation drawings.

**PRESSURE
 COMPENSATOR
 CONTROL – OPTIONS**

TA**

FOR 51-1

**FRAME SIZE
 060, 080, 110**

mm
 [in]

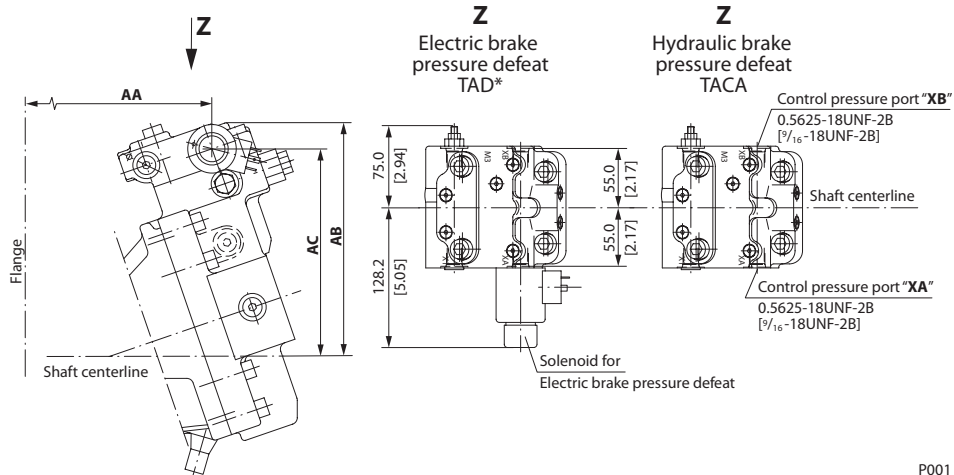

P001 838E

Control Option TA** for 51-1										
Frame size		060			080			110		
Design		V	D	C	V	D	C	V	D	C
AA	mm [in]	181.2 [7.13]	156.7 [6.17]	96.9 [3.82]	196.9 [7.75]	172.9 [6.81]	94.5 [3.72]	213.4 [8.40]	181.8 [7.16]	99.0 [3.90]
AB	mm [in]	199.3 [7.85]			209.7 [8.26]			223.5 [8.80]		
AC	mm [in]	176.4 [6.95]			186.8 [7.36]			200.6 [7.90]		

V = SAE-flange, D = DIN-flange, C = Cartridge-flange

Solenoid Connectors

**Solenoid plug face
 for DIN 46350**
 (Supplied Connector)

Mating Connector
 No.: K09129
 Id.-No.: 514117

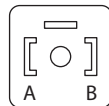

P001 752E

**AMP Junior Timer
 Two Pin Connector**
 (Supplied Connector)

Mating Connector
 No.: K19815
 Id.-No.: 508388

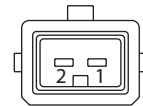

P001 751E

Shaft rotation is determined by viewing from shaft end.

Ports with O-ring seal and inch threads shall be in accordance with ISO 11926/1.

Split flange boss A and B per ISO 6162 is identical with high pressure series SAE J518 code 62 (6000 psi).

Contact your Sauer-Danfoss representative for specific installation drawings.

**PRESSURE
 COMPENSATOR
 CONTROL – OPTIONS**

TA**

FOR 51

**FRAME SIZE
 160, 250**

mm
 [in]

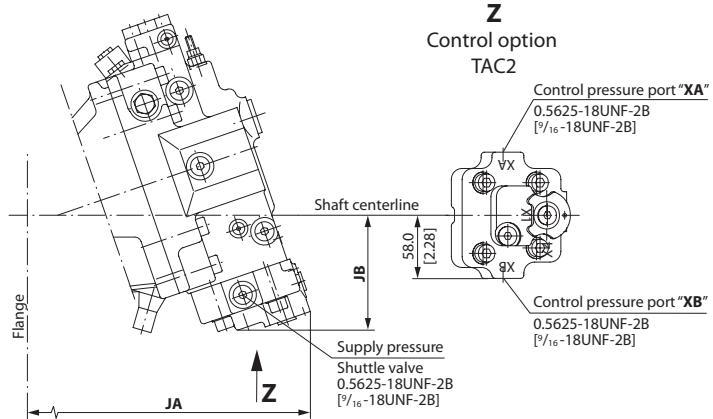

P001 839E

Control Option TA** for 51							
Frame size		160			250		
Design		V	D	C	V	D	C
JA	mm [in]	393 [15.48]	361 [14.22]	257 [10.11]	445 [17.51]	—	
JB	mm [in]	114 [4.48]			122 [4.82]	—	

V = SAE-flange, D = DIN-flange, C = Cartridge-flange
 — = not available

Shaft rotation is determined by viewing from shaft end.
 Ports with O-ring seal and inch threads shall be in accordance with ISO 11926/1.
 Split flange boss A and B per ISO 6162 is identical with high pressure series SAE J518 code 62 (6000 psi).
 Contact your Sauer-Danfoss representative for specific installation drawings.

**HYDRAULIC
 TWO-POSITION
 CONTROL – OPTIONS**

TH**

FOR 51-1

**FRAME SIZE
 060, 080, 110**

mm
 [in]

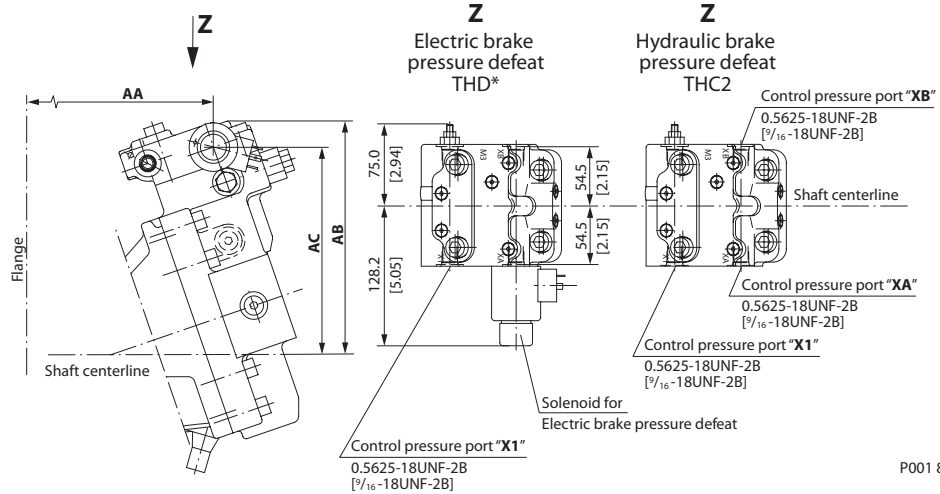

P001 840E

Control Option TH** for 51-1										
Frame size		060			080			110		
Design		V	D	C	V	D	C	V	D	C
AA	mm [in]	181.2 [7.13]	156.7 [6.17]	96.9 [3.82]	196.9 [7.75]	172.9 [6.81]	94.5 [3.72]	213.4 [8.40]	181.8 [7.16]	99.0 [3.90]
AB	mm [in]	199.3 [7.85]			209.7 [8.26]			223.5 [8.80]		
AC	mm [in]	176.4 [6.95]			186.8 [7.36]			200.6 [7.90]		

V = SAE-flange, D = DIN-flange, C = Cratridge-flange

Solenoid Connectors

**Solenoid plug face
 for DIN 46350**
 (Supplied Connector)

Mating Connector
 No.: K09129
 Id.-No.: 514117

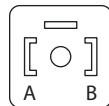

P001 752E

**AMP Junior Timer
 Two Pin Connector**
 (Supplied Connector)

Mating Connector
 No.: K19815
 Id.-No.: 508388

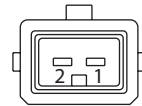

P001 751E

Shaft rotation is determined by viewing from shaft end.
 Ports with O-ring seal and inch threads shall be in accordance with ISO 11926/1.
 Splitte flange boss A and B per ISO 6162 is identical with high pressure series SAE J518 code 62 (6000 psi).
 Contact your Sauer-Danfoss representative for specific installation drawings.

**HYDRAULIC
 TWO-POSITION
 CONTROL – OPTIONS**

TH**

FOR 51

**FRAME SIZE
 160, 250**

mm
 [in]

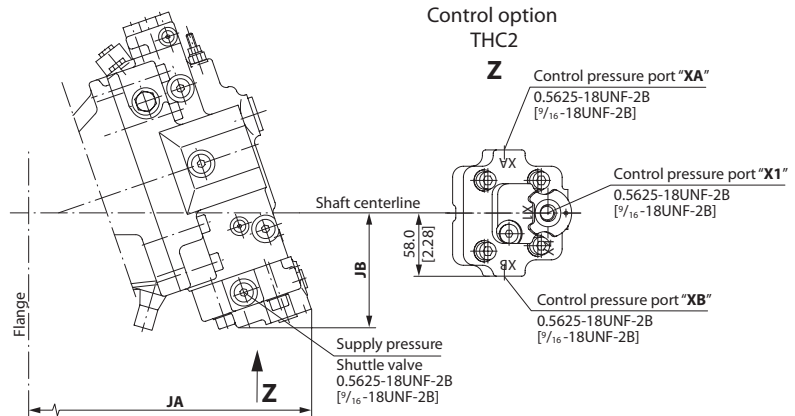

P001 841E

Control Option TH** for 51							
Frame size		160			250		
Design		V	D	C	V	D	C
JA	mm [in]	393 [15.48]	361 [14.22]	257 [10.11]	445 [17.51]	—	
JB	mm [in]	114 [4.48]			122 [4.82]	—	

V = SAE-flange, D = DIN-flange, C = Cartridge-flange
 — = not available

Shaft rotation is determined by viewing from shaft end.
 Ports with O-ring seal and inch threads shall be in accordance with ISO 11926/1.
 Split flange boss A and B per ISO 6162 is identical with high pressure series SAE J518 code 62 (6000 psi).
 Contact your Sauer-Danfoss representative for specific installation drawings.

**ELECTROHYDRAULIC
 TWO-POSITION
 CONTROL – OPTIONS**

**E1B1, E2B1, E7B1,
 F1B1, F2B1**

FOR 51-1

**FRAME SIZE
 060, 080, 110**

mm
 [in]

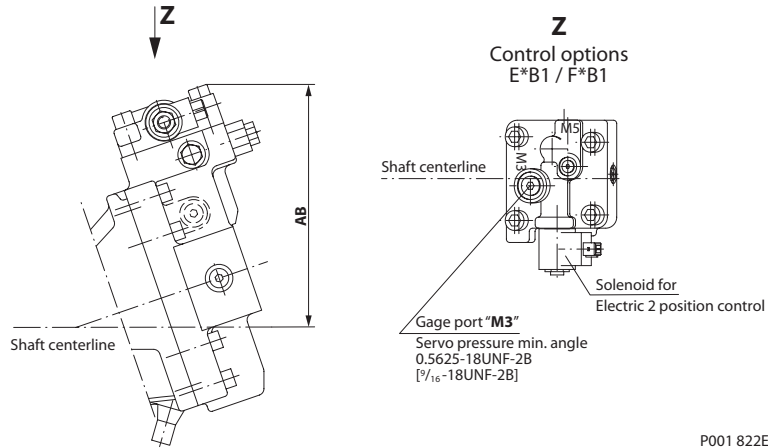

P001 822E

Control Options E1B1, E2B1, E7B1, F1B1, F2B1 for 51-1										
Frame size		060			080			110		
Design		V	D	C	V	D	C	V	D	C
AB	mm [in]	208.5 [8.21]			218.9 [8.62]			232.7 [9.16]		

V = SAE-flange, D = DIN-flange, C = Cratridge-flange

Solenoid Connectors

**Solenoid plug face
 for DIN 46350**
 (Supplied Connector)

Mating Connector
 No.: K09129
 Id.-No.: 514117



P001 752E

**AMP Junior Timer
 Two Pin Connector**
 (Supplied Connector)

Mating Connector
 No.: K19815
 Id.-No.: 508388

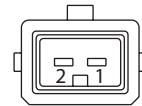

P001 751E

Shaft rotation is determined by viewing from shaft end.

Ports with O-ring seal and inch threads shall be in accordance with ISO 11926/1.

Splitte flange boss A and B per ISO 6162 is identical with high pressure series SAE J518 code 62 (6000 psi).

Contact your Sauer-Danfoss representative for specific installation drawings.

**ELECTROHYDRAULIC
 TWO-POSITION
 CONTROL – OPTIONS**

E1A5, E2A5, F1A5, F2A5

FOR 51

**FRAME SIZE
 160, 250**

mm
 [in]

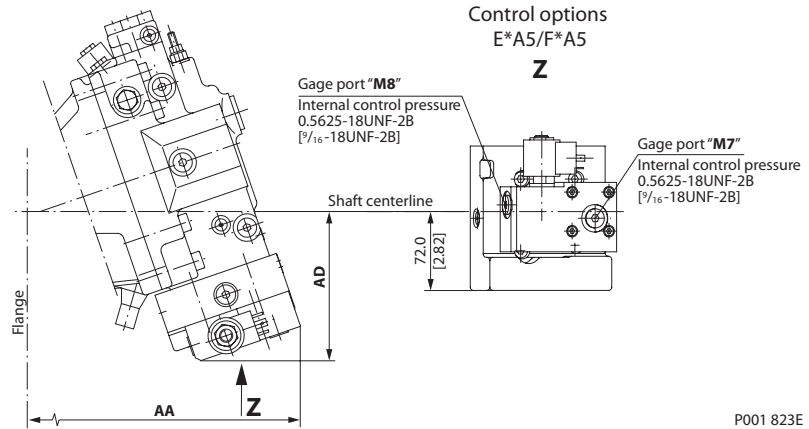

P001 823E

Control Options E1A5, E2A5, F1A5, F2A5 for 51							
Frame size		160			250		
Design		V	D	C	V	D	C
AA	mm [in]	401 [15.79]	369 [14.53]	265 [10.42]	453 [17.82]	—	
AD	mm [in]	145 [5.72]			154 [6.06]	—	

V = SAE-flange, D = DIN-flange, C = Cartridge-flange
 — = not available

Solenoid Connector

**Solenoid plug face
 for DIN 46350**
 (Supplied Connector)

Mating Connector
 No.: K09129
 Id.-No.: 514117

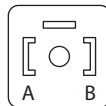

P001 752E

Shaft rotation is determined by viewing from shaft end.
 Ports with O-ring seal and inch threads shall be in accordance with ISO 11926/1.
 Split flange boss A and B per ISO 6162 is identical with high pressure series SAE J518 code 62 (6000 psi).
 Contact your Sauer-Danfoss representative for specific installation drawings.

**ELECTROHYDRAULIC
 TWO-POSITION
 CONTROL – OPTIONS**

T1, T2**, T7****

FOR 51-1

**FRAME SIZE
 060, 080, 110**

mm
 [in]

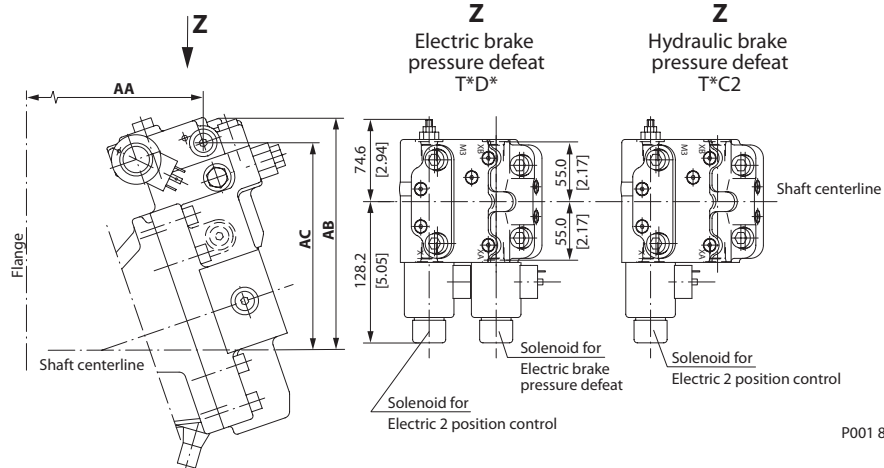

P001 824E

Control Options T1**, T2**, T7** for 51-1										
Frame size		060			080			110		
Design		V	D	C	V	D	C	V	D	C
AA	mm [in]	181.2 [7.13]	156.7 [6.17]	96.9 [3.82]	196.9 [7.75]	172.9 [6.81]	94.5 [3.72]	213.4 [8.40]	181.8 [7.16]	99.0 [3.90]
AB	mm [in]	199.3 [7.85]			209.7 [8.26]			223.5 [8.80]		
AC	mm [in]	176.4 [6.95]			186.8 [7.36]			200.6 [7.90]		

V = SAE-flange, D = DIN-flange, C = Cratridge-flange

Solenoid Connectors

**Solenoid plug face
 for DIN 46350**
 (Supplied Connector)

Mating Connector
 No.: K09129
 Id.-No.: 514117

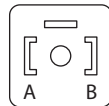

P001 752E

**AMP Junior Timer
 Two Pin Connector**
 (Supplied Connector)

Mating Connector
 No.: K19815
 Id.-No.: 508388

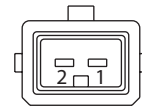

P001 751E

Shaft rotation is determined by viewing from shaft end.
 Ports with O-ring seal and inch threads shall be in accordance with ISO 11926/1.
 Splitte flange boss A and B per ISO 6162 is identical with high pressure series SAE J518 code 62 (6000 psi).
 Contact your Sauer-Danfoss representative for specific installation drawings.

**ELECTROHYDRAULIC
 TWO-POSITION
 CONTROL – OPTIONS**

T1C2, T2C2

FOR 51

**FRAME SIZE
 160, 250**

mm
 [in]

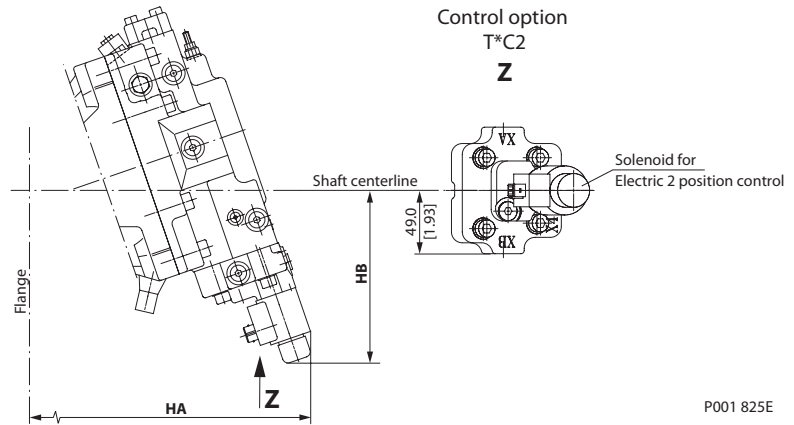

P001 825E

Control Options T1C2, T2C2 for 51						
Frame size		160			250	
Design		V	D	C	V	C
HA	mm [in]	409 [16.10]	377 [14.84]	272 [10.73]	461 [18.13]	—
HB	mm [in]	178 [7.00]			186 [7.33]	—

V = SAE-flange, D = DIN-flange, C = Cartridge-flange
 — = not available

Solenoid Connector

**Solenoid plug face
 for DIN 46350**
 (Supplied Connector)

Mating Connector
 No.: K09129
 Id.-No.: 514117

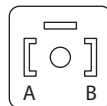

P001 752E

Shaft rotation is determined by viewing from shaft end.
 Ports with O-ring seal and inch threads shall be in accordance with ISO 11926/1.
 Splitte flange boss A and B per ISO 6162 is identical with high pressure series SAE J518 code 62 (6000 psi).
 Contact your Sauer-Danfoss representative for specific installation drawings.

**ELECTROHYDRAULIC
 PROPORTIONAL
 CONTROL – OPTIONS**

EPA1, EQA1

FOR 51

**FRAME SIZE
 060, 080, 110, 160, 250**

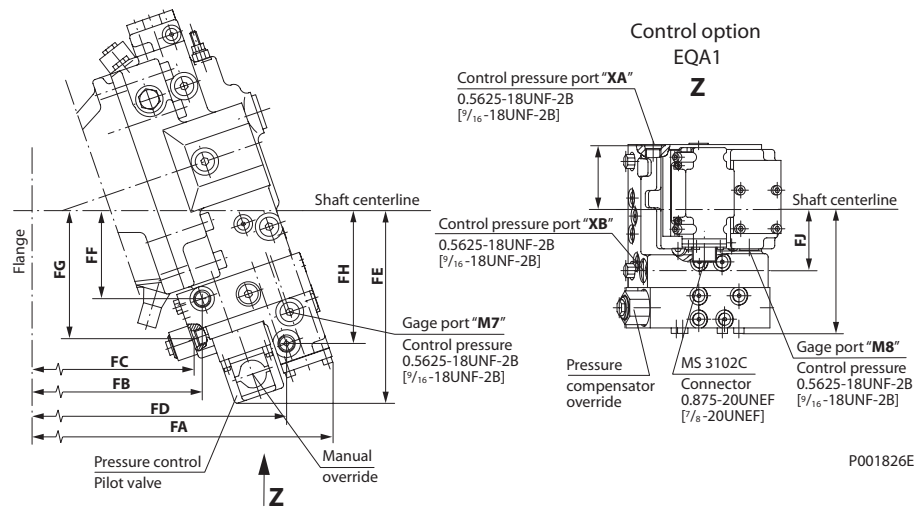

mm
[in]

Control Options EPA1, EQA1 for 51																
Frame size	060			080			110			160			250			
Design	V	D	C	V	D	C	V	D	C	V	D	C	V	D	C	
FA	mm [12.89]	327 [12.89]	303 [11.93]	243 [9.57]	351 [13.81]	327 [12.87]	249 [9.78]	369 [14.54]	337 [13.28]	255 [10.04]	409 [16.11]	377 [14.85]	273 [10.73]	461 [18.13]	—	
FB	mm [8.26]	210 [8.26]	185 [7.29]	125 [4.94]	233 [9.18]	209 [8.23]	131 [5.15]	252 [9.90]	220 [8.65]	137 [5.40]	283 [11.14]	251 [9.88]	146 [5.76]	334 [13.17]	—	
FC	mm [8.00]	203 [8.00]	179 [7.04]	119 [4.69]	226 [8.88]	202 [7.94]	123 [4.85]	244 [9.61]	212 [8.35]	130 [5.11]	276 [10.85]	244 [9.59]	139 [5.48]	327 [12.88]	—	
FD	mm [11.25]	286 [11.25]	261 [10.29]	202 [7.93]	309 [12.17]	285 [11.32]	207 [8.14]	328 [12.90]	296 [11.64]	213 [8.40]	367 [14.47]	335 [13.21]	231 [9.09]	419 [16.50]	—	
FE	mm [6.62]	168 [6.62]			174 [6.85]			176 [6.91]			183 [7.22]			192 [7.56]		
FF	mm [2.91]	74 [2.91]			80 [3.15]			81 [3.20]			92 [3.63]			101 [3.97]		
FG	mm [4.33]	110 [4.33]			116 [4.58]			118 [4.64]			129 [5.06]			137 [5.41]		
FH	mm [4.47]	114 [4.47]			120 [4.74]			122 [4.80]			130 [5.11]			138 [5.45]		
FJ	mm [2.20]	56 [2.20]			56 [2.20]			56 [2.20]			57 [2.22]			57 [2.22]		

V = SAE-flange, D = DIN-flange, C = Cartridge-flange
 — = not available

Connectors

**MS Connector
 MS3102C-14S-2P**
 (Supplied Connector)

Mating Connector
 No.: K08106
 Id.-No.: 615062



P001 753E

**Packard Weather-Pack
 4 pin**
 (Supplied Connector)

Mating Connector
 No.: K03384
 Id.-No.: 712208

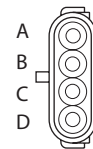

P001 759E

Shaft rotation is determined by viewing from shaft end.
 Ports with O-ring seal and inch threads shall be in accordance with ISO 11926/1.
 Split flange boss A and B per ISO 6162 is identical with high pressure series SAE J518 code 62 (6000 psi).
 Contact your Sauer-Danfoss representative for specific installation drawings.

**ELECTROHYDRAULIC
 PROPORTIONAL
 CONTROL – OPTIONS**

mm
 [in]

L1B1, L2B1, L7B1

FOR 51

**FRAME SIZE
 060, 080, 110, 160, 250**

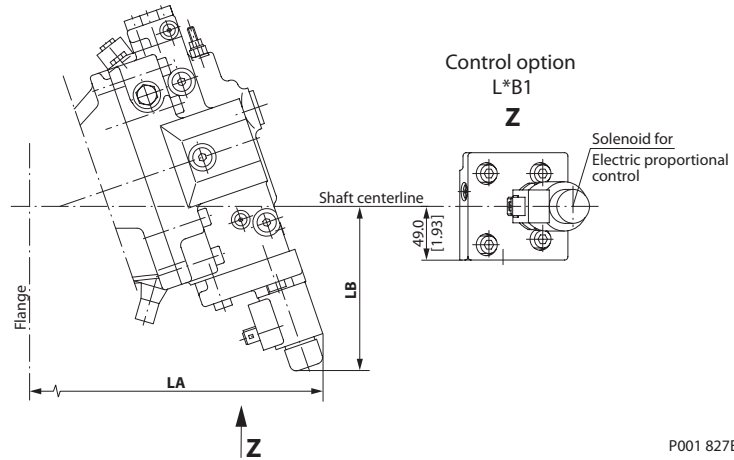

P001 827E

Control Options L1B1, L2B1, L7B1 for 51																
Frame size		060			080			110			160			250		
Design		V	D	C	V	D	C	V	D	C	V	D	C	V	D	C
LA	mm	321	296	236	344	320	242	363	331	248	402	370	266	454	—	
	[in]	[12.63]	[11.66]	[9.31]	[13.55]	[12.60]	[9.52]	[14.28]	[13.02]	[9.77]	[15.84]	[14.58]	[10.47]	[17.87]	—	
LB	mm	144			150			151			159			168		
	[in]	[5.66]			[5.90]			[5.96]			[6.27]			[6.61]		

V = SAE-flange, D = DIN-flange, C = Cartridge-flange
 — = not available

Solenoid Connectors

**Solenoid plug face
 for DIN 46350**
 (Supplied Connector)

Mating Connector
 No.: K09129
 Id.-No.: 514117

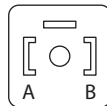

P001 752E

**AMP Junior Timer
 Two Pin Connector**
 (Supplied Connector)

Mating Connector
 No.: K19815
 Id.-No.: 508388

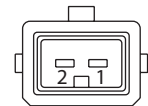

P001 751E

Shaft rotation is determined by viewing from shaft end.
 Ports with O-ring seal and inch threads shall be in accordance with ISO 11926/1.
 Split flange boss A and B per ISO 6162 is identical with high pressure series SAE J518 code 62 (6000 psi).
 Contact your Sauer-Danfoss representative for specific installation drawings.

**ELECTROHYDRAULIC
 PROPORTIONAL
 CONTROL – OPTIONS**

D7M1, D8M1

FOR 51

**FRAME SIZE
 060, 080, 110**

mm
 [in]

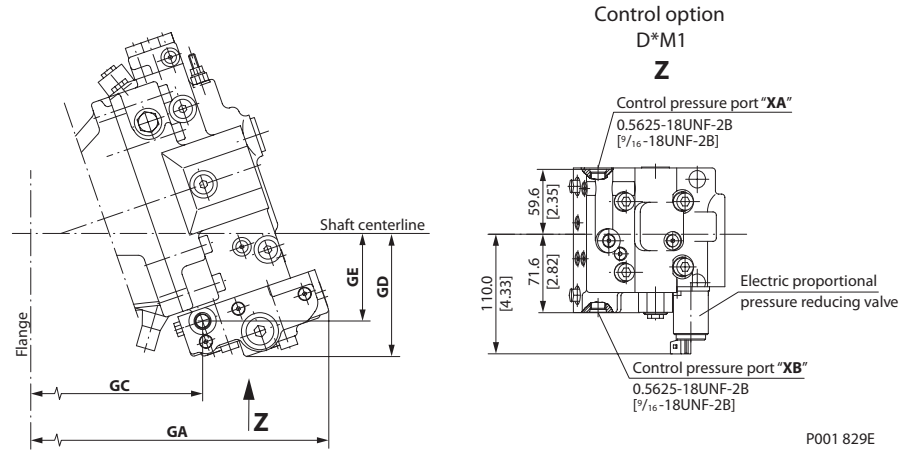

P001 829E

Control Options D7M1, D8M1 for 51										
Frame size		060			080			110		
Design		V	D	C	V	D	C	V	D	C
GA	mm	325	301	241	349	325	246	367	335	253
	[in]	[12.81]	[11.84]	[9.49]	[13.73]	[12.78]	[9.70]	[14.64]	[13.20]	[9.95]
GC	mm	210	185	125	233	209	131	252	220	137
	[in]	[8.26]	[7.29]	[4.94]	[9.18]	[8.23]	[5.15]	[9.91]	[8.65]	[5.40]
GD	mm	106			112			114		
	[in]	[4.19]			[4.42]			[4.48]		
GE	mm	74			80			81		
	[in]	[2.91]			[3.15]			[3.20]		

V = SAE-flange, D = DIN-flange, C = Cratridge-flange

Solenoid Connector

**AMP Junior Timer
 Two Pin Connector**
 (Supplied Connector)

Mating Connector
 No.: K19815
 Id.-No.: 508388

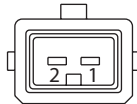

P001 751E

Shaft rotation is determined by viewing from shaft end.
 Ports with O-ring seal and inch threads shall be in accordance with ISO 11926/1.
 Splitte flange boss A and B per ISO 6162 is identical with high pressure series SAE J518 code 62 (6000 psi).
 Contact your Sauer-Danfoss representative for specific installation drawings.

**ELECTROHYDRAULIC
 PROPORTIONAL
 CONTROL – OPTIONS**

D7M1, D8M1

FOR 51

**FRAME SIZE
 160, 250**

mm
 [in]

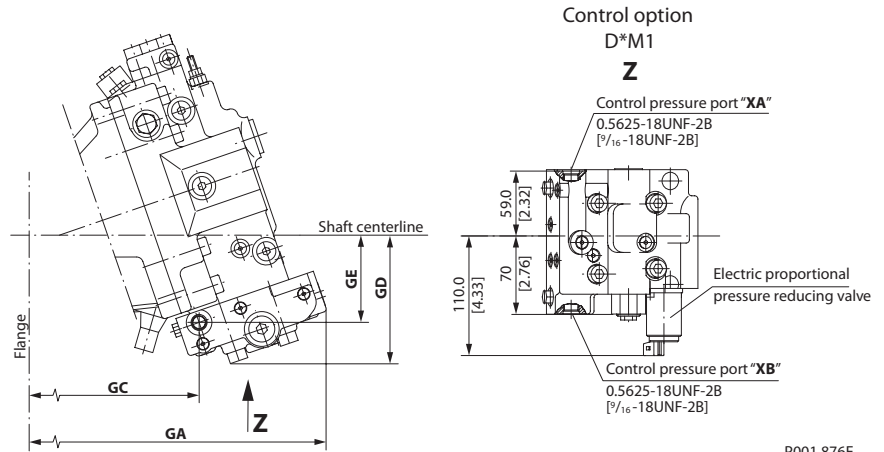

P001 876E

Control Options D7M1, D8M1 for 51							
Frame size		160			250		
Design		V	D	C	V	D	C
GA	mm [in]	407 [16.02]	375 [14.76]	270 [10.65]	459 [18.05]	—	
GC	mm [in]	283 [11.14]	251 [9.88]	146 [5.76]	334 [13.17]	—	
GD	mm [in]	133 [5.22]			141 [5.55]	—	
GE	mm [in]	92 [3.63]			101 [3.97]	—	

V = SAE-flange, D = DIN-flange, C = Cartridge-flange
 — = not available

Solenoid Connector

**AMP Junior Timer
 Two Pin Connector**
 (Supplied Connector)

Mating Connector
 No.: K19815
 Id.-No.: 508388

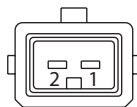

P001 751E

Shaft rotation is determined by viewing from shaft end.
 Ports with O-ring seal and inch threads shall be in accordance with ISO 11926/1.
 Splitte flange boss A and B per ISO 6162 is identical with high pressure series SAE J518 code 62 (6000 psi).
 Contact your Sauer-Danfoss representative for specific installation drawings.

**HYDRAULIC
 PROPORTIONAL
 CONTROL – OPTIONS**

mm
 [in]

HSA*

FOR 51

**FRAME SIZE
 060, 080, 110, 160, 250**

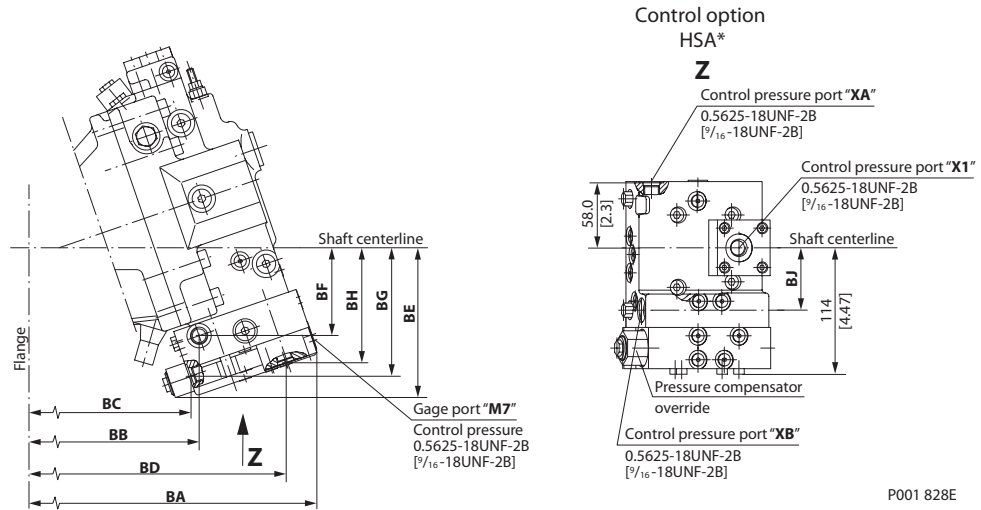

P001 828E

Control Option HSA* for 51																
Frame size	060			080			110			160			250			
Design	V	D	C	V	D	C	V	D	C	V	D	C	V	D	C	
BA	mm [in]	316 [12.45]	292 [11.49]	232 [9.13]	340 [13.37]	316 [12.34]	237 [9.34]	358 [14.10]	326 [12.84]	244 [9.60]	398 [15.66]	366 [14.40]	261 [10.29]	449 [17.70]	—	
BB	mm [in]	210 [8.26]	185 [7.29]	125 [4.94]	233 [9.18]	209 [8.23]	131 [5.15]	252 [9.90]	220 [8.65]	137 [5.40]	283 [11.14]	251 [9.88]	146 [5.76]	334 [13.17]	—	
BC	mm [in]	203 [8.00]	179 [7.04]	119 [4.69]	226 [8.88]	202 [7.94]	123 [4.85]	244 [9.61]	212 [8.35]	130 [5.11]	276 [10.85]	244 [9.59]	139 [5.48]	327 [12.88]	—	
BD	mm [in]	288 [11.35]	264 [10.38]	204 [8.03]	312 [12.27]	288 [11.32]	209 [8.24]	330 [12.99]	298 [11.74]	216 [8.49]	370 [14.56]	338 [13.30]	233 [9.18]	421 [16.59]	—	
BE	mm [in]	130 [5.12]			136 [5.35]			137 [5.41]			145 [5.72]			154 [6.06]		
BF	mm [in]	74 [2.91]			80 [3.15]			81 [3.20]			92 [3.63]			101 [3.97]		
BG	mm [in]	110 [4.33]			116 [4.58]			118 [4.64]			129 [5.06]			137 [5.41]		
BH	mm [in]	98 [3.87]			104 [4.10]			106 [4.16]			114 [4.47]			122 [4.81]		
BJ	mm [in]	56 [2.20]			56 [2.20]			56 [2.20]			57 [2.22]			57 [2.22]		

V = SAE-flange, D = DIN-flange, C = Cartridge-flange
 — = not available

Shaft rotation is determined by viewing from shaft end.
 Ports with O-ring seal and inch threads shall be in accordance with ISO 11926/1.
 Splitte flange boss A and B per ISO 6162 is identical with high pressure series SAE J518 code 62 (6000 psi).
 Contact your Sauer-Danfoss representative for specific installation drawings.

**HYDRAULIC
 PROPORTIONAL
 CONTROL – OPTION**

HZB1

FOR 51

**FRAME SIZE
 060, 080, 110, 160, 250**

mm
 [in]

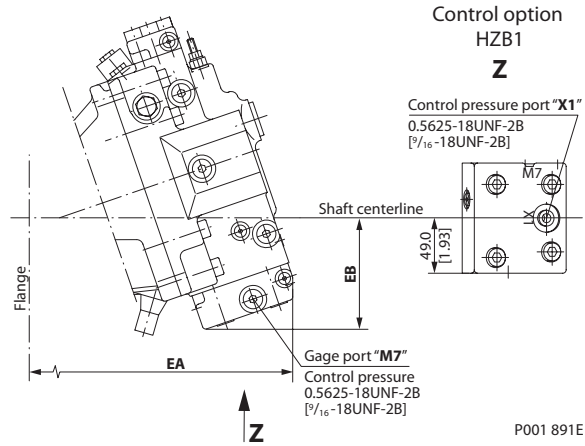

P001 891E

Control Option HZB1 for 51																
Frame size		060			080			110			160			250		
Design		V	D	C	V	D	C	V	D	C	V	D	C	V	D	C
EA	mm	294	270.0	209	318.0	294.0	215	337.0	305.0	221	376.0	345.0	239	429.0	—	
	[in]	[11.56]	[10.64]	[8.24]	[12.52]	[11.58]	[8.45]	[13.25]	[12.00]	[8.71]	[14.82]	[13.60]	[9.40]	[16.89]	—	
EB	mm	96			102			103			111			120		
	[in]	[3.77]			[4.00]			[4.06]			[4.37]			[4.71]		

V = SAE-flange, D = DIN-flange, C = Cartridge-flange
 — = not available

Shaft rotation is determined by viewing from shaft end.
 Ports with O-ring seal and inch threads shall be in accordance with ISO 11926/1.
 Splite flange boss A and B per ISO 6162 is identical with high pressure series SAE J518 code 62 (6000 psi).
 Contact your Sauer-Danfoss representative for specific installation drawings.

OUR PRODUCTS

Hydrostatic transmissions
Hydraulic power steering
Electro-hydraulic power steering
Electric power steering
Closed and open circuit axial piston pumps and motors
Electro motors
Gear pumps and motors
Bent axis motors
Radial piston motors
Orbital motors
Transit mixer drives
Planetary compact gears
Proportional valves
Directional spool valves
Cartridge valves
Hydraulic integrated circuits
Hydrostatic transaxles
Integrated systems
Fan drive systems
Electrohydraulic controls
Digital electronics and software
Battery powered inverter
Sensors

Sauer-Danfoss Hydraulic Power Systems – Market Leaders Worldwide

Sauer-Danfoss is a comprehensive supplier providing complete systems to the global mobile market.

Sauer-Danfoss serves markets such as agriculture, construction, road building, material handling, municipal, forestry, turf care, and many others.

We offer our customers optimum solutions for their needs and develop new products and systems in close cooperation and partnership with them.

Sauer-Danfoss specializes in integrating a full range of system components to provide vehicle designers with the most advanced total system design.

Sauer-Danfoss provides comprehensive worldwide service for its products through an extensive network of Authorized Service Centers strategically located in all parts of the world.

Sauer-Danfoss (US) Company
2800 East 13th Street
Ames, IA 50010, USA
Phone: +1 515 239-6000, Fax: +1 515 239-6618

Sauer-Danfoss (Neumünster) GmbH & Co. OHG
Postfach 2460, D-24531 Neumünster
Krokamp 35, D-24539 Neumünster, Germany
Phone: +49 4321 871-0, Fax: +49 4321 871-122

Sauer-Danfoss (Nordborg) A/S
DK-6430 Nordborg, Denmark
Phone: +45 7488 4444, Fax: +45 7488 4400

www.sauer-danfoss.com